

# HONDA VFR750F SERVICE MANUAL



## Table of Contents

[Contents](#)

[Symbols](#)

[General Information](#)

[General Safety](#)

[Carbon Monoxide](#)

[Gasoline](#)

[Coolant](#)

[Nitrogen Pressure](#)

[Battery Hydrogen Gas & Electrolyte](#)

[Model Identification](#)

Specifications

Torque Values

Tools

Lubrication & Seal Points

Cable & Harness Routing

Emission Control Systems

Source of Emissions

Crankcase Emission Control System

Exhaust Emission Control System

Evaporative Emission Control System

Noise emission control system

Emission Control Information Labels

Vehicle Emission Information Label

Vehicle Emission Control Information Update Label

Vacuum Hose Routing Diagram Label

Body Panels/Exhaust System/Sub Frame Service Information

Body Panels/Exhaust System/Sub Frame Troubleshooting

Abnormal engine vibration

Abnormal noise when riding

Seat removal

Seat installation

Rear Fairing

Middle Fairing

Lower Fairing

Lower Center Fairing

Trim Chip Removal/Installation

Upper Fairing

Requisite Service

Sub Frame/Rear fender

Fuel Tank

Maintenance

Service Access Guide

Maintenance Schedule

Air Cleaner

Sub air cleaner

Spark Plug

Valve Clearance

Shim selection

Carburetor Synchronization

Drive Chain

Drive Chain Slack Inspection

Headlight Aim

Side Stand

Lubrication System Service Information

Lubrication System Troubleshooting

Oil level low

High oil pressure

Lubrication System Diagram

Oil Pump Removal/Installation

Oil Pump Disassembly/Assembly

Oil Cooler Removal/Installation

Cooling System Service Information

Cooling System Troubleshooting

Engine temperature too high

Engine temperature too low

Cooling System Flow Pattern

Coolant Draining

Thermostat Removal/Installation

Radiator Removal/Installation  
Radiator Disassembly/Assembly  
Water Pump/Water Pipe Disassembly/Assembly  
Fuel System Service Information  
Fuel System Troubleshooting  
Engine won't start  
Lean mixture  
Rich mixture  
Air Cleaner Housing Removal/Installation  
Carburetor Removal/Installation  
Fuel Tank Disassembly/assembly  
Carburetor Separation/Combination  
Carburetor Tube Routing  
Carburetor Disassembly/Assembly  
Jet Needle Holder Removal/Installation  
Carburetor Body Cleaning  
Pilot Screw Adjustment  
Idle Drop Procedure  
High Altitude Adjustment  
Secondary Air Supply System  
Front Bank  
Pulse Secondary Air Injection (PAIR) Control Valve  
Rear Bank  
Engine Removal/Installation  
Engine Mounting Bolt Installation  
Rear Lower Engine Mounting Bolt  
Rear Upper Engine Mounting Bolt  
Cylinder Head/Valves Service Information  
Cylinder Head/Valves Troubleshooting

Low compression

Excessive smoke

Camshaft removal

Cylinder Head, Camshaft Idle Gear Case Removal/Installation

Cylinder Head Disassembly/Assembly

Camshaft Installation

Valve Cotters Removal/Installation

Camshaft Idle Gear Case Installation

Cylinder Head Bolt Installation

When Both Front and Rear Cylinder Camshafts Were removed

Clutch System Service Information

Clutch System Troubleshooting

Clutch lever soft or spongy

Clutch slips

Right Crankcase Cover Removal/Installation

Clutch Removal

Clutch Installation

Clutch Center Lock Nut Removal

Clutch Center Lock Nut Installation

Clutch Master Cylinder Disassembly/Assembly

Clutch Slave Cylinder Disassembly/Assembly

Gearshift Linkage Service Information

Gearshift Linkage Troubleshooting

Hard to Shift

Jumps out of gear

Drive Sprocket Cover Removal/installation

Gearshift Linkage Removal/Installation

Crankshaft/Piston/Transmission Service information

Crankshaft/Piston/Transmission Troubleshooting

Excessive noise

Transmission jumps out of gear

Crankcase Separation

Crankshaft/Connecting Rod Removal/Installation

Piston Disassembly/Assembly

Crankshaft Bearing Replacement

Main Journal Bearing Selection

Connecting Rod Bearing Selection

Connecting Rod Selection

Transmission Removal/Installation

Mainshaft Disassembly/Assembly

Countershaft Disassembly/Assembly

Crankcase installation

Front Wheel/Suspension/Steering Service information

Front Wheel/Suspension/Steering Troubleshooting

Hard steering

Soft suspension

Right Handlebar Removal/Installation

Left Handlebar Removal/installation

Front Wheel removal/Installation

Front Wheel Disassembly/Assembly

Fork Removal/Installation

Fork Disassembly

Steering Stem Removal/installation

Rear Wheel/Suspension

Rear Wheel Removal/Installation

Bearing Holder Removal/Installation

Driven Flange, Bearing Holder disassembly/assembly

Driven Flange Bearing Replacement

Axle Needle Bearing Replacement  
Shock Absorber Removal/Installation  
Lower Joint Removal/Installation  
Stopper Plate Removal/Installation  
Suspension Linkage Removal/Installation  
Suspension Linkage Disassembly/Assembly  
Cushion Rod Pivot Bearing Replacement  
Shock Arm Pivot Bearing Replacement  
Shock Link Bearing Replacement  
Swingarm Removal/Installation  
Swingarm Pivot Bolt Installation  
Swingarm Disassembly/Assembly  
Swingarm Pivot Bearing Replacement  
Right Pivot Bearing Removal  
Left Pivot Bearing Removal  
Left Pivot Bearing Installation  
Brakes Service information  
Brakes Troubleshooting  
Brake lever/pedal soft or spongy  
Brake lever/pedal hard  
Front Brake Pad Replacement  
Rear Brake Pad Replacement  
Front Master Cylinder Disassembly/Assembly  
Front Brake Caliper Removal/Installation  
Front Brake Caliper Disassembly/Assembly  
Rear Master Cylinder removal/installation  
Rear Master Cylinder disassembly/assembly  
Rear Brake Caliper Removal/Installation  
Rear Brake Caliper Disassembly/Assembly

Brake Pedal Removal/Installation

Charging System/Alternator

Charging System/Alternator System Location

Charging System/Alternator Circuit Diagram

Charging System/Alternator Troubleshooting

Battery undercharging

Battery Removal/Installation

Charging System Inspection

Leak Test

Charging Voltage inspection

Regulator/Rectifier

Wire Harness Inspection

Unit Inspection

Alternator Removal/Installation

Charging Coil Inspection

Ignition System Service information

Ignition System Location

Ignition System Circuit Diagram

Ignition System Troubleshooting

No spark at all plugs

No spark at either ignition group

No spark at one plug

Engine starts, but side stand switch does not function at all

Ignition System inspection

Ignition Coil

Ignition Pulse Generator

Ignition Timing

Ignition Coil Removal/Installation

Ignition Pulse Generator Removal/Installation

Electric Starter/Starter Clutch Service information

Electric Starter/Starter Clutch System Location

Electric Starter/Starter Clutch Circuit Diagram

Electric Starter/Starter Clutch Troubleshooting

Starter motor will not turn

Starter motor turns slowly

Starter motor turns, but engine does not turn

Starter relay switch "clicks", but engine does not turn over

Starter Motor Removal/Installation

Starter Motor Disassembly/Assembly

Starter clutch removal/installation

Starter clutch disassembly/assembly

Lights/Meters/Switches

Speedometer Does Not Operate

Headlight Bulb Replacement

Headlight Removal/Installation

Turn Signal Light

Taillight

Indicator Bulb Replacement

Combination Meter Removal/installation

Combination Meter Disassembly/Assembly

Tachometer Inspection

Ignition Switch Removal/Installation

Side Stand Switch

Fuel Level Sensor/Fuel Gauge

Low Fuel Indicator

Fuel Pump

Coolant Temperature Gauge

Thermosensor

[Oil Pressure Switch](#)

[Fan Motor Switch](#)

[Diode](#)

[Neutral Switch](#)

[Headlight Relay](#)

[Headlight does not shut off](#)

[High beam Relay](#)

[Wiring Diagram](#)

[Troubleshooting](#)

[Engine Does Not Start or is Hard to Start](#)

[Engine Lacks Power](#)

[Poor Performance at Low and Idle Speeds](#)

[Poor Performance at High Speed](#)

[Poor Handling](#)

[Index](#)

[Other ManualsLib Projects](#)

# **90-96 VFR 750F**

# **Service Manual**

**This manual is provided FREE of charge and should be distributed to as many VFR owners you know! I decided to scan this manual because, though most mechanics are very efficient, I found some to be incompetent, and wanted to be able to check their work. This manual cost me \$60, which I know some people can't afford. I think human lives are worth more than \$60. In my opinion, this manual should have come with the bike in the first place!!!**

This page is obviously not in the original service manual. All other pages are exactly as printed. Honda included several updated pages to this manual when I purchased it. These updates are included. If Honda has made any amendments/updates to this manual since November 1997. They are not included in this digitized manual.

# HONDA

## SERVICE MANUAL

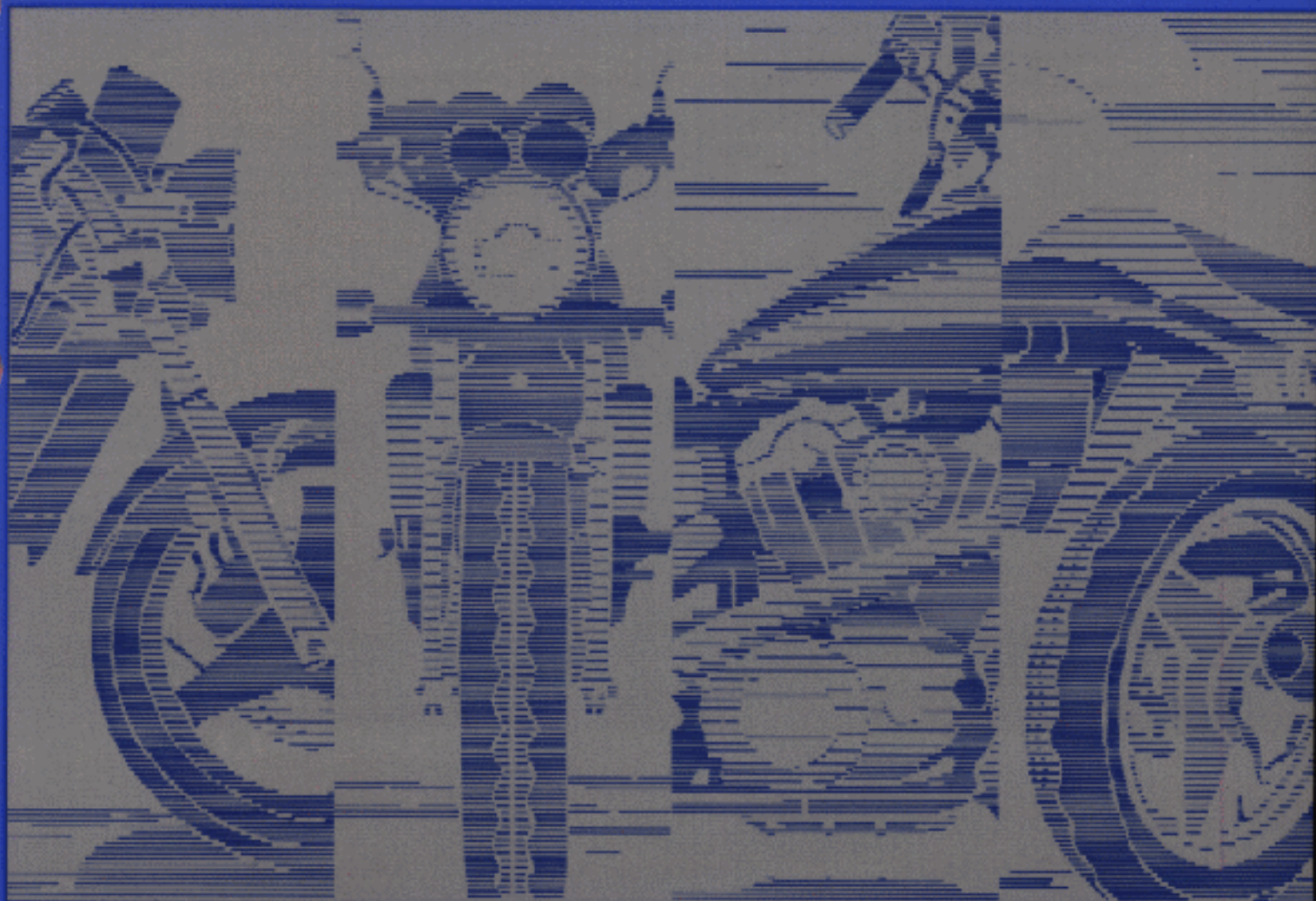

**90-96**  
**VFR750F**

61MT406

© HONDA MOTOR CO., LTD. 1994

## Important Safety Notice



**WARNING** Indicates a strong possibility of severe personal injury or death if instructions are not followed.

**CAUTION:** Indicates a possibility of equipment damage if instructions are not followed.

**NOTE:** Gives helpful information.

Detailed descriptions of standard workshop procedures, safety principles and service operations are not included. It is important to note that this manual contains *some* warnings and cautions against some specific service methods which could cause **PERSONAL INJURY** to service personnel or could damage a vehicle or render it unsafe. Please understand that those warnings could not cover all conceivable ways in which service, whether or not recommended by Honda, might be done or of the possibly hazardous consequences of each conceivable way, nor could Honda investigate all such ways. Anyone using service procedures or tools, whether or not recommended by Honda, *must satisfy himself thoroughly* that neither personal safety nor vehicle safety will be jeopardized by the service methods or tools selected.

# Introduction

This service manual describes the service procedures for the VFR750F.

This Model Specific Manual includes every service procedure that is of a specific nature to this particular model. Basic service procedures that are common to other Honda Motorcycles/Motor Scooters/ATVs are covered in the Common Service Manual. This Model Specific Service Manual should be used together with the Common Service Manual in order to provide complete service information on all aspects of this motorcycle.

Follow the Maintenance Schedule (Section 3) recommendations to ensure that the vehicle is in peak operating condition and the emission levels are within the standards set by the U.S. Environmental Protection Agency and the California Air Resources Board.

Performing the first scheduled maintenance is very important. It helps compensate for the initial wear that occurs during the break-in period.

Sections 1 through 3 apply to the whole motorcycle, while sections 4 through 19 describe parts of the motorcycle, grouped according to locations.

Find the section you want on this page, then turn to the table of contents on the first page of that section.

Most sections describe the service procedures through a system illustration. Refer to the next page for details on how to use this manual.

If you don't know the source of the trouble, go to section 20 TROUBLESHOOTING.

All information, illustrations, directions and specifications included in this publication are based on the latest product information available at the time of approval for printing. Honda Motor Co., Ltd. reserves the right to make changes at any time without notice and without incurring any obligation whatever. No part of this publication may be reproduced without written permission. This manual is written for persons who have acquired basic knowledge of maintenance on Honda motorcycles.

# Contents

	<b>General Information</b>	<b>1</b>
	<b>Body Panels/Exhaust System Sub Frame</b>	<b>2</b>
	<b>Maintenance</b>	<b>3</b>
<b>Engine and Drive Train</b>	<b>Lubrication</b>	<b>4</b>
	<b>Cooling System</b>	<b>5</b>
	<b>Fuel System</b>	<b>6</b>
	<b>Engine Removal/Installation</b>	<b>7</b>
	<b>Cylinder Head/Valves</b>	<b>8</b>
	<b>Clutch System</b>	<b>9</b>
	<b>Gearshift Linkage</b>	<b>10</b>
	<b>Crankshaft/Piston/Transmission</b>	<b>11</b>
<b>Chassis</b>	<b>Front Wheel/Suspension/Steering</b>	<b>12</b>
	<b>Rear Wheel/Suspension</b>	<b>13</b>
	<b>Brakes</b>	<b>14</b>
<b>Electrical</b>	<b>Charging System/Alternator</b>	<b>15</b>
	<b>Ignition System</b>	<b>16</b>
	<b>Electric Starter/Starter Clutch</b>	<b>17</b>
	<b>Lights/Meters/Switches</b>	<b>18</b>
	<b>Wiring Diagram</b>	<b>19</b>
	<b>Troubleshooting</b>	<b>20</b>
	<b>Index</b>	<b>21</b>

**HONDA MOTOR CO., LTD.  
SERVICE PUBLICATIONS OFFICE**

# How to Use This Manual

## Finding Information You Need

- This manual is divided into sections which cover each of the major components of the motorcycle.
- To quickly find the section you are interested in, the first page of each section is marked with a black tab that lines up with one of the thumb index tabs before this page.
- The first page of each section lists the table of contents within the section.
- Read the service information and troubleshooting related to the section before you begin working.
- An index of the entire book is provided in the last chapter to directly locate the information you need.

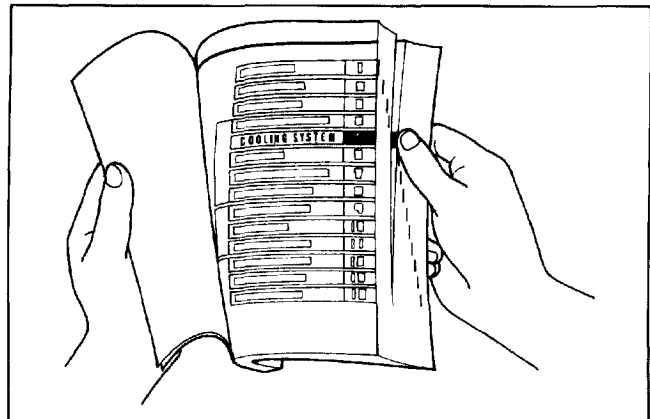

## Note on the Explanation Method of This Manual

- The removal and installation of parts are for the most part illustrated by large and clear illustrations that should provide the reader with visual aid in understanding the major point for servicing.
- The system illustrations are augmented by callouts whose numbers or letters indicate the order in which the parts should be removed or installed.
- The sequence of steps represented numerically are differentiated from the ones represented alphabetically to notify the reader that they must perform these steps separately.
- For example, if the steps prior and up to camshaft removal are performed with the engine installed, but the subsequent steps like cylinder head removal require engine removal, the callouts are grouped in numerical and alphabetical orders.
- The illustrations may contain symbol marks to indicate necessary service procedures and precautions that need to be taken. Refer to the next page for the meaning of each symbol mark.
- Also in the illustration is a chart that lists information such as the order in which the part is removed/installed, the name of the part, and some extra notes that may be needed.
- Step by step instructions are provided to supplement the illustrations when detailed explanation of the procedure is necessary or illustrations alone would not suffice.
- Service procedures required before or after the procedure described on that particular page, or inspection/adjustment procedures required following the installation of parts, are described under the title Requisite Service.
- Standard workshop procedures and knowledge covered in the Common Service Manual are abbreviated in this manual.

**Symbol mark**

**System illustration**

**Detailed description of the procedure**

**CYLINDER HEAD/CYLINDER/PISTON**

**CYLINDER HEAD REMOVAL/INSTALLATION**

REQUISITE SERVICE	PROCEDURE	REMARKS
Engine removal/installation (page 7-2)		
Camshaft removal/installation (page 8-2)		
REMOVAL ORDER	QTY	REMARKS
(11) Cylinder head special nut	12	Installation is in the reverse order of removal (installation page 8-5)
(12) Cylinder head mounting bolt	2	
(13) Cylinder head assembly	1	
(14) Gasket	1	Install with the UP mark facing up and rearward
(15) Dowel pin	2	
(16) Camshaft side gear case bolt	2	
(17) Camshaft side gear case dowel pin	2	Installation page 8-5
(18) Sealing washer	1	
(19) Camshaft side gear case	1	
(10) Carburetor/multiplier	1	At installation, align the insulator groove with the engine lug, with the UP mark facing towards (carburetor) side

**CYLINDER HEAD/CYLINDER/PISTON**

**CAMSHAFT IDLE GEAR CASE INSTALLATION**

Install the camshaft side gear case dowel pins properly.

**NOTE**

- Without the dowel pins installed properly, the camshaft side gear may not be able to be installed onto the crank shaft timing gear.

Install the camshaft side gear case onto the cylinder. Minus moving the idle gear tightly with the gear case head, the gear case should be lifted up slightly from the cylinder.

Install a new sealing washer and mounting bolts. Tighten bolts in a gradual, as shown.

**CYLINDER HEAD NUT/BOLT INSTALLATION**

Install the cylinder head special nuts as shown. Do not tighten them yet.

Install the cylinder head mounting bolts. Tighten the special nuts and mounting bolts in a gradual, crosswise pattern.

**TORQUE**

Special nut: 30 Nm (3.0 kg-m, 22 ft-lb)  
 Mounting bolt: 12 Nm (1.2 kg-m, 9 ft-lb)

**Part name**

**Number of parts**

**Extra notes or precaution related to the service procedure**

**Step sequence (numerals or alphabets)**

**Symbol mark**















**System illustration**

**Detailed description of the procedure**

B-4
B-5

# Symbols

The symbols used throughout this manual show specific service procedures. If supplementary information is required pertaining to these symbols, it would be explained specifically in the text without the use of the symbols.

	<p>Replace the part(s) with new one(s) before assembly.</p>
	<p>Use special tool</p>
	<p>Use optional tool. Use the same procedure you use to order parts.</p>
 <p>10 (1.0, 7.2)</p>	<p>Torque specification.    10 N·m (1.0 kg-m, 7.2 ft-lb)</p>
	<p>Use recommended engine oil, unless otherwise specified.</p>
	<p>Use molybdenum oil solution (mixture of the engine oil and molybdenum grease in a ratio of 1 : 1).</p>
	<p>Use multi-purpose grease (Lithium based multi-purpose grease NLGI #2 or equivalent)</p>
	<p>Use molybdenum disulfide grease (containing more than 3% molybdenum disulfide, NLGI #2 or equivalent)          Example: Molykote® BR-2 plus manufactured by Dow Corning, U.S.A.          Multi-purpose M-2 manufactured by Mitsubishi Oil Japan</p>
	<p>Use molybdenum disulfide paste (containing more than 40% molybdenum disulfide, NLGI #2 or equivalent)          Example: Molykote® G-n Paste manufactured by Dow Corning, U.S.A.          Honda Moly 60 (U.S.A. only)          Rocol ASP manufactured by Rocol Limited, U.K.          Rocol Paste manufactured by Sumico Lubricant, Japan</p>
	<p>Use silicone grease</p>
	<p>Apply a locking agent. Use a middle strength locking agent unless otherwise specified.</p>
	<p>Apply sealant</p>
	<p>Use brake fluid, DOT 3 or DOT 4. Use the recommended brake fluid, unless otherwise specified.</p>
	<p>Use Fork or Suspension Fluid.</p>



# 1. General Information

1

General Safety	1-1	Lubrication & Seal Points	1-25
Model Identification	1-3	Cable & Harness Routing	1-29
Specifications	1-5	Emission Control Systems	1-42
Torque Values	1-16	Emission Control Information Labels (U.S.A. only)	1-44
Tools	1-23		

## General Safety

### Carbon Monoxide

If the engine must be running to do some work, make sure the area is well ventilated. Never run the engine in an enclosed area.

#### ▲ WARNING

- The exhaust contains poisonous carbon monoxide gas that can cause loss of consciousness and may lead to death.

Run the engine in an open area or with an exhaust evacuation system in an enclosed area.

### Gasoline

Work in a well ventilated area. Keep cigarettes, flames or sparks away from the work area or where gasoline is stored.

#### ▲ WARNING

- Gasoline is extremely flammable and is explosive under certain conditions. KEEP OUT OF REACH OF CHILDREN.

### Hot Components

#### ▲ WARNING

- Engine and exhaust system parts become very hot and remain hot for some time after the engine is run. Wear insulated gloves or wait until the engine and exhaust system have cooled before handling these parts.

### Used Engine/Transmission Oil

#### ▲ WARNING

- Used engine oil (or transmission oil in two-strokes) may cause skin cancer if repeatedly left in contact with the skin for prolonged periods. Although this is unlikely unless you handle used oil on a daily basis, it is still advisable to thoroughly wash your hands with soap and water as soon as possible after handling used oil. KEEP OUT OF REACH OF CHILDREN.

### Brake Dust

Never use an air hose or dry brush to clean brake assemblies. Use an OSHA-approved vacuum cleaner or alternate method approved by OSHA, designed to minimize the hazard caused by airborne asbestos fibers.

#### ▲ WARNING

- Inhaled asbestos fibers have been found to cause respiratory disease and cancer.

### Brake Fluid

#### CAUTION

- Spilling fluid on painted, plastic or rubber parts will damage them. Place a clean shop towel over these parts whenever the system is serviced. KEEP OUT OF REACH OF CHILDREN.

## General Information

### Coolant

Under some conditions, the ethylene glycol in engine coolant is combustible and its flame is not visible. If the ethylene glycol does ignite, you will not see any flame, but you can be burned.

#### ⚠ WARNING

- **Avoid spilling engine coolant on the exhaust system or engine parts. They may be hot enough to cause the coolant to ignite and burn without a visible flame.**
- **Coolant (ethylene glycol) can cause some skin irritation and is poisonous if swallowed. KEEP OUT OF REACH OF CHILDREN.**
- **Do not remove the radiator cap when the engine is hot. The coolant is under pressure and could scald you.**
- **Keep hands and clothing away from the cooling fan, as it starts automatically.**

If it contacts your skin, wash the affected areas immediately with soap and water. If it contacts your eyes, flush them thoroughly with fresh water and get immediate medical attention. If it is swallowed, the victim must be forced to vomit then rinse mouth and throat with fresh water before obtaining medical attention. Because of these dangers, always store coolant in a safe place, away from the reach of children.

### Nitrogen Pressure

For shock absorbers with a gas-filled reservoir:

#### ⚠ WARNING

- **The shock absorber contains nitrogen under high pressure. Allowing fire or heat near the shock absorber could lead to an explosion that could result in serious injury.**
- **Failure to release the pressure from a shock absorber before disposing of it may lead to a possible explosion and serious injury if it is heated or pierced.**

### Battery Hydrogen Gas & Electrolyte

#### ⚠ WARNING

- **The battery gives off explosive gases; keep sparks, flames and cigarettes away. Provide adequate ventilation when charging.**
- **The battery contains sulfuric acid (electrolyte). Contact with skin or eyes may cause severe burns. Wear protective clothing and a face shield.**
  - **If electrolyte gets on your skin, flush with water.**
  - **If electrolyte gets in your eyes, flush with water for at least 15 minutes and call a physician.**
- **Electrolyte is poisonous.**
  - **If swallowed, drink large quantities of water or milk and follow with milk of magnesia or vegetable oil and call a physician. KEEP OUT OF REACH OF CHILDREN.**

# Model Identification

'90 Shown, '91, '92 and '93 Similar:

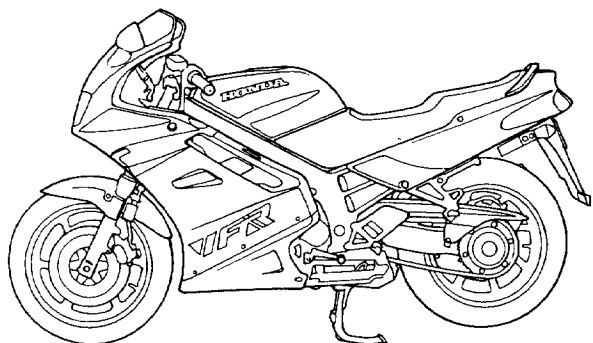

After '93:

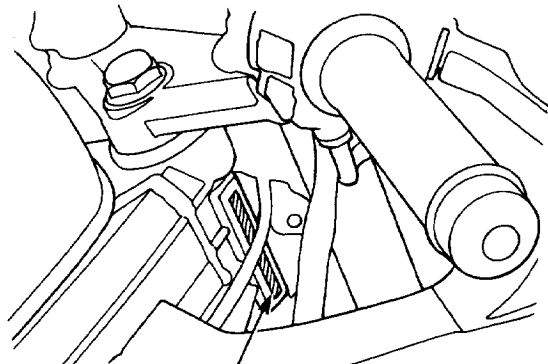
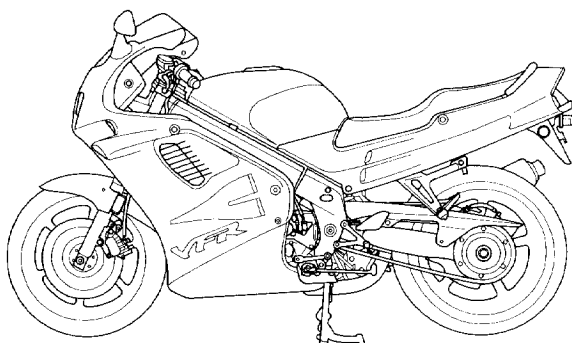

(1) FRAME SERIAL NUMBER

(2) ENGINE SERIAL NUMBER

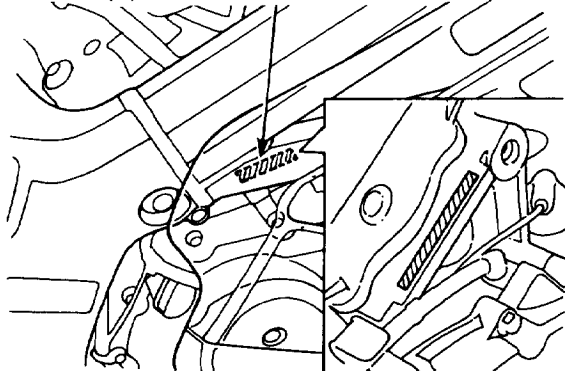

The frame serial number is stamped on the right side of the steering head.

The engine serial number is stamped on the right side of the crankcase.

'90-'93:

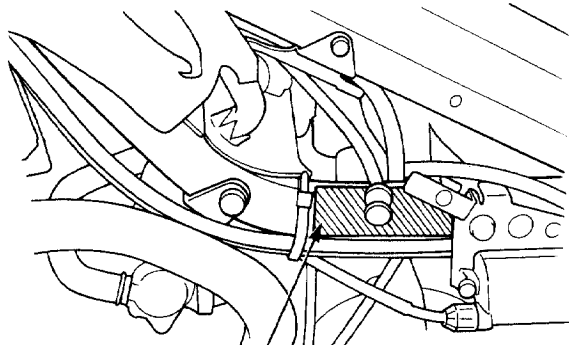

(3) VEHICLE IDENTIFICATION NUMBER

After '93:

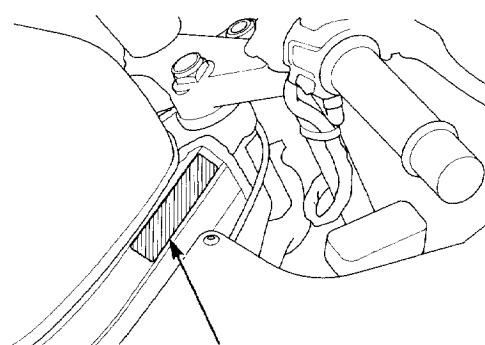

(3) VEHICLE IDENTIFICATION NUMBER

The Vehicle Identification Number (VIN) is located on the left side of the frame down tube.

The Vehicle Identification Number (VIN) is located on the right side of the main frame.

# General Information

'90-'93:

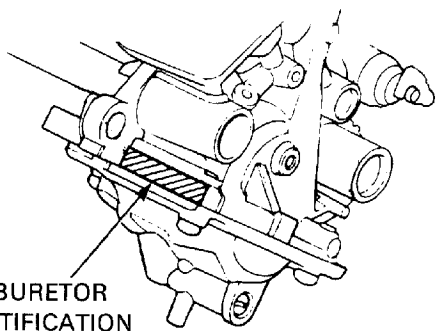

(4) CARBURETOR IDENTIFICATION NUMBER

After '93:

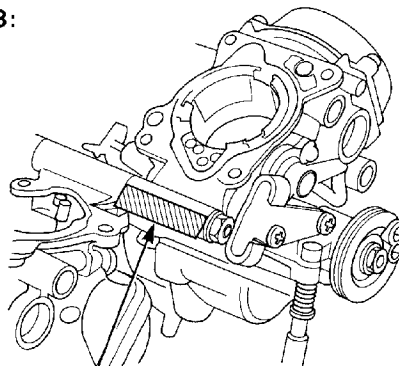

(4) CARBURETOR IDENTIFICATION NUMBER

The carburetor identification number is stamped on the intake side of each carburetor body.

'90-'93:

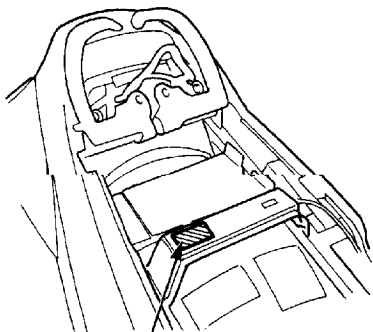

(5) COLOR CODE LABEL

The color code label is attached on the upper rear sub frame tube cross member under the seat. When ordering a color coded part, always specify its designated color code.

After '93:

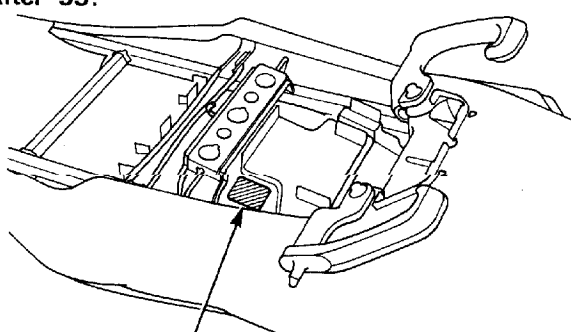

(5) COLOR CODE LABEL

The color code label is attached on the rear fender under the seat. When ordering a color coded part, always specify its designated color code.

## Specifications

General		Item	Specifications
Dimensions	Overall length	'90-'93:	2,180 mm (85.8 in)
		After '93:	2,125 mm (83.7 in)
	Overall width	'90-'93:	700 mm (27.6 in)
		After '93:	720 mm (28.3 in)
	Overall height		1,185mm (46.7 in)
	Wheelbase		1,470 mm (57.9 in)
	Seat height		800 mm (31.5 in)
	Footpeg height		350 mm (13.8 in)
	Ground clearance		130 mm (5.1 in)
	Dry weight	'90-'93:	216 kg (476 lbs)
		After '93: (49 state type)	211 kg (465 lbs)
		(California type)	212 kg (467 lbs)
		(Canada type)	210 kg (463 lbs)
	Curb weight	'90-'93:	240 kg (529 lbs)
		After '93: (49 state type)	237 kg (523 lbs)
		(California type)	238 kg (525 lbs)
		(Canada type)	236kg (520 lbs)
Maximum weight capacity	'90-'93:	189 kg (417 lbs)	
	After '93:		
	(49 state/California type)	175 kg (386 lbs)	
	(Canada type)	179 kg (395 lbs)	
Frame	Frame type		Diamond
	Front suspension		Telescopic fork
	Front wheel travel	'90-'93:	140 mm (5.5 in)
		After '93:	130 mm (5.1 in)
	Rear suspension		Swingarm, Pro-link
	Rear wheel travel		130 mm (5.1 in)
	Rear damper		Gas-filled damper
	Front tire size		120/70 VR17-V250, 120/70 ZR17
	Rear tire size		170/60 VR17-V250, 170/60 ZR17
	Tire brand		
	(Bridgestone) FR/RR	'90:	CYROX-19F/CYROX-16F
		After '93:	BT54F RADIAL G/BT54R RADIAL G
	(Dunlop) FR/RR	'91-'93:	K510FC/K510C
		After '93:	D202FN/D202J
	(Michelin) FR/RR	'90:	A59X (COO)/M59X (AOO)
		After '93:	A89X/M89X
	Front brake		Hydraulic disc brake
Rear brake		Hydraulic disc brake	
Caster angle		26°	
Trail length	'90-'93:	100 mm (3.9 in)	
	After '93:	99 mm (3.9 in)	
Fuel tank capacity	'90-'93:	19 lit. (5.0 US gal, 4.2 Imp gal)	
	After '93:	21 lit. (5.5 US gal, 4.6 Imp gal)	
Fuel tank reserve capacity		3.5 lit. (0.92 US gal, 0.77 Imp gal)	

**General Information**

**General (cont'd)**

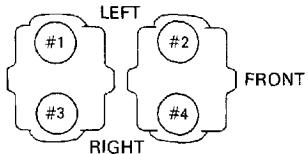
	Item	Specifications
Engine	Bore and stroke Displacement Compression ratio Valve train Intake valve opens at 1mm lift '90-'93: After '93: (49 state/Canada) (California) Intake valve closes at 1mm lift '90-'93: After '93: (49 state/Canada) (California) Exhaust valve opens at 1mm lift '90-'93: After '93: (49 state/Canada) (California) Exhaust valve closes at 1mm lift '90-'93: After '93: (49 state/Canada) (California) Lubrication system Oil pump type Cooling system Air filtration Crankshaft type Engine weight (dry)      '90-'93 After '93: Firing order Cylinder arrangement Cylinder number	70.0 x 48.6 mm (2.76 x 1.91 in) 748 cm <sup>3</sup> (45.6 cu-in) 11.0 : 1 Gear driven DOHC, 4 valves per cylinder 15° BTDC 15° BTDC -5° BTDC 35° ABDC 37° ABDC 35° ABDC 40° BBDC 35° BBDC 45° BBDC 10° ATDC 10° ATDC -5° ATDC Forced pressure and wet type Trochoid Liquid cooling system with cooling fan Paper filter Unit-type, 4 main journals 79 kg (174 lbs) 76.5 kg (169 lbs) # 1-180° - # 3-270° - # 2-180° - # 4-90° - # 1 4 cylinders, 90°V 
Carburetor	Carburetor type Throttle bore      '90-'93: After '93:	Constant Venturi 36 mm (1.4 in) 34 mm (1.3 in)
Drive train	Clutch system Clutch operation system Transmission Primary reduction Secondary reduction Third reduction Final reduction Gear ratio 1st Gear ratio 2nd Gear ratio 3rd Gear ratio 4th Gear ratio 5th Gear ratio 6th Gear ratio reverse Gearshift pattern	Wet, multi-plate Hydraulic 6-speeds, constant-mesh 1.939 (64/33) _____ 2.6875 (43/16) 2.8461 (37/13) 2.0625 (33/16) 1.6315 (31/19) 1.3333 (28/21) 1.1538 (30/26) 1.0357 (29/28) _____ Left foot operated return system 1-N-2-3-4-5-6
Electrical	Ignition system Starting system Charging system Regulator/rectifier Lighting system AC regulator type	Full transistor ignition Electric starter motor Triple phase output alternator SCR shorted/triple phase, full-wave rectification Battery _____

Lubrication		Standard	Service limit
Engine oil capacity at draining		2.9 l (3.1 US qt, 2.6 Imp qt)	_____
at disassembly	'90-'93:	4.0 l (4.2 US qt, 3.5 Imp qt)	_____
	After '93:	3.8 l (4.0 US qt, 3.3 Imp qt)	_____
at oil filter change		3.1 l (3.3 US qt, 2.7 Imp qt)	_____
Recommended engine oil		Use Honda 4-stroke oil an equivalent. API service classification SF or SG.	_____
	<p>OIL VISCOSITIES</p> <p>The viscosities shown in the chart may be used when the average temperature in your riding area is within the indicated range.</p>		
Oil pressure at oil pressure switch		490-588 kPa (5.0-6.0 kg/cm <sup>2</sup> , 71.1-85.3 psi)	_____
Oil pump rotor tip clearance ①		0.10 (0.004)	0.15 (0.006)
body clearance ②		0.15-0.22 (0.006-0.009)	0.35 (0.014)
end clearance ③		0.02-0.07 (0.001-0.003)	0.10 (0.004)

Fuel system		Standard	Service limit
Carburetor identification number			
(49 state type)	'90-'91:	VDJBA	_____
	'92-'93:	VDJJA	_____
	After '93:	VP34A	_____
(California type)	'90-'91:	VDJCA	_____
	'92-'93:	VDJKA	_____
	After '93:	VP33A	_____
(Canada type)	'90-'91:	VDJ1A	_____
	'92-'93:	VDJ5A	_____
	After '93:	VP35A	_____
Main jet	'90-'93:	# 130	_____
	After '93:	# 125 (49 state/Canada type)	_____
		Front: # 128/	_____
		Rear: # 125 (California type)	_____
	(High altitude)	_____	_____
	(2,3)	_____	_____
	(1,4)	_____	_____
Slow jet	(49 state/Canada type)	# 40	_____
	(California type) '90-'93:	# 38	_____
	After '93:	# 40	_____
Jet needle position		_____	_____
Pilot screw initial opening		See page 6-22	_____
Pilot screw high altitude adjustment		See page 6-24	_____
Pilot screw final opening		See page 6-22	_____
Air screw initial opening		_____	_____
Air screw high altitude adjustment		_____	_____
Float level	'90-'93:	9.0 (0.35)	_____
	After '93:	13.7 (0.54)	_____
Carburetor vacuum difference		Within 20 mmHg (0.8 inHg)	40 mmHg (1.6 inHg)
Base carburetor (For carburetor synchronization)			
	'90-'93:	No.2 carburetor	_____
	After '93:	No.1 carburetor	_____
Idle speed	(49 state type) '90-'93:	1,000 ± 100 rpm	_____
	After '93:	1,100 ± 100 rpm	_____
	(California type)	1,200 ± 100 rpm	_____
	(Canada type)	1,000 ± 100 rpm	_____
Throttle grip free play		2-6 (0.08-0.24)	_____
Accelerator pump clearance		_____	_____
Pulse secondary air injection (PAIR) control valve vacuum pressure (U.S.A. only)		360 mmHg (14.2 inHg)	_____

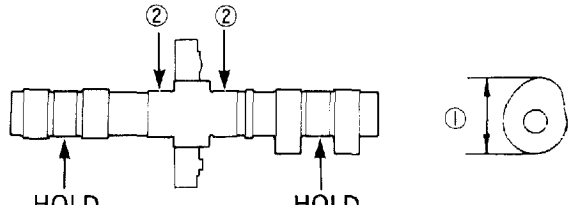
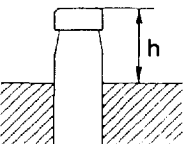
Cylinder head	Item	Standard	Service limit
	Cylinder compression	1.373 kPa (14.0 kg/cm <sup>2</sup> , 199 psi)/400 rpm	—
	Cylinder compression difference	Within 30 mmHg (1.2 inHg) of each other	—
	Valve clearance IN (cold)	0.13–0.19 (0.005–0.007)	—
	EX	0.22–0.28 (0.009–0.011)	—
	Cylinder head warpage	—	0.1 (0.004)
	Cam lobe height ① IN (49 state/Canada type) (California type)	36.280–36.440 (1.4283–1.4346)	36.25 (1.427)
	EX (49 state/Canada type) '90–'93:	36.370–36.530 (1.4319–1.4382)	36.34 (1.431)
	After '93:	36.070–36.230 (1.4201–1.4264)	36.04 (1.419)
	(California type) '90–'93:	35.270–35.430 (1.3886–1.3949)	35.24 (1.3874)
	After '93:	35.470–35.630 (1.3965–1.4028)	35.44 (1.3953)
	Camshaft runout ②	—	0.05 (0.002)
	Camshaft oil clearance	0.020–0.062 (0.0008–0.0024)	0.10 (0.004)
			
	Camshaft journal O.D.	24.949–24.970 (0.9822–0.9831)	24.94 (0.982)
	Camshaft holder – Cylinder head I.D.	25.000–25.021 (0.9843–0.9851)	—
	Valve stem O.D. IN	4.475–4.490 (0.1762–0.1767)	4.465 (0.1758)
	EX	4.465–4.480 (0.1758–0.1764)	4.455 (0.1754)
	Valve guide I.D. IN	4.500–4.512 (0.1772–0.1776)	4.562 (0.1796)
	EX	4.500–4.512 (0.1772–0.1776)	4.612 (0.1816)
	Stem-to-guide clearance IN	0.010–0.037 (0.0004–0.0015)	0.07 (0.0028)
	EX	0.020–0.047 (0.0008–0.0019)	0.10 (0.0039)
	Valve guide projection above cylinder head (h) IN	15.30–15.50 (0.602–0.610)	—
	EX	15.30–15.50 (0.602–0.610)	—
	 <p>Before guide installation:</p> <ol style="list-style-type: none"> <li>1. Chill the valve guides in the freezer section of a refrigerator for about an hour.</li> <li>2. Heat the cylinder head to 100–150 °C (212–300°F).</li> </ol>		
	Valve seat width IN	1.0 (0.04)	1.5 (0.06)
	EX	1.0 (0.04)	1.5 (0.06)
	Valve spring free length Inner	34.2 (1.35)	32.5 (1.28)
	Outer	38.1 (1.50)	36.2 (1.43)
	inner IN	—	—
	inner EX	—	—
	outer IN	—	—
	outer EX	—	—
	Rocker arm I.D. IN	—	—
	EX	—	—
	Rocker arm shaft O.D. IN	—	—
	EX	—	—
	Rocker arm-to-rocker arm shaft clearance	—	—
	Valve lifter O.D.	25.978–25.993 (1.0228–1.0233)	25.968 (1.0224)
	Valve lifter bore I.D.	26.010–26.026 (1.0240–1.0246)	26.04 (1.025)
	Hydraulic lash adjuster assist spring free length	—	—
	Hydraulic lash adjuster compression stroke with kerosene	—	—

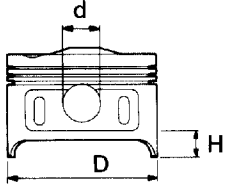
Cylinder/piston	Item	Standard	Service limit
	Cylinder I.D.	70.000–70.015 (2.755–2.756)	70.10 (2.759)
	Cylinder out of round	—	0.10 (0.004)
	Cylinder taper	—	0.10 (0.004)
	Cylinder warpage	—	0.10 (0.004)
	Piston mark direction	With "IN" mark facing to the intake side	—
	Piston O.D. (D)	69.970–69.990 (2.755–2.756)	69.85 (2.750)
	Piston O.D. measurement point (H)	10 (0.4)	—
	Piston pin hole I.D. (d)	17.002–17.008 (0.6694–0.6696)	17.02 (0.670)
			
	Cylinder-to-piston clearance	—	—
	Piston pin O.D.	16.994–17.000 (0.6691–0.6693)	16.98 (0.669)
	Piston-to-piston pin clearance	0.002–0.014 (0.0001–0.0005)	—
	Connecting rod-to-piston pin clearance	0.016–0.040 (0.0006–0.0020)	—
	Top ring-to-ring groove clearance	0.015–0.050 (0.0006–0.0019)	0.10 (0.04)
	Second ring-to-ring groove clearance	0.015–0.045 (0.0006–0.0018)	0.10 (0.004)
	Top ring end gap	0.20–0.35 (0.008–0.014)	0.5 (0.02)
	Second ring end gap	0.35–0.50 (0.014–0.020)	0.7 (0.03)
	Oil ring (side rail) end gap	0.20–0.80 (0.008–0.031)	1.00 (0.039)
	Top ring mark	Install with the marked side up	—
	Second ring mark	Install with the marked side up	—

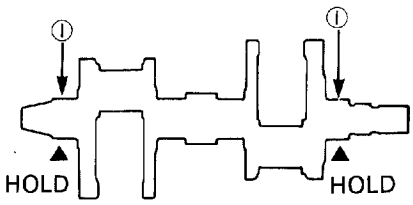
Crankshaft	Item	Standard	Service limit
	Connecting and small end I.D.	17.016–17.034 (0.6699–0.6706)	17.04 (0.671)
	Connecting rod big end side clearance radial clearance	0.10–0.30 (0.004–0.012)	0.40 (0.016)
	Crankshaft runout ①	—	0.05 (0.002)
			
	Crankpin oil clearance	0.030–0.052 (0.0012–0.0020)	0.08 (0.003)
	Connecting rod bearing selection	See page 11-9	—
	Main journal oil clearance	'90-'93: 0.023–0.045 (0.0009–0.0018) After '93: 0.019–0.037 (0.0007–0.0015)	0.06 (0.002) 0.05 (0.002)
	Main journal bearing selection	See page 11-8	—

Starter system	Item	Standard	Service limit
	Starter motor brush length	12.0–13.0 (0.47–0.51)	6.5 (0.26)
	Starter clutch driven gear O.D.	47.175–47.200 (1.8573–1.8583)	47.16 (1.857)
	Kickstarter pinion gear I.D.	—	—
	Kickstarter spindle O.D.	—	—
	Kickstarter idle gear I.D.	—	—
	Countershaft O.D. at kickstarter idle gear	—	—
	Kickstater idle gear bushing O.D. I.D.	—	—

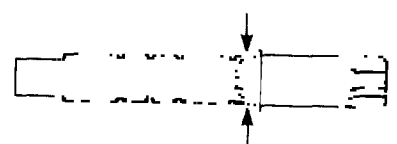
Transmission	Item	Standard	Service limit
Transmission gear I.D.	M5	28.000-28.021 (1.1024-1.1032)	28.04 (1.104)
	M6	28.000-28.021 (1.1024-1.1032)	28.04 (1.104)
	C2	31.000-31.016 (1.2205-1.2211)	31.04 (1.222)
	C3	31.000-31.016 (1.2205-1.2211)	31.04 (1.222)
	C4	31.000-31.016 (1.2205-1.2211)	31.04 (1.222)
Transmission gear bushing O.D.	M5	27.959-27.980 (1.1007-1.1016)	27.94 (1.010)
	M6	27.959-27.980 (1.1007-1.1016)	27.94 (1.010)
	C2	30.970-30.995 (1.2193-1.2203)	30.95 (1.219)
	C3	30.950-30.975 (1.2185-1.2195)	30.93 (1.218)
	C4	30.950-30.975 (1.2185-1.2195)	30.93 (1.218)
Transmission gear bushing I.D.	M5	24.985-25.006 (0.9834-0.9845)	27.94 (1.010)
	C2	28.000-28.021 (1.1024-1.1032)	28.04 (1.104)
	C3	27.995-28.016 (1.1022-1.1029)	28.04 (1.104)
	C4		
Gear-to-bushing clearance	at M5 gear	0.020-0.062 (0.0008-0.0024)	—
	at M6 gear	0.020-0.062 (0.0008-0.0024)	—
	at C2 gear	0.005-0.046 (0.0002-0.0018)	—
	at C3 gear	0.025-0.066 (0.0001-0.0026)	—
	at C4 gear	0.025-0.066 (0.0001-0.0026)	—
Mainshaft O.D. at M5 gear bushing	24.959-24.980 (0.9826-0.9835)	24.95 (0.982)	
			
Countershaft O.D. at C2 gear bushing	27.967-27.980 (1.1011-1.1016)	27.96 (1.101)	
			
Gear-to-shaft clearance	—	—	
Gear bushing-to-shaft clearance	at M5 gear	0.005-0.047 (0.0002-0.0019)	—
	at C2 gear	0.020-0.054 (0.0008-0.0021)	—
	at C3 gear	0.015-0.049 (0.0006-0.0019)	—
	at C4 gear	0.015-0.049 (0.0006-0.0019)	—
Shift fork claw thickness	L	6.43-6.50 (0.253-0.256)	6.40 (0.252)
	C	6.43-6.50 (0.253-0.256)	6.40 (0.252)
	R	6.43-6.50 (0.253-0.256)	6.40 (0.252)
Shift fork I.D.	L	14.016-14.034 (0.5518-0.5525)	14.043 (0.5529)
	C	14.016-14.034 (0.5518-0.5525)	14.043 (0.5529)
	R	14.016-14.034 (0.5518-0.5525)	14.043 (0.5529)
Shift fork shaft O.D.	13.973-13.984 (0.5501-0.5506)	13.965 (0.5498)	

Unit: mm (in)

Clutch system	Item	Standard	Service limit
	Clutch lever free play	10–20 (0.4–0.8)	—
	Recommended clutch fluid	DOT4	—
	Clutch master cylinder I.D.	14.000–14.043 (0.5512–0.5529)	14.06 (0.553)
	Clutch master piston O.D.	13.957–13.984 (0.5495–0.5506)	13.94 (0.549)
	Clutch slave cylinder I.D.	35.700–35.762 (1.4055–1.4079)	35.78 (1.409)
	Clutch slave cylinder piston O.D.	35.650–35.675 (1.4035–1.4045)	35.63 (1.403)
	Clutch outer guide I.D.	24.995–25.012 (0.9841–0.9847)	25.08 (0.987)
	Clutch spring free length	44.4 (1.75)	41.2 (1.62)
	Clutch disc thickness A	2.92–3.08 (0.115–0.121)	2.5 (0.10)
	B (Judder spring side)	2.92–3.08 (0.115–0.121)	2.5 (0.10)
	C	—	—
	Clutch plate warpage	—	—
	Centrifugal clutch drum I.D.	—	—
	bushing O.D.	—	—
	Centrifugal clutch center guide I.D.	—	—
	O.D.	—	—
	Centrifugal clutch center guide collar height	—	—
	Centrifugal clutch weight lining thickness	—	—
	Centrifugal clutch spring free length	—	—
	Clutch lining thickness	—	—
	Crankshaft O.D. at clutch center	—	—

Cooling system		
Cooling capacity (Radiator and engine)	2.3 ℓ (0.61 US gal, 0.51 Imp gal)	—
(Reserve tank)	0.3 ℓ (0.08 US gal, 0.07 Imp gal)	—
Radiator cap relief pressure	93–123 kPa (0.95–1.25 kg/cm <sup>2</sup> , 14–18 psi)	—
Thermostat begins to open	80–84°C (176–183°F)	—
Thermostat fully open	95°C (203°F)	—
Thermostat valve lift	8.0 (0.315) min.	—

Drive train		
Recommended final drive oil	—	—
Final drive gear oil capacity at disassembly	—	—
at draining	—	—
Final drive gear backlash	—	—
Ring gear-to stop pin clearance (A)	—	—
Stop pin shim	—	—
Ring gear spacer	—	—
Pinion spacer	—	—
Output gear backlash	—	—
Output gear I.D.	—	—
Output gear bushing O.D.	—	—
I.D.	—	—
Output drive shaft O.D.	—	—
Output gear damper spring free length	—	—
Output shaft adjustment shim	—	—
Countershaft drive shaft adjustment shim	—	—

Wheels/tires		Standard	Service limit
Item			
Minimum tire tread depth (FR)		_____	1.5 (0.06)
(RR)		_____	2.0 (0.08)
Cold tire pressure Rider only (FR)		250 kPa (2.50 kg/cm <sup>2</sup> , 36 psi)	_____
Rider only (RR)		290 kPa (2.90 kg/cm <sup>2</sup> , 42 psi)	_____
Rider and passenger (FR)		250 kPa (2.50 kg/cm <sup>2</sup> , 36 psi)	_____
Rider and passenger (RR)		290 kPa (2.90 kg/cm <sup>2</sup> , 42 psi)	_____
Front and rear axle runout		_____	0.2 (0.01)
Front and rear wheel runout (Radial)		_____	2.0 (0.08)
(Axial)		_____	2.0 (0.08)
Front wheel hub-to-rim distance		_____	_____
Front wheel hub standard surface		_____	_____
Rear wheel hub-to-rim distance		_____	_____
Rear wheel hub standard surface		_____	_____
Wheel balance weight (FR/RR)		_____	60 g (2.1 oz)
Drive chain slack		15-25 (0.6-1.0)	40 (1.6)
Drive chain size/link (DID)	'90-'93:	DID50VA6-122	_____
	After '93:	DID50V4-122	_____
(RK)	'90-'93:	RK50HFO-122	_____
	After '93:	RK50MFOZ1-122	_____

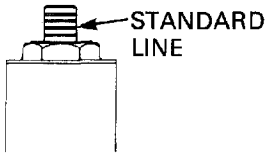
Front suspension		Standard	Service limit
Front spring free length	'90-'91:	413.6 (16.28)	405.3 (15.96)
	'92-'93:	427.1 (16.81)	418.5 (16.48)
	After '93:	340.2 (13.39)	330.0 (13.0)
Front spring free length A		_____	_____
B		_____	_____
Fork spring direction		Tightly wound coil end facing down	_____
Fork tube runout		_____	0.2 (0.01)
Recommended fork oil		Pro Honda Suspension Fluid SS-7	_____
Fork oil level (49 state/California type)	'90-'91:	175 (6.89)	_____
	'92-'93:	178 (7.01)	_____
	After '93:	177 (6.97)	_____
(Canada type)	'90-'91:	187 (7.36)	_____
	'92-'93:	178 (7.01)	_____
	After '93:	177 (6.97)	_____
Fork oil level (R)		_____	_____
(L)		_____	_____
Fork oil capacity (49 state/California type)	'90-'91:	383 cc (13.0 US oz, 13.4 Imp oz)	_____
	'92-'93:	386 cc (13.1 US oz, 13.5 Imp oz)	_____
	After '93:	412 cc (13.9 US oz, 14.5 Imp oz)	_____
(Canada type)	'90-'91:	394 cc (13.3 US oz, 13.8 Imp oz)	_____
	'92-'93:	386 cc (13.1 US oz, 13.5 Imp oz)	_____
	After '93:	412 cc (13.9 US oz, 14.5 Imp oz)	_____
Fork oil capacity (R)		_____	_____
(L)		_____	_____
Fork air pressure		_____	_____
Fork spring preload adjuster standard position (After '91)		3rd position from the top	_____
			_____
Steering bearing preload		0.1-0.15 kg	_____

Rear suspension

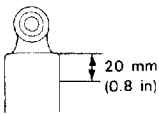
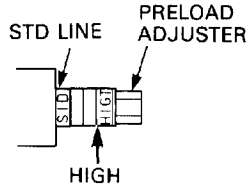
Item	Standard	Service limit
Shock absorber spring free length	'90-'91: 195.3 (7.69) '92-'93: 184.8 (7.28) After '93: _____	191.4 (7.54) 181.1 (7.13) _____
Shock absorber spring free length (R) (L)	_____	_____
Damper gas pressure	_____	_____
Damper compressed gas	_____	_____
Damper rod compressed force at 10mm (0.4 in) compressed	_____	_____
Damper drilling point for disposal	20 mm (0.8 in) from the top surface	_____
		
Shock absorber spring installed length (Standard)	'90-'91: 181.9 (7.16) '92-'93: 171.4 (6.75) After '93: _____	_____
		
Shock absorber spring compression adjuster range	LOW-STD-MIDDLE-HIGH POSITIONS	_____
Shock absorber spring direction	With tapered end facing upper spring seat.	_____
Recommended shock absorber oil	_____	_____
Shock absorber oil capacity	_____	_____
air pressure	_____	_____
Compression adjuster standard position	12 clicks from lowest position	_____
Rebound adjuster standard position	'92-'93: 1-1/8 turn from hardest position After '93: 1 turn from hardest position	_____

Brakes

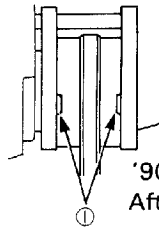
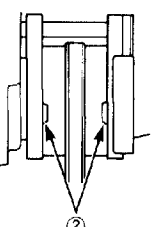
Front brake fluid	DOT4	_____
brake lever free play	_____	_____
brake pad wear indicator	_____	to the groove ①
		
brake disc thickness	'90-'93: 5.0 (0.21) After '93: 4.5 (0.18)	4.0 (0.20) 3.5 (0.14)
brake disc runout	_____	0.3 (0.012)
master cylinder I.D.	12.700-12.743 (0.5000-0.5017)	12.76 (0.502)
master piston O.D.	12.657-12.684 (0.4983-0.4994)	12.65 (0.498)
caliper cylinder I.D.	25.400-25.450 (1.0000-1.0020)	25.46 (1.002)
caliper cylinder I.D. (Upper)	_____	_____
(Lower)	_____	_____
caliper piston O.D.	25.335-25.368 (0.9974-0.9987)	25.33
caliper piston O.D. (Upper)	_____	_____
(Lower)	_____	_____
brake drum I.D.	_____	_____
brake lining thickness	_____	_____
Rear brake fluid	DOT4	_____
brake pedal height	_____	_____
brake pedal free play	_____	_____
brake pad wear indicator	_____	to the groove ②
		
brake disc thickness	6.0 (0.24)	5.0 (0.21)
runout	_____	0.3 (0.012)
master cylinder I.D.	12.700-12.743 (0.5000-0.5017)	12.76 (0.502)
master piston O.D.	12.657-12.684 (0.4983-0.4994)	12.65 (0.498)
caliper cylinder I.D.	27.000-27.050 (1.0629-1.0632)	27.06 (1.065)
caliper piston O.D.	26.918-26.968 (1.0598-1.0617)	26.91 (1.059)
brake drum I.D.	_____	_____
brake lining thickness	_____	_____

## General Information

Battery/charging system		
Item	Standard	Service limit
Alternator charging coil resistance (At 20°C/68° F)	0.1–1.0 Ω	_____
Regulator/rectifier regulated voltage/amperage	13.5–16V/5–9A at 5,000 rpm	_____
Battery capacity	12V–10AH	_____
Battery specific gravity (Full charged)	_____	_____
(Needs charging)	_____	_____
Battery charging rate (Normal)	1.2A (5–10 hours)	_____
(Quick)	5A (1 hour)	_____
Battery voltage (Fully charged at 20°C/68° F)	Over 13.1V	_____
(Needs charging at 20°C/68° F)	Below 12.5V	_____
Alternator lighting coil resistance (At 20°C/68° F)	_____	_____
AC regulator regulated voltage (With analogue type)	_____	_____
(With digital type)	_____	_____

Ignition system		
Spark plug		_____
'90–'93: (Standard NGK)	CR8EH9	_____
(Standard NIPPONDENSO)	U24FER9	_____
(For cold climate/below 5°C/41° F NGK)	_____	_____
(For cold climate/below 5°C/41° F NIPPONDENSO)	_____	_____
(For extended high speed riding NGK)	CR9EH9	_____
(For extended high speed riding NIPPONDENSO)	U27FER9	_____
After '93: (Standard NGK)	CR9EH9	_____
(Standard NIPPONDENSO)	U27FER9	_____
(For cold climate/below 5°C/41° F NGK)	CR8EH9	_____
(For cold climate/below 5°C/41° F NIPPONDENSO)	U24FER9	_____
(For extended high speed riding NGK)	_____	_____
(For extended high speed riding NIPPONDENSO)	_____	_____
Spark plug gap	0.8–0.9 (0.03–0.04)	_____
Ignition timing "F" mark	15° BTDC at idle	_____
Advance starts	2,000 rpm	_____
stops	_____	_____
Fully advance	_____	_____
Alternator exciter coil resistance (At 20°C/68° F)	_____	_____
Ignition coil resistance (At 20°C/68° F)		_____
Primary	2–4 Ω	_____
Secondary with plug cap	17–24 kΩ	_____
Secondary without plug cap	13–17 kΩ	_____
Ignition pulse generator resistance (At 20°C/68° F)	200–400 Ω	_____

Lights/meters/switches		Standard	Service limit
Item			
Main fuse		30A	—
Fuse		10A x 6, 20A x 1	—
Headlight (high/low beam)		12V 45/45W	—
Tail/brake light	'90-'93:	12V 32/3cp	—
	After '93:	12V 32/2cp	—
License light	'90-'93:	12V 4cp	—
	After '93:	12V 8W	—
Position light		—	—
Front turn signal/running light	'90-'93:	12V 32/3cp x 2	—
	After '93:	12V 23/8W x 2	—
Front turn signal light		—	—
Rear turn signal light	'90-'93:	12V 32cp x 2	—
	After '93:	12V 23W	—
Instrument light		12V 1.7W x 5	—
Oil pressure indicator	'90-'93:	12V 3.4W	—
	After '93:	12V 1.7W	—
Tail/brake light indicator		—	—
Side stand indicator	'90-'93:	12V 3.4W	—
	After '93:	12V 1.7W	—
Low fuel indicator	'90-'93:	12V 3.4W	—
	After '93:	12V 5W	—
Coolant temperature indicator		—	—
Oil temperature indicator		—	—
High beam indicator	'90-'93:	12V 3.4W	—
	After '93:	12V 1.7W	—
Turn signal indicator	'90-'93:	12V 3.4W x 2	—
	After '93:	12V 1.7W x 2	—
Neutral indicator	'90-'93:	12V 3.4W	—
	After '93:	12V 1.7W	—
Reverse indicator		—	—
Overdrive indicator		—	—
Oil temperature sensor resistance		—	—
Fuel unit resistance (At full level)		4-10 $\Omega$	—
(At low level)		90-100 $\Omega$	—
Fuel pump flow capacity (min./minute)		900 cc (30.4 US oz, 31.7 imp oz)/min.	—
Thermo sensor resistance (85°C/185° F)		39-49 $\Omega$	—
(120°C/248° F)		14-18 $\Omega$	—
Fan motor switch Starts to close (ON)		93-103°C (207-217° F)	—
Stops opening (OFF)		92-98°C (198-208° F)	—

# Torque Values

Standard			
Item	Torque N·m (kg-m, ft-lb)	Item	Torque N·m (kg-m, ft-lb)
5 mm bolt and nut	5 (0.5, 3.5)	5 mm screw	4 (0.4, 3)
6 mm bolt and nut	10 (1.0, 7)	6 mm screw	9 (0.9, 7)
8 mm bolt and nut	22 (2.2, 16)	6 mm flange bolt (8 mm head)	9 (0.9, 7)
10 mm bolt and nut	35 (3.5, 25)	6 mm flange bolt (10 mm head) and nut	12 (1.2, 9)
12 mm bolt and nut	55 (5.5, 40)	8 mm flange bolt and nut	27 (2.7, 20)
		10 mm flange bolt and nut	40 (4.0, 29)

Torque specifications listed below are for important fasteners. Others should be tightened to standard torque values listed above.

## '90-'93:

### NOTES:

1. Apply a locking agent to the threads.
2. Apply sealant to the threads.
3. Stake.
4. Apply oil to the seating surface and threads.

Engine ('90-'93)						
Item	Q'ty	Tread Dia (mm)	Torque			Remarks
			N·m	kg-m	ft-lb	
<b>Lubrication:</b>						
Oil pump driven sprocket bolt	1	6	18	1.8	13	NOTE 1
Oil pressure switch	1	—	12	1.2	9	NOTE 2
Oil drain bolt	1	12	38	3.8	27	
Oil pump mount bolt	3	6	12	1.2	9	
Oil filter	1	20	10	1.0	7	
Oil filter boss	1	20	18	1.8	13	NOTE 1
<b>Cylinder head/Cylinder:</b>						
Cylinder head cover bolt	8	6	10	1.0	7	
Camshaft holder bolt	32	6	12	1.2	9	
Cylinder head bolt	16	9	45	4.5	33	
	4	6	12	1.2	9	
Cam gear case bolt	8	6	10	1.0	7	
	2	8	23	2.3	17	
Thermosensor	1	—	10	1.0	7	NOTE 2
Spark plug	4	10	12	1.2	9	
<b>Clutch/Gearshift linkage:</b>						
Timing hole cap	1	45	18	1.8	13	
Slave cylinder bleed bolt	1	8	9	0.9	9	
Clutch center lock nut	1	22	90	9.0	65	NOTE 3
Gear shift return spring pin	1	8	25	2.5	18	
Shift drum bearing set plate bolt	2	6	12	1.2	9	
Shift drum center bolt	1	8	23	2.3	17	
<b>Crankcase/Crankshaft/Transmission:</b>						
Connecting rod cap nut	8	8	34	3.4	25	NOTE 4
Crankcase bolt 6 mm	15	6	12	1.2	9	
8 mm	1	8	23	2.3	17	
9 mm	8	9	33	3.3	24	NOTE 4
10 mm	2	10	40	4.0	29	
Mainshaft bearing set plate bolt	3	6	12	1.2	9	NOTE 1

## Engine ('90-'93)[cont'd]

Item	Q'ty	Tread Dia (mm)	Torque			Remarks
			N·m	kg-m	ft-lb	
Neutral switch	1	10	12	1.2	9	NOTE 1
Drive sprocket bolt	1	10	52	5.2	38	
<b>Alternator:</b>						
Alternator cover bolt	6	6	10	1.0	7	
Flywheel bolt	1	10	90	9.0	65	
<b>Starter clutch:</b>						
Starter motor terminal nut	1	6	4.5	0.45	3.3	
Starter clutch bolt	1	12	90	9.0	65	
Starter clutch cover bolt	3	8	40	4.0	30	
<b>Fuel system:</b>						
Carburetor band screw	6	5	1	0.1	0.7	

## Frame ('90-'93)

Item	Q'ty	Tread Dia (mm)	Torque			Remarks
			N·m	kg-m	ft-lb	
<b>Frame/Exhaust system</b>						
Exhaust pipe joint	8	8	30	3.0	22	NOTE 2 NOTE 2
Muffler mounting bolt	1	8	30	3.0	22	
Side stand pivot bolt	1	10	8	0.8	6	
Side stand pivot lock nut	1	10	40	4.0	29	
Side stand switch bolt	1	6	9	0.9	7	
<b>Cooling system</b>						
Thermo sensor	1	—	10	1.0	7	
Fan motor switch	1	16	18	1.8	13	
<b>Fuel system</b>						
Fuel fill cap mounting bolt	3	4	3	0.3	2.2	
<b>Engine mount</b>						
Engine mounting bolt	6	10	40	4.0	29	
Engine mount adjusting bolt	2	22	9	0.9	7	
Engine mount lock nut	2	22	55	5.5	40	
Rear lower engine mounting nut	1	12	55	5.5	40	
<b>Front</b>						
Front axle bolt	1	14	60	6.0	43	
Front axle pinch bolt	2	8	22	2.2	16	
Handlebar pinch bolt	2	8	23	2.3	17	
Handlebar weight bolt	2	6	10	1.0	7	
Fork pinch bolt	(Upper)	8	23	2.3	17	
	(Lower)	10	50	5.0	36	
Fork socket bolt	2	37	23	2.3	17	
Fork piston rod lock nut	2	10	20	2.0	14	
Steering stem nut	1	24	105	10.5	76	
Steering head bearing adjustment nut	1	26	25	2.5	18	
Ignition switch mounting bolt	2	8	25	2.5	18	NOTE 1
<b>Brake</b>						
Brake pipe flare nut	2	10	17	1.7	12	NOTE 4
Front caliper mount bolt	4	8	27	2.7	20	
Brake hose bolt	5	10	35	3.5	25	
Clutch fluid hose bolt	2	10	35	3.5	25	
Rear brake torque rod link bolt	2	10	35	3.5	25	

## General Information

Frame ('90-'93)[cont'd] Item	Q'ty	Tread Dia (mm)	Torque			Remarks
			N·m	kg-m	ft-lb	
Rear caliper stay bolt	2	8	27	2.7	20	
Rear caliper disc mount nut	4	8	35	3.5	25	
Front caliper disc mount bolt	12	8	43	4.3	31	
Foot peg mount bolt	4	8	33	3.3	24	
<b>Rear</b>						
Swingarm pivot lock nut (Left side)	1	18	95	9.5	69	
Swingarm pivot bolt	1	30	15	1.5	16	
Swingarm pivot lock nut	1	30	80	8.0	58	
Bearing holder pinch bolt	1	14	55	5.5	40	
Rear wheel nut	4	12	110	11	80	
Shock absorber mounting bolt	2	10	45	4.5	33	
Shock absorber joint lock nut	1	14	65	6.5	47	
Rear axle nut	1	35	195	19.5	141	
Driven sprocket nut	6	8	33	3.3	24	
Sub frame mount bolt	2	10	45	4.5	33	
	2	10	45	4.5	33	Socket bolt

## After '93:

- NOTE: 1. Apply locking agent to the threads  
 2. Apply sealant to the threads  
 3. Stake  
 4. Apply oil to the threads and seating surface  
 5. Apply grease to the threads and seating surface  
 6. A lock bolt. Do not reuse.

Engine (After '93)				
Item	Q'ty	Thread dia. (mm)	Torque N·m (kg-m, ft-lb)	Remarks
<b>Lubrication:</b>				
Oil pump driven sprocket bolt	1	6	18 (1.8, 13)	Note 1
Oil pressure switch	1	—	12 (1.2, 9)	Note 2
Oil drain bolt	1	12	30 (3.0, 22)	
Oil pump assembly bolt	3	6	13 (1.3, 9)	
Oil pipe bolt/nut	1/1	6	12 (1.2, 9)	
Oil filter	1	20	10 (1.0, 7)	Note 4
Oil filter boss	1	20	18 (1.8, 13)	Note 1
<b>Cooling System:</b>				
Water pump cover and mounting bolt	4	6	13 (1.3, 9)	
<b>Fuel System:</b>				
Carburetor insulator band screw	8	5	1 (0.1, 0.7)	
<b>Cylinder Head/Cylinder:</b>				
Cylinder head cover bolt	8	6	10 (1.0, 7)	
Camshaft holder bolt	32	6	12 (1.2, 9)	Note 4
Cylinder head bolt	16	9	45 (4.5, 33)	Note 4
	4	6	12 (1.2, 9)	
Cam gear case bolt	8	6	12 (1.2, 9)	
	2	8	27 (2.7, 20)	
Vacuum port joint	4	5	4 (0.4, 2.9)	
Sealing bolt	1	18	45 (4.5, 33)	Note 1
Spark plug	4	10	12 (1.2, 9)	

# General Information

Engine (After '93)[cont'd] Item	Q'ty	Thread dia. (mm)	Torque N•m (kg-m, ft-lb)	Remarks
<b>Clutch System:</b>				
Right crankcase cover bolt	13	6	12 (1.2, 9)	
Clutch lifter plate bolt	5	6	12 (1.2, 9)	
Clutch center lock nut	1	22	110 (11.0, 80)	Note 3, 4
Slave cylinder bleeder	1	8	9 (0.9, 6.5)	
Clutch fluid hose bolt	2	10	35 (3.5, 25)	
Clutch lever pivot bolt	1	6	1 (0.1, 0.7)	
nut	1	6	6 (0.6, 4.3)	
<b>Gearshift Linkage:</b>				
Gearshift return spring pin	1	8	23 (2.3, 17)	Note 1
Shift drum center bolt	1	8	23 (2.3, 17)	Note 1
Gearshift pedal pinch bolt	1	6	22 (2.2, 16)	
Drive sprocket cover rubber bolt	2	6	12 (1.2, 9)	Note 6
Chain guide plate bolt	2	6	12 (1.2, 9)	Note 1
Speed sensor bolt	2	6	10 (1.0, 7)	
<b>Crankshaft/Piston/Transmission:</b>				
Connecting rod cap nut	8	8	34 (3.4, 25)	Note 4
Crankcase bolt 6 mm	15	6	12 (1.2, 9)	
8 mm	1	8	23 (2.3, 17)	Note 4
9 mm	8	9	32 (3.2, 23)	Note 4
10 mm	2	10	40 (4.0, 29)	Note 4
Neutral switch	1	10	12 (1.2, 9)	
Drive sprocket bolt	1	10	52 (5.2, 38)	
<b>Charging System/Alternator:</b>				
Alternator cover bolt	6	6	12 (1.2, 9)	
Flywheel bolt	1	10	85 (8.5, 61)	Note 4
Stator bolt	4	6	12 (1.2, 9)	
<b>Ignition System:</b>				
Ignition pulse generator bolt	3	6	10 (1.0, 7)	
Timing hole cap	1	45	18 (1.8, 13)	Note 5
<b>Electric Starter/Starter Clutch:</b>				
Starter motor terminal nut	1	6	10 (1.0, 7)	
Starter clutch bolt	1	12	90 (9.0, 65)	Note 4
Starter clutch cover bolt	3	8	40 (4.0, 29)	Note 1
Starter motor assembly bolt	3	5	5 (0.5, 3.6)	

## Frame (After '93)

Item	Q'ty	Thread dia. (mm)	Torque N·m (kg-m, ft-lb)	Remarks
<b>Body Panels/Exhaust System/Sub Frame:</b>				
Exhaust pipe joint nut	11	6	12 (1.2, 9)	
Side stand pivot bolt	1	8	23 (2.3, 17)	
Footpeg stay bolt	4	8	27 (2.7, 20)	
Rear grab rail bolt	2	8	35 (3.5, 25)	
Sub frame mounting bolt	4	10	40 (4.0, 29)	
Fuel tank mounting bolt	1	6	11 (1.1, 8)	
<b>Cooling System:</b>				
Fan motor switch	1	16	18 (1.8, 13)	
Thermosensor	1	—	10 (1.0, 7)	Note 2
<b>Engine Mount:</b>				
Engine mounting bolt	6	10	40 (4.0, 29)	
Engine mount adjusting bolt	2	22	9 (0.9, 6.5)	
Engine mount lock nut	2	22	55 (5.5, 40)	
Rear lower engine mounting nut	1	12	55 (5.5, 40)	
<b>Front Wheel/Suspension/Steering:</b>				
Front axle bolt	1	14	40 (4.0, 29)	
Front axle pinch bolt	2	8	22 (2.2, 16)	
Handlebar pinch bolt	2	8	23 (2.3, 17)	
Front brake disc bolt	12	6	20 (2.0, 14)	Note 6
Fork pinch bolt	(Upper)	2	23 (2.3, 17)	
	(lower)	2	10	50 (5.0, 36)
Fork cap	2	37	23 (2.3, 17)	
Fork socket bolt	2	8	20 (2.0, 14)	Note 1
Fork piston rod lock nut	2	10	20 (2.0, 14)	
Steering stem nut	1	24	105 (10.5, 76)	
Steering head bearing adjustment nut	1	26	25 (2.5, 18)	Note 4
Ignition switch mounting bolt	2	8	25 (2.5, 18)	Note 1
<b>Rear Wheel/Suspension:</b>				
Rear axle nut	1	35	195 (19.5, 141)	Note 4
Rear brake disc bolt	4	8	35 (3.5, 25)	
Driven sprocket nut	6	8	33 (3.3, 24)	Note 4
Shock absorber mounting bolt	2	10	45 (4.5, 33)	
Shock absorber upper bracket nut	1	10	45 (4.5, 33)	
Shock link bolt	2	10	45 (4.5, 33)	
Shock arm plate bolt (swingarm side)	1	10	45 (4.5, 33)	
Swingarm pivot nut (left side)	1	18	95 (9.5, 69)	
Swingarm adjusting bolt	1	30	15 (1.5, 16)	
Swingarm pivot lock nut	1	30	80 (8.0, 58)	
Bearing holder pinch bolt	1	14	55 (5.5, 40)	
Rear brake torque rod link bolt	2	10	35 (3.5, 25)	

## General Information

Frame (After '93) [cont'd] Item	Q' ty	Thread dia. (mm)	Torque N•m (kg-m, ft-lb)	Remarks
<b>Brake System:</b>				
Brake hose bolt	4	10	35 (3.5, 25)	
Front brake pipe flare nut	2	10	17 (1.7, 12)	
Caliper bleed valve	2	8	5.5 (0.55, 4.0)	
Pad pin	2	10	18 (1.8, 13)	
Pad pin plug	2	10	2.5 (0.25, 1.8)	
Front caliper mounting bolt	2	8	27 (2.7, 20)	Note 6
Rear caliper stay bolt	2	8	27 (2.7, 20)	
Caliper pin bolt	(Front) 1	8	23 (2.3, 17)	Note 1
	(Rear) 1	8	28 (2.8, 20)	
Caliper bracket pin bolt	2	8	13 (1.3, 9)	Note 1
Front brake lever pivot bolt	1	6	1 (0.1, 0.7)	
nut	1	6	6 (0.6, 4.3)	
Rear master cylinder mounting bolt	2	6	12 (1.2, 9)	
Rear master cylinder reservoir bolt	1	6	12 (1.2, 9)	

# Tools

- The tools for bearing removal and installation are not contained in this list. Refer to section 1, Ball Bearing Replacement, of the Common Service Manual.
- The newly designed tools are indicated with \* mark in the list.

Description	Tool number	Remarks	Ref. sect(s)
Vacuum gauge	07404-0030000	or M937B-021-XXXX (U.S.A. only)	3
Drive chain cutter	07HMH-MR10102	Drive chain (After '93)	3
-Link plate holder	07NMH-MW00110 or		
	07PMH-MZ20110		
Pilot screw wrench		Carburetor	3
'90-'93:	07908-4730002		
After '93: (Canada type)	07908-4220201		
(49 state/California)	07KMA-MS60101 and		
	07PMA-MZ20110		
Oil filter wrench	07HAA-PJ70100	Oil filter	4
Oil pressure gauge	07506-3000000	or equivalent commer-	4
Oil pressure gauge attachment	07510-4220100	cially available in	4
Antifreeze tester	Commercially available	U.S.A.	5
Cooling system tester	Commercially available		5
Float level gauge	07401-0010000	Carburetor	6
Lock nut wrench	07HMA-MR70200	Engine mount	7
*Pivot lock nut wrench	07908-4690002	Swingarm	7, 13
Valve guide driver	07HMD-ML00100	Valve guide	8
Tappet hole protector	07HMG-MR70001	Valve	8
Valve spring compressor	07757-0010000		8
Valve spring compressor attachment	07959-KM30101		8
Valve seat cutter, 24.5 mm (45° EX)	07780-0010100	or equivalent commer-	8
Valve seat cutter, 29 mm (45° IN)	07780-0010300	cially available in	8
Valve flat cutter, 25 mm (32° EX)	07780-0012000	U.S.A.	8
Valve flat cutter, 30 mm (32° IN)	07780-0012200		8
Valve interior cutter, 30 mm (60° IN)	07780-0014000		8
Valve interior cutter, 26 mm (60° EX)	07780-0014500		8
Cutter holder, 4.5 mm	07781-0010600		8
Valve guide reamer, 4.5 mm	07HMH-ML00101	or equivalent commer-	8
Compression gauge	07305-0010000	cially available in	8
Compression gauge attachment	07JMJ-KY20100 or	U.S.A.	8
	07PMJ-MY50100		
Clutch center holder	07724-0050001	Clutch	9
Lock nut wrench 26 x 30 mm	07716-0020203		9
Driver	07746-0030100	Mainshaft bearing	11
Attachment, 25 mm I.D.	07746-0030200		11
Bearing remover head, 20 mm	07746-0050600	Front wheel bearing	12
Bearing remover shaft	07746-0050100		12
Driver	07749-0010000		
Attachment, 42x 47 mm	07746-0010300	Front wheel bearing	12, 13
		Rear axle housing	
		Driven sprocket hub	
Pilot, 20 mm	07746-0040500	Front wheel bearing	12, 13
Fork seal driver	07947-KA50100	Swingarm	12
Fork seal driver attachment	07947-KF00100	Fork	12
Lock nut wrench, 30 x 32 mm	07716-0020400	Steering	12
Steering stem socket	07916-3710100		12
Ball race remover set	07946-KM90001	Steering head	12
- Driver attachment A	07946-KM90100	Included in set	
- Driver attachment B	07946-KM90200		
- Driver shaft assembly	07946-KM90300		
- Bearing remover A	07946-KM90401		
- Bearing remover B	07946-KM90500		
- Base assembly	07946-KM90600		
Steering stem driver	07946-MB00000		

# General Information

Tool (cont'd) Description	Tool number	Remarks	Ref. sect(s)
Shock absorber compressor	07GME-0010000	Shock absorber ('90-'93)	13
Shock absorber compressor attachment	07959-MB10000		
*Shock absorber compressor attachment	07NME-MY70100	Shock absorber ('90-'93)	13
Bearing remover	07936-3710300	Shock link ('90-'93)	13
Bearing remover handle	07936-3710100		
Bearing remover weight	07741-0010201	Shock arm ('90-'93) shock link and swing-arm (After '93)	13
Bushing pin driver assembly	07GMD-KT80100		
Attachment, 24 x 26 mm	07746-0010700		
Pilot, 17 mm	07746-0040400	Driven sprocket hub	13
Pilot, 35 mm	07746-0040800		
Pilot, 40 mm	07746-0040900		
Attachment, 52 x 55 mm	07746-0010400		
Attachment, 62 x 68 mm	07746-0010500	Rear axle housing	13
Driver shaft	07946-MJ00100	Driven sprocket hub	13
Needle bearing remover	07HMC-MR70100	Swingarm	13
Attachment, 37 x 40 mm	07746-0010200		
Pilot, 28 mm	07746-0041100		
Bearing remover set	07936-3710001	Included in set	
- Bearing remover	07936-3710600		
- Bearing remover handle	07936-3710100		
- Bearing remover weight	07741-0010201		
Digital multimeter	KS-AHM-32-003	U.S.A. only	15, 16
Analogue multimeter	07308-0020001 (SANWA) or TH-5H (KOWA)		15
Snap ring pliers	07914-3230001	Master cylinder(s)	9, 14
Rotor puller	07733-0020001	Alternator	15
Flywheel holder	07725-0040000	Alternator	15
Gear holder	07724-0010100	Starter clutch	17

# Lubrication & Seal Points

'90-'93:

Engine	Point	Material	Remarks
	<ul style="list-style-type: none"> <li>• Intake and Exhaust valve stem sliding surface</li> <li>• Primary sub gear hole</li> <li>• Connecting rod small end-piston pin sliding surface</li> <li>• Transmission gear shifter groove</li> <li>• Crankshaft main journal bearing sliding surface</li> <li>• Connecting rod bearing sliding surface</li> <li>• Cam lobe</li> <li>• Camshaft journal</li> </ul>	Molybdenum disulfide oil (mixture of engine oil and molybdenum disulfide grease in a 1 : 1 ratio)	
	<ul style="list-style-type: none"> <li>• Upper crankcase mating surface</li> </ul>	Liquid sealant	Do not apply sealant to the oil passages and near the main journal bearings
	<ul style="list-style-type: none"> <li>• Oil pressure switch</li> <li>• Oil filter boss</li> <li>• Thermosensor</li> <li>• Fan motor switch</li> </ul>	Sealant	Do not apply sealant to the oil pressure switch thread head.
	<ul style="list-style-type: none"> <li>• Sliding surface (Piston, Valve lifter, Clutch outer)</li> <li>• Cylinder head-to-Case 9 mm bolt head mating surface</li> <li>• Connecting rod cap nut mating surface</li> <li>• Gear teeth</li> </ul>	Engine oil	

Frame	Point	Material	Remarks
	<ul style="list-style-type: none"> <li>• Center stand pivot</li> <li>• Side stand pivot</li> <li>• Brake pedal pivot</li> <li>• Gearshift pedal pivot</li> <li>• Steering head bearings</li> <li>• Dust seal lips</li> <li>• Clutch lever pivot</li> <li>• Throttle cable ends</li> <li>• Swingarm pivot bearings</li> <li>• Seat locking tab</li> <li>• Wheel bearings</li> <li>• Speedometer gear</li> </ul>	Multipurpose grease	
	<ul style="list-style-type: none"> <li>• Brake caliper seals</li> <li>• Caliper-piston sliding surface</li> <li>• Master cylinder and clutch slave piston cup(s)</li> <li>• Master cylinder-piston sliding surface</li> <li>• Clutch slave-piston sliding surface</li> </ul>	DOT 4 brake fluid	
	<ul style="list-style-type: none"> <li>• Brake caliper pivots</li> <li>• Brake caliper pivot boots</li> <li>• Rear brake master cylinder push rod head</li> <li>• Clutch slave cylinder push rod head</li> </ul>	Silicone grease	
	<ul style="list-style-type: none"> <li>• Speedometer cable</li> <li>• Throttle cable</li> <li>• Choke cable</li> </ul>	Light weight oil	
	<ul style="list-style-type: none"> <li>• Handlebar grip inside surface</li> </ul>	Honda Bond A or Honda Hand Grip Cement (U.S.A. only)	

After '93

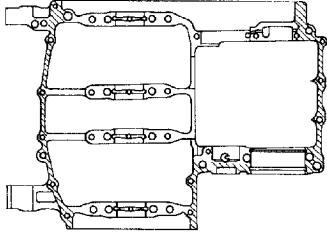
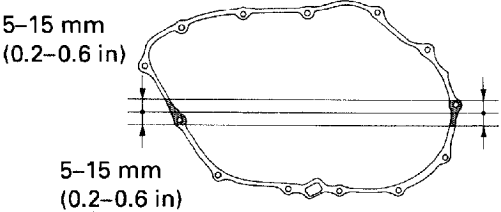
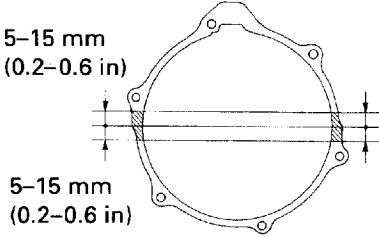
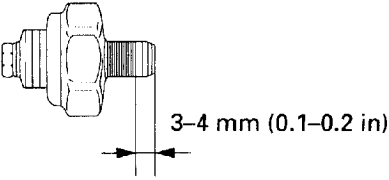
Engine	Location	Material	Remarks
<p>Upper and lower crankcase mating surface</p>  <p>Right crankcase cover gasket surfaces of the crankcase</p>  <p>Alternator cover gasket surfaces of the crankcase</p>  <p>Oil pressure switch threads</p> 	<p>Liquid sealant</p>	<p>Apply to the area as shown.</p> <p>Apply to the area as shown.</p> <p>Apply to the area shown.</p> <p>Do not apply sealant to the thread head as shown.</p>	
<p>Semicircular portions of the cylinder head Alternator wire grommet seating surface Thermosensor threads</p>	<p>Sealant</p>	<p>Do not apply sealant to the sensor head.</p>	

Engine (cont'd)	Location	Material	Remarks
Oil filter boss threads (crankcase side) Alternator wire clamp bolt Oil pump driven sprocket bolt threads Shift drum bearing set plate bolt threads Shift drum center bolt threads Gearshift return spring pin Starter clutch cover bolt threads Stator mounting bolt threads Mainshaft bearing setting plate bolt threads Chain guide plate bolt Cylinder head 18 mm sealing bolt Upper crankcase 8 mm sealing bolt Right crankcase cover plate bolt Drive sprocket cover bolt (lower crankcase-alternator cover bolt: 6 x 35 mm)		Locking agent 	Apply area: 5.5-7.5 mm
Cylinder head cover packing (cover side)		Honda bond A	
Camshaft journals and lobes Valve stem (valve guide sliding surface) Valve lifter sliding surfaces Crankshaft main journal bearing sliding surfaces Connecting rod bearing sliding surfaces Connecting rod small end-piston pin sliding surfaces Transmission gear shift fork grooves Primary drive gear-sub gear sliding surfaces Clutch outer inner surface Gear teeth and rotating surfaces Other sliding surfaces		Molybdenum disulfide oil (a mixture of 1/2 engine oil and 1/2 molybdenum disulfide grease)	
Cylinder head bolt (9 mm) threads and seating surfaces Connecting rod nut/bolt threads and seating surfaces Piston and piston pin hole sliding surfaces Piston rings sliding surfaces Upper/lower crankcase bolt (8 mm/9 mm/10 mm) threads and seating surfaces Camshaft holder bolt threads Clutch center lock nut threads and seating surfaces Clutch disc sliding surfaces Clutch outer needle bearing inner surface Flywheel bolt threads and seating surfaces Starter clutch bolt threads and seating surfaces Oil filter cartridge threads and seating surfaces Bearings O-rings		Engine oil	
Carburetor synchronization screw tip portions Timing hole cap threads Oil seal lips		Multi-purpose grease	

## General Information

Frame	Location	Material	Remarks
	Rear axle bearing holder needle bearing	Molybdenum disulfide grease	
	Rear axle bearing holder ball bearings Swingarm pivot bearings Shock absorber lower bearing Shock link bearings Drive sprocket hub O-ring Steering head bearings Steering head dust seal lips Side stand pivot Center stand pivot Seat lock hook Throttle grip pipe flange and cable end Rear brake pedal pivot Footpeg pivot Dust seal lips	Multi-purpose grease	
	Throttle cable Choke cable	Cable lubricant	
	Caliper piston Brake/clutch master piston and cup	DOT4 brake fluid	
	Brake caliper piston seals Brake caliper pin bolt Caliper bracket pin bolt Clutch slave cylinder push rod head Clutch slave cylinder piston seal Brake lever pivot Brake lever adjuster arm piston contacting surface Clutch lever pivot Clutch lever push rod head and pivot	Silicone grease	
	Steering bearing adjustment nut threads Rear axle nut Rear wheel driven sprocket nut	Engine oil	
	Front fork dust seal lips Front fork oil seal lips	Fork fluid	
	Handlebar grip rubbers Brake caliper pad retainer seating surface	Honda bond A or equivalent	
	Front fork socket bolt threads Front brake caliper pin bolt threads Front/rear caliper bracket pin bolt threads Cooling fan nut threads Speedometer reset knob screw threads Shock absorber joint lock nut Ignition switch mounting bolts	Locking agent	

# Cable & Harness Routing

'90-'93:

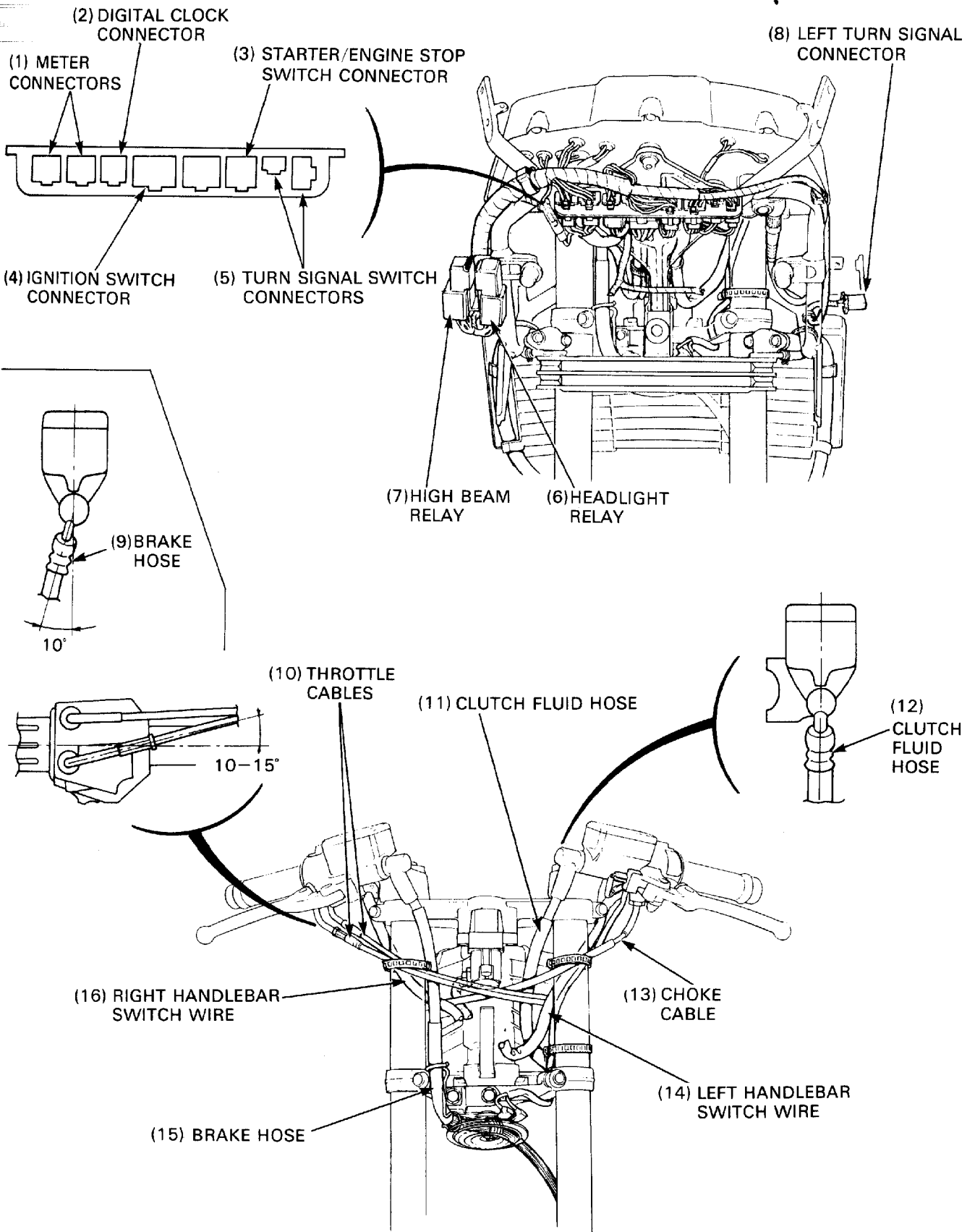

'90-'93:

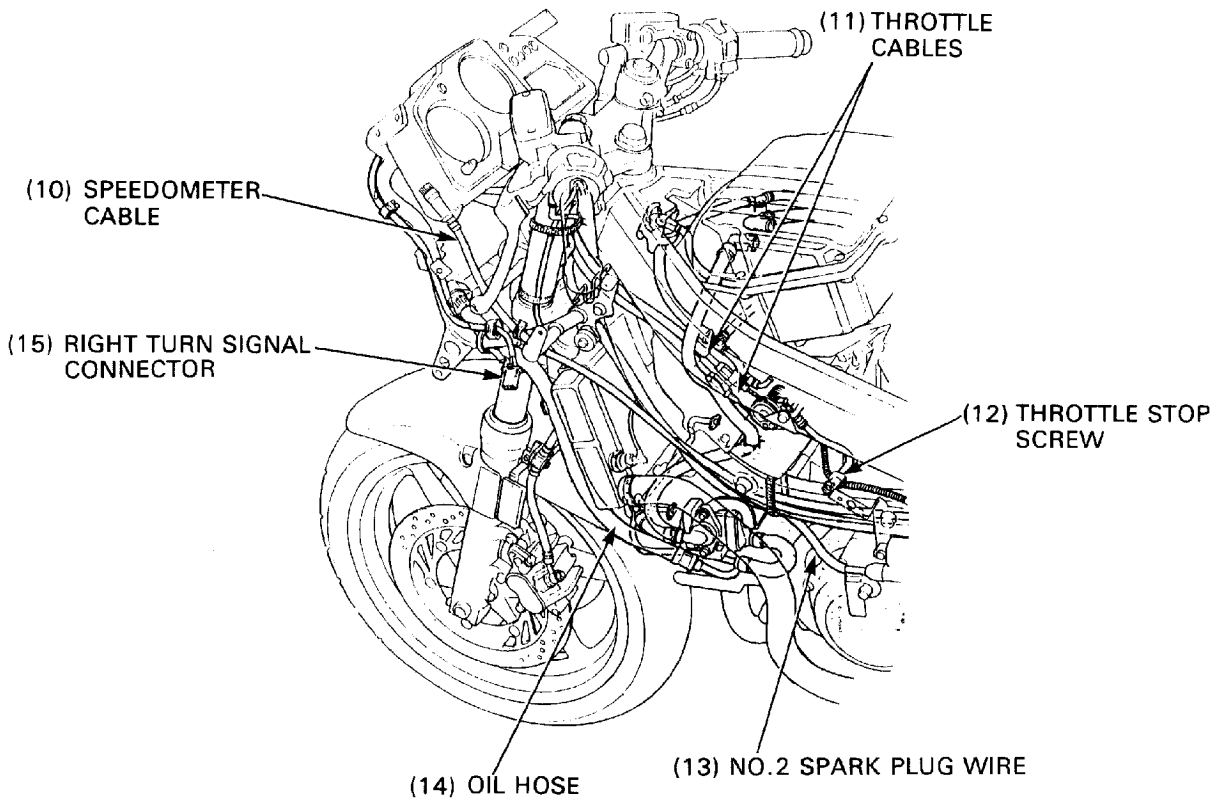
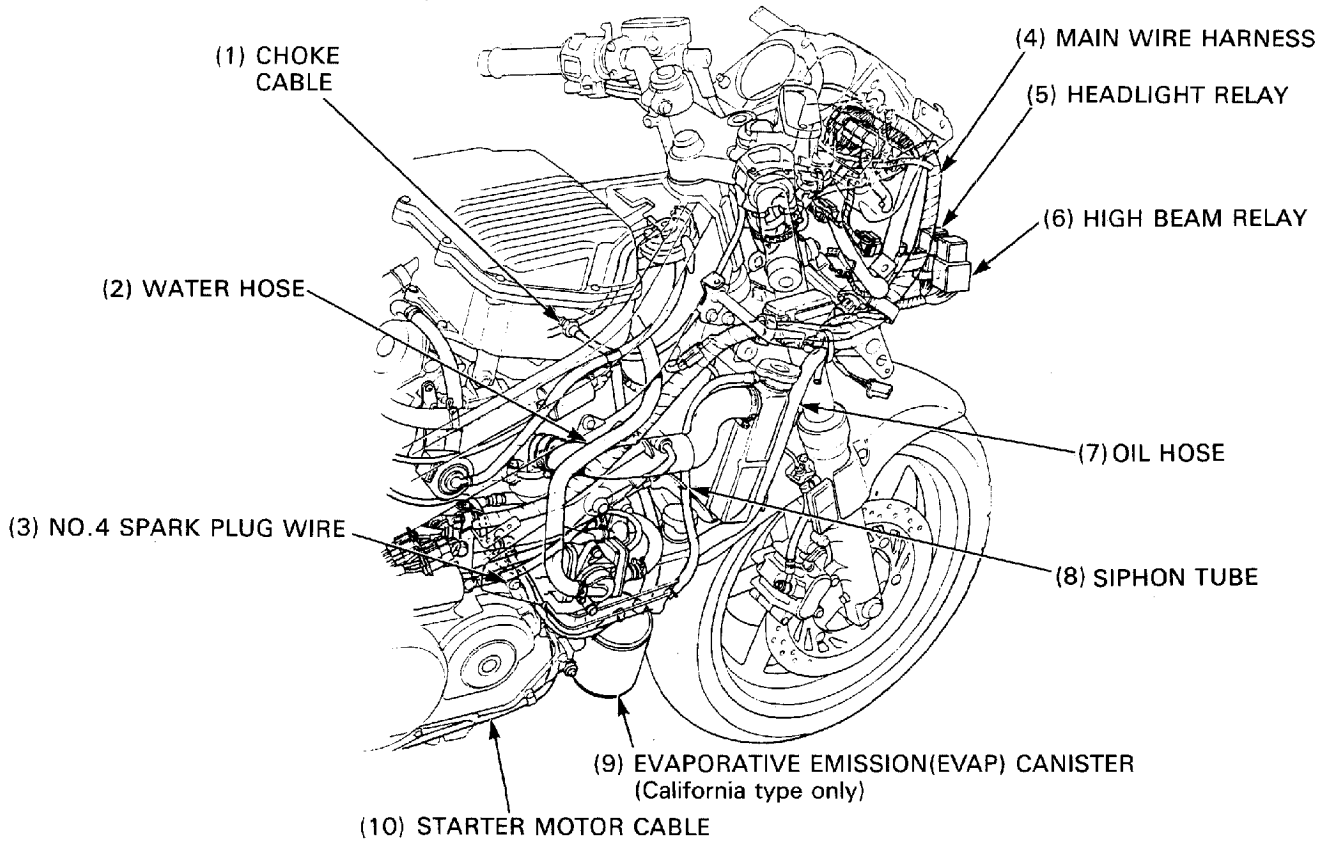

'90-'93:

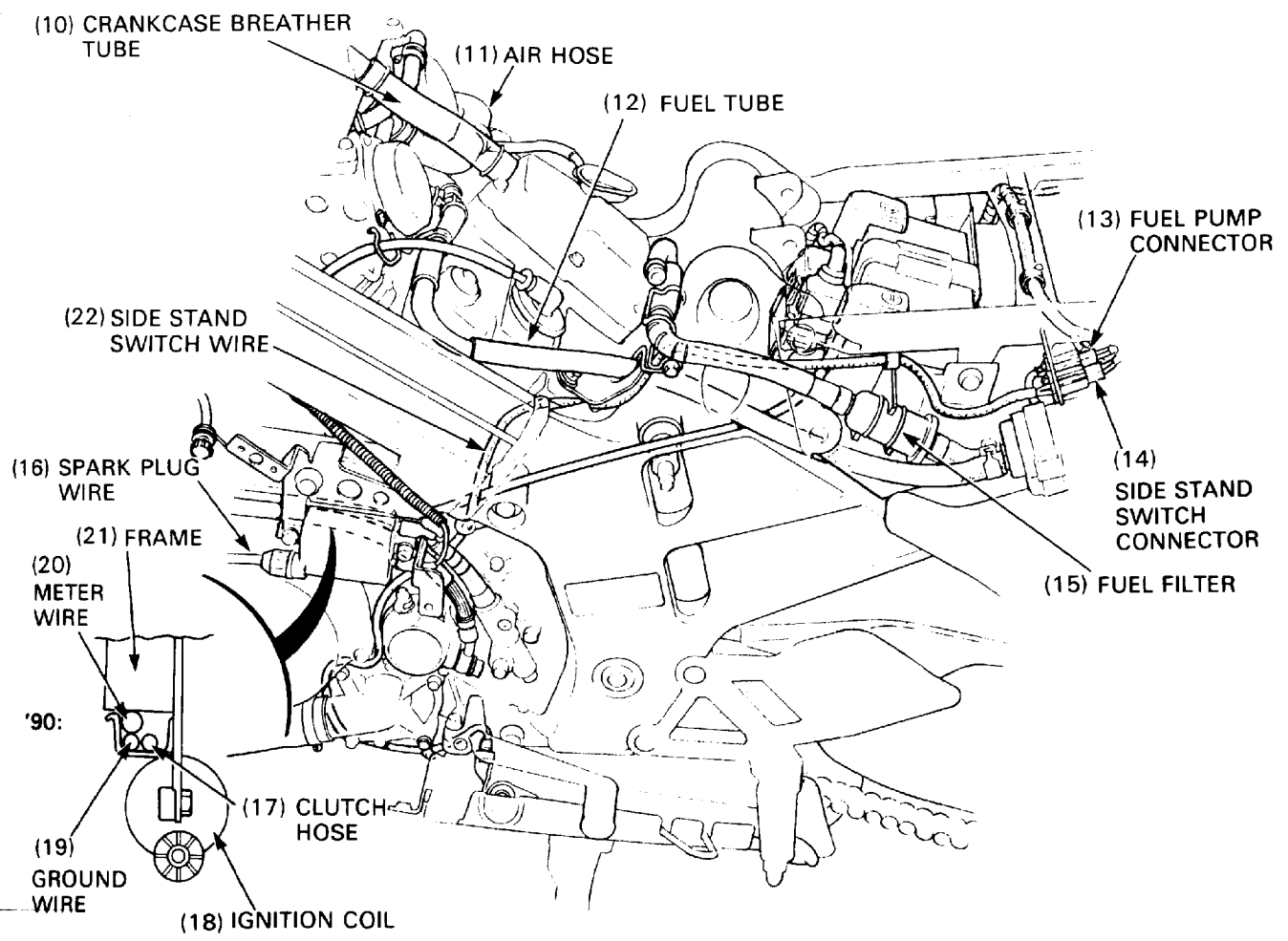
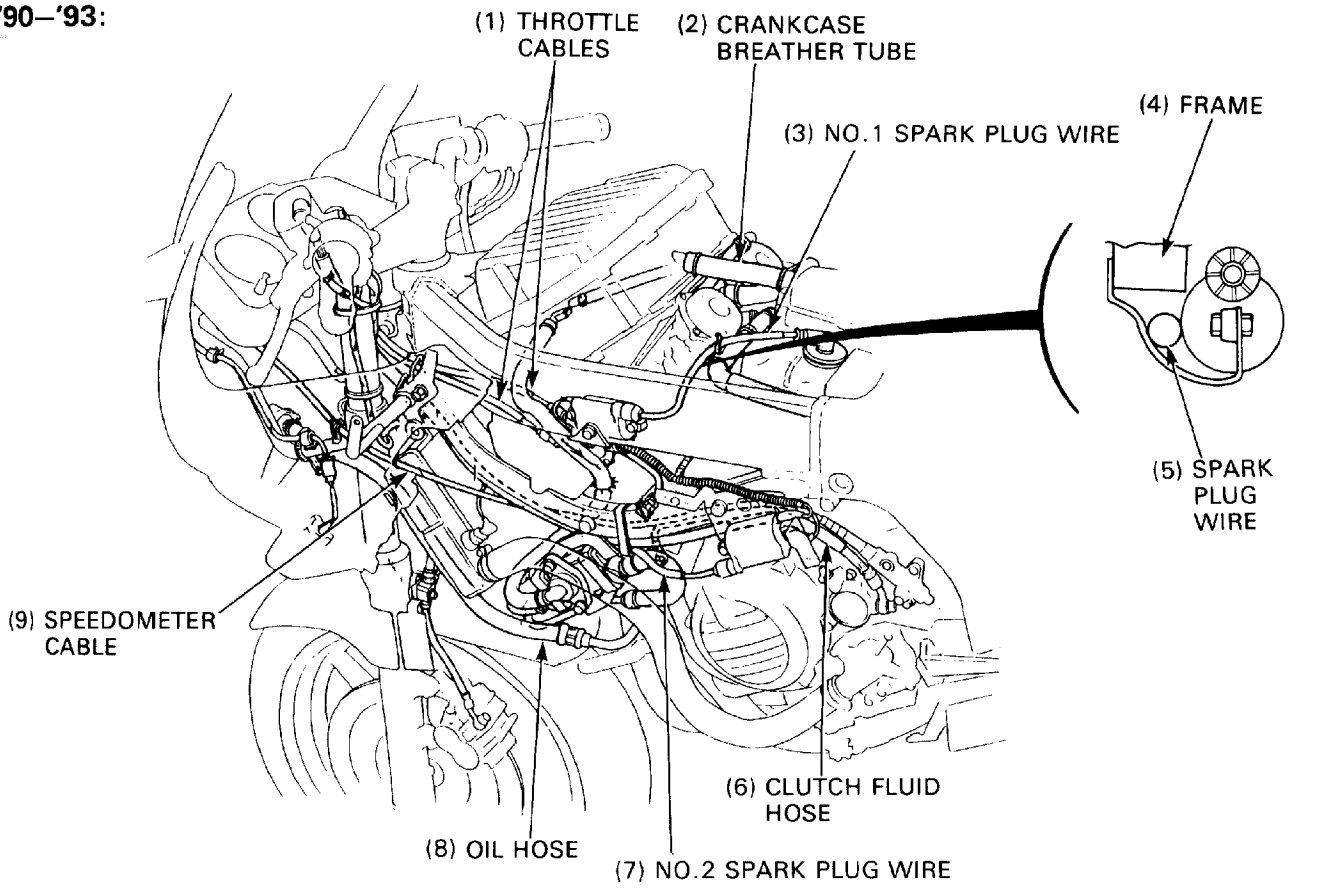

'90-'93:

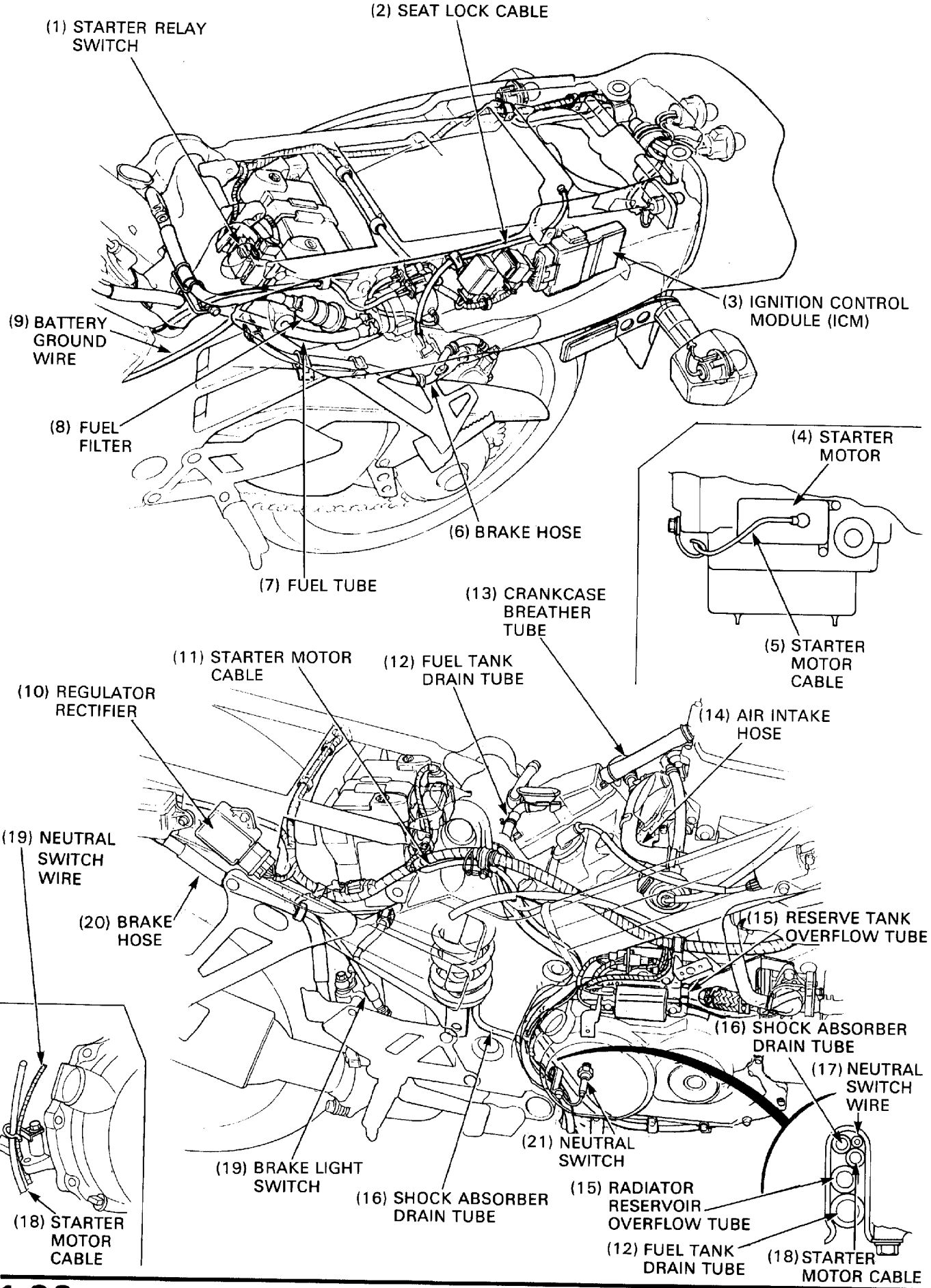

'90-'93:

(2) EVAPORATIVE EMISSION CARBURETOR  
AIR VENT (EVAP CAV) CONTROL VALVE  
(California type)

(1) AIR INTAKE  
HOSES  
(49 state/  
California type)

(3) AIR HOSE

(4) FUEL INLET  
TUBE

(7) EVAPORATIVE  
EMISSION  
(EVAP) PURGE  
CONTROL VALVE  
(California type)

(6) CRANKCASE  
BREATHER TUBE

(5) FUEL TUBE

(8) BRAKE  
HOSE

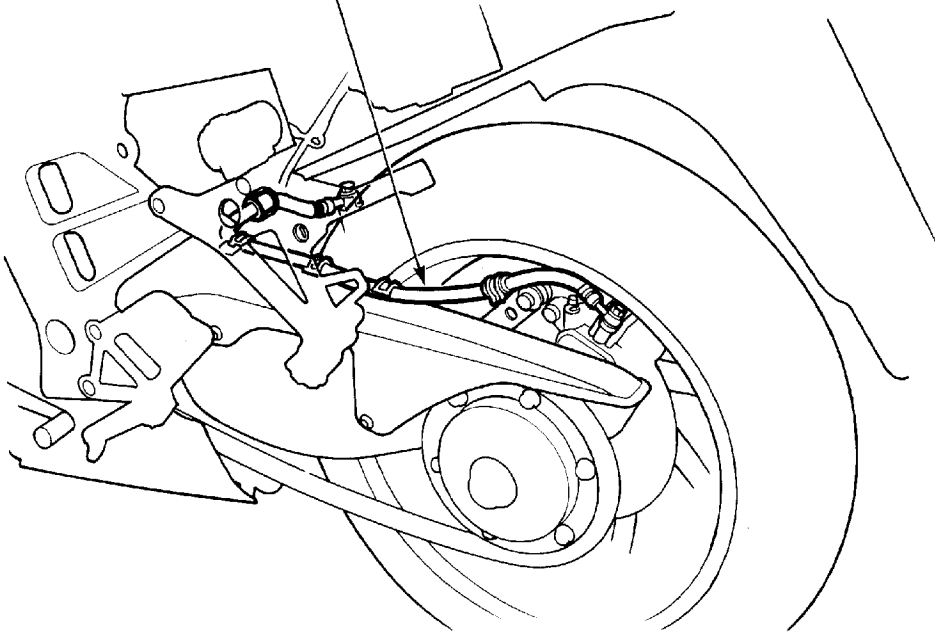

After '93:

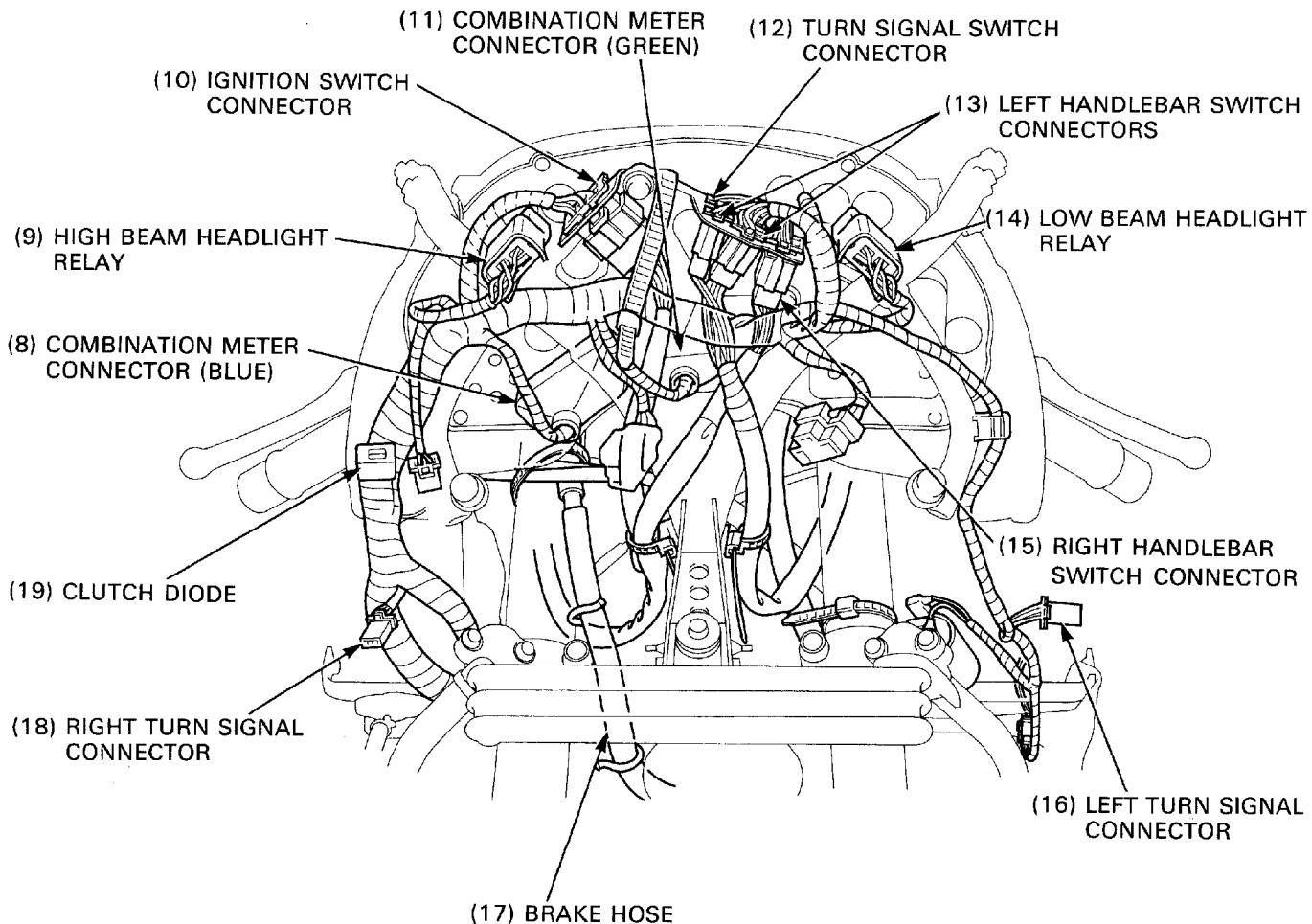
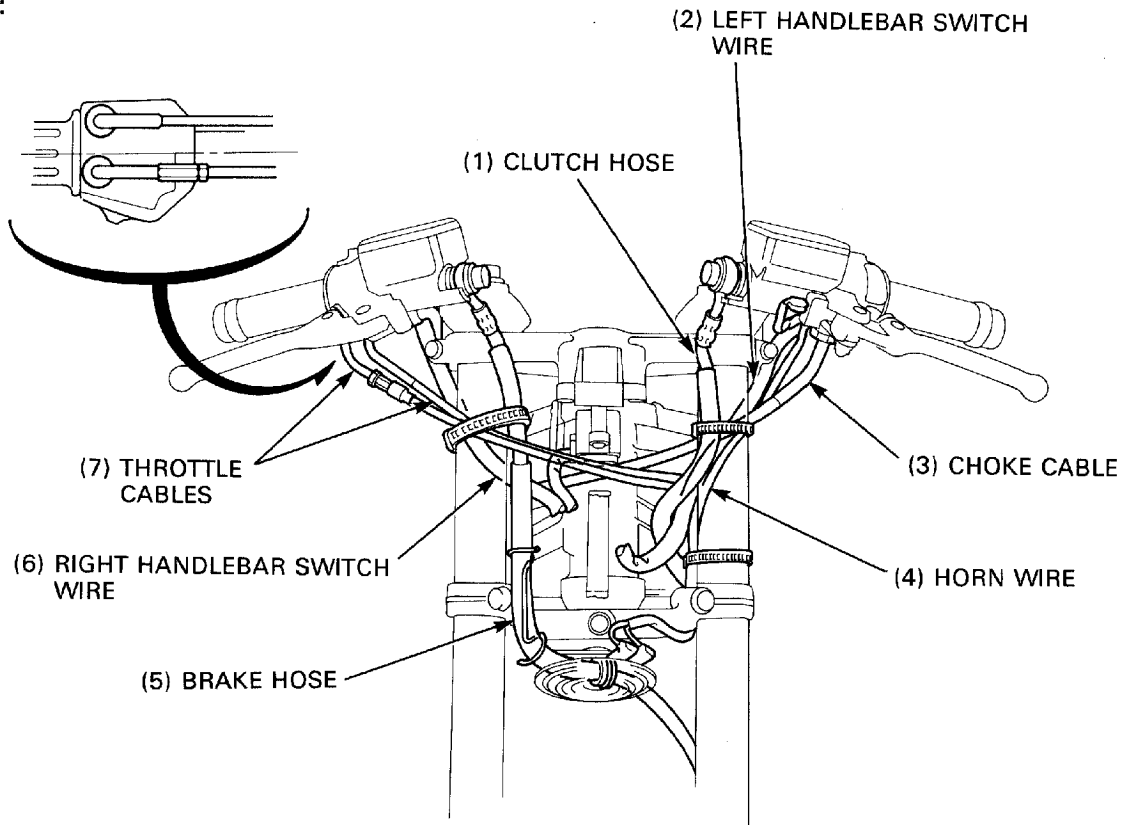

After '93:

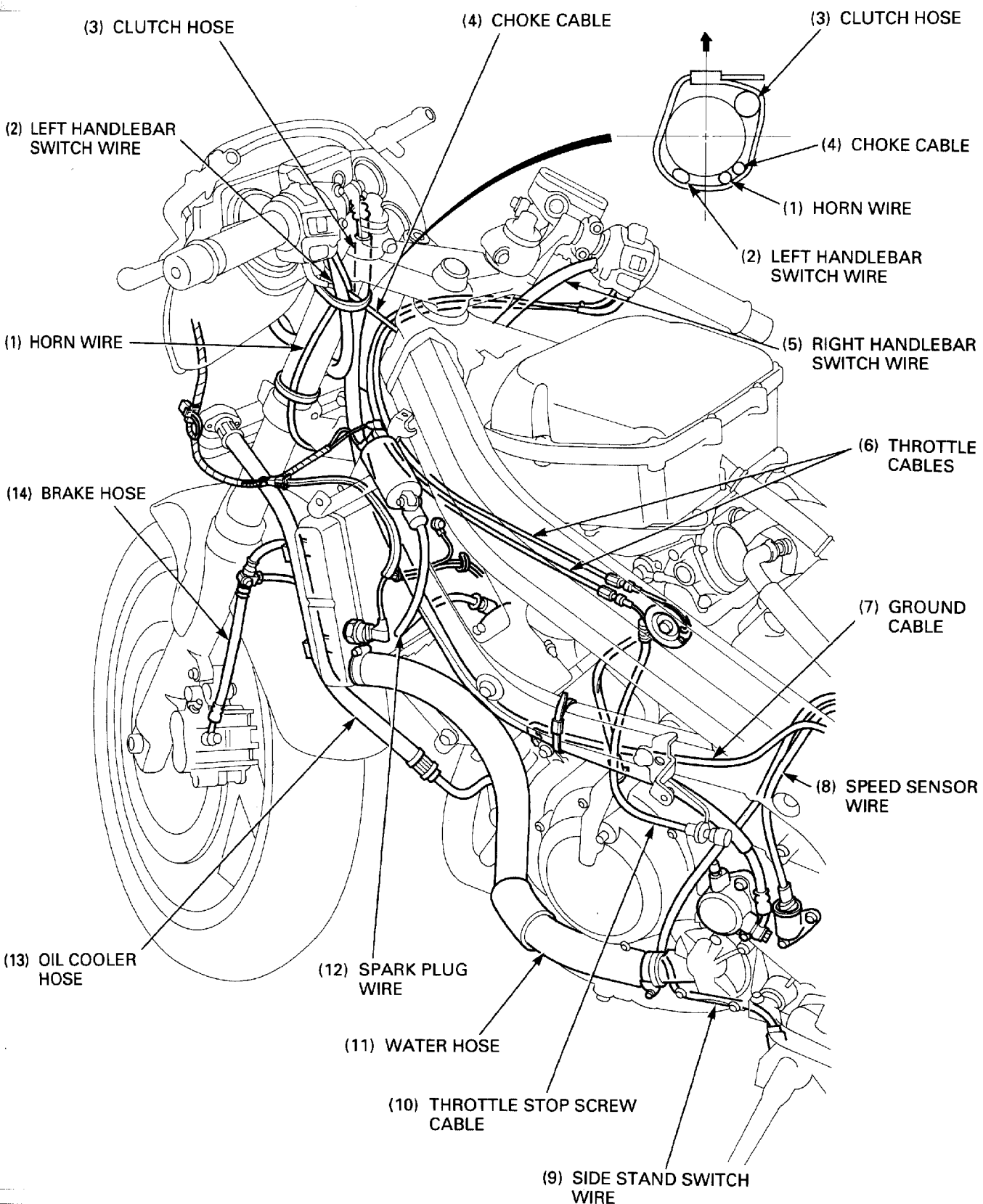

After '93:

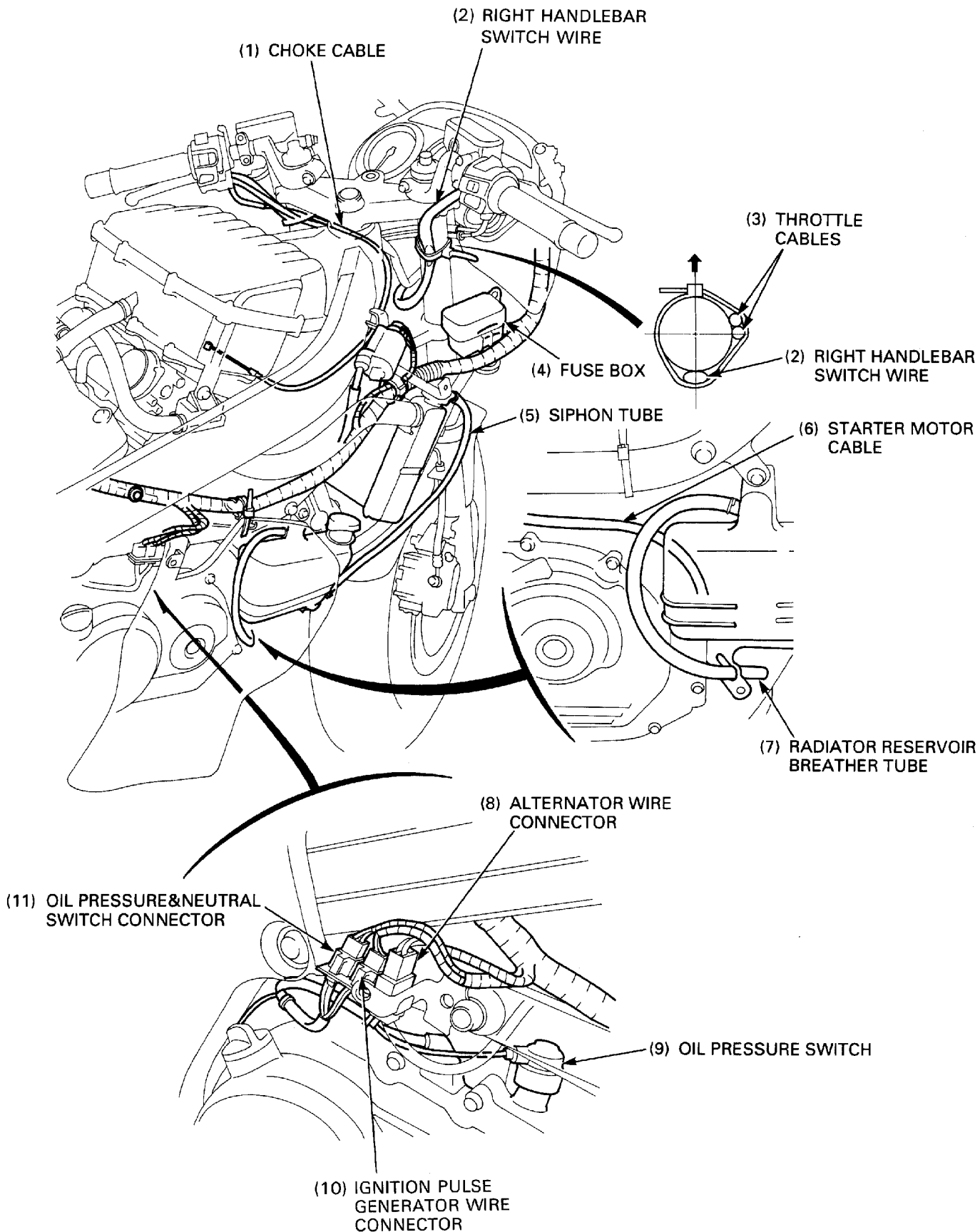

After '93:

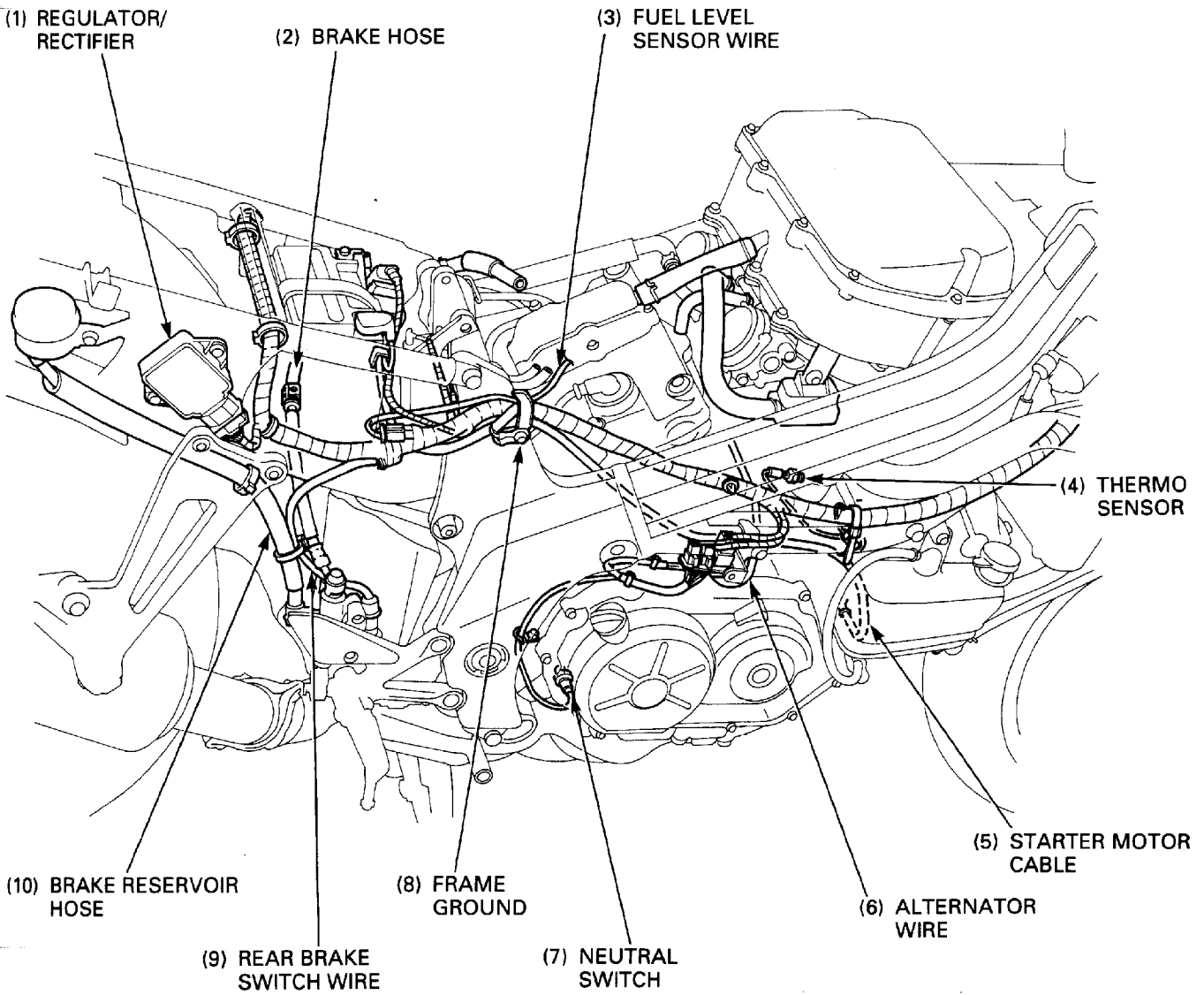

After '93:

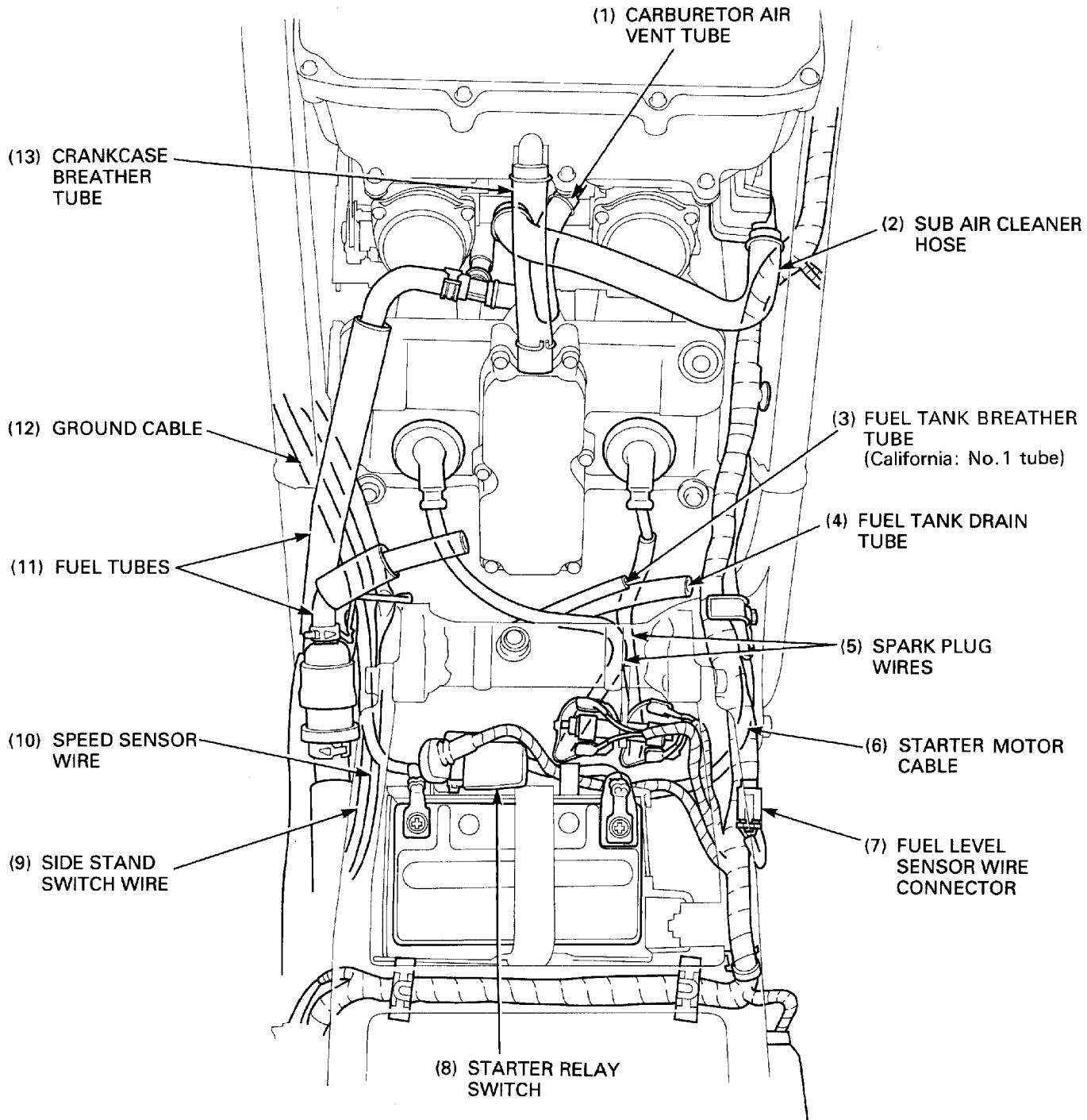

After '93:

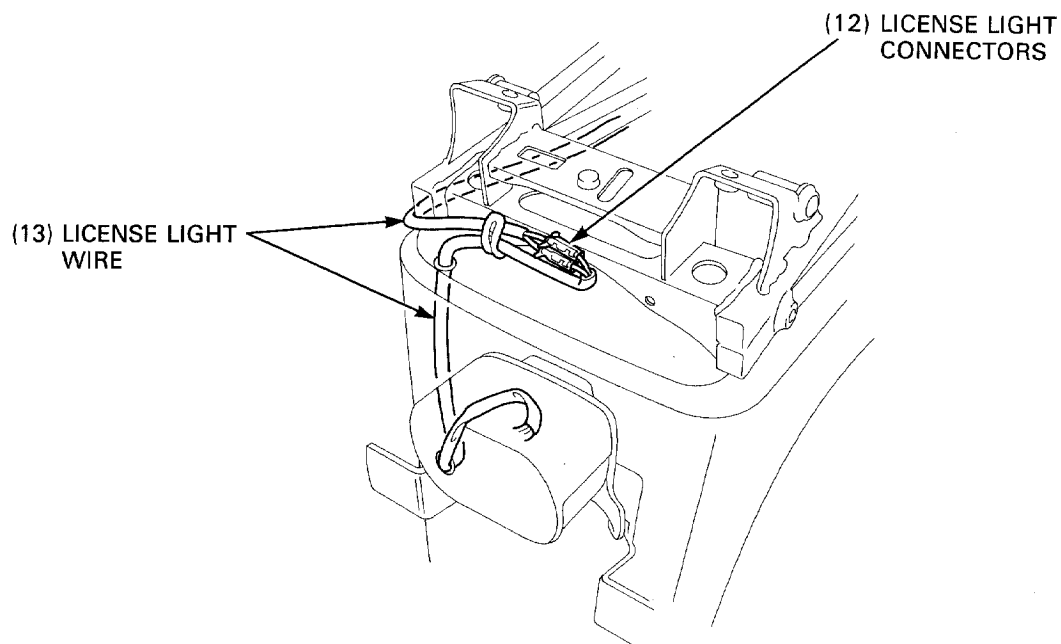
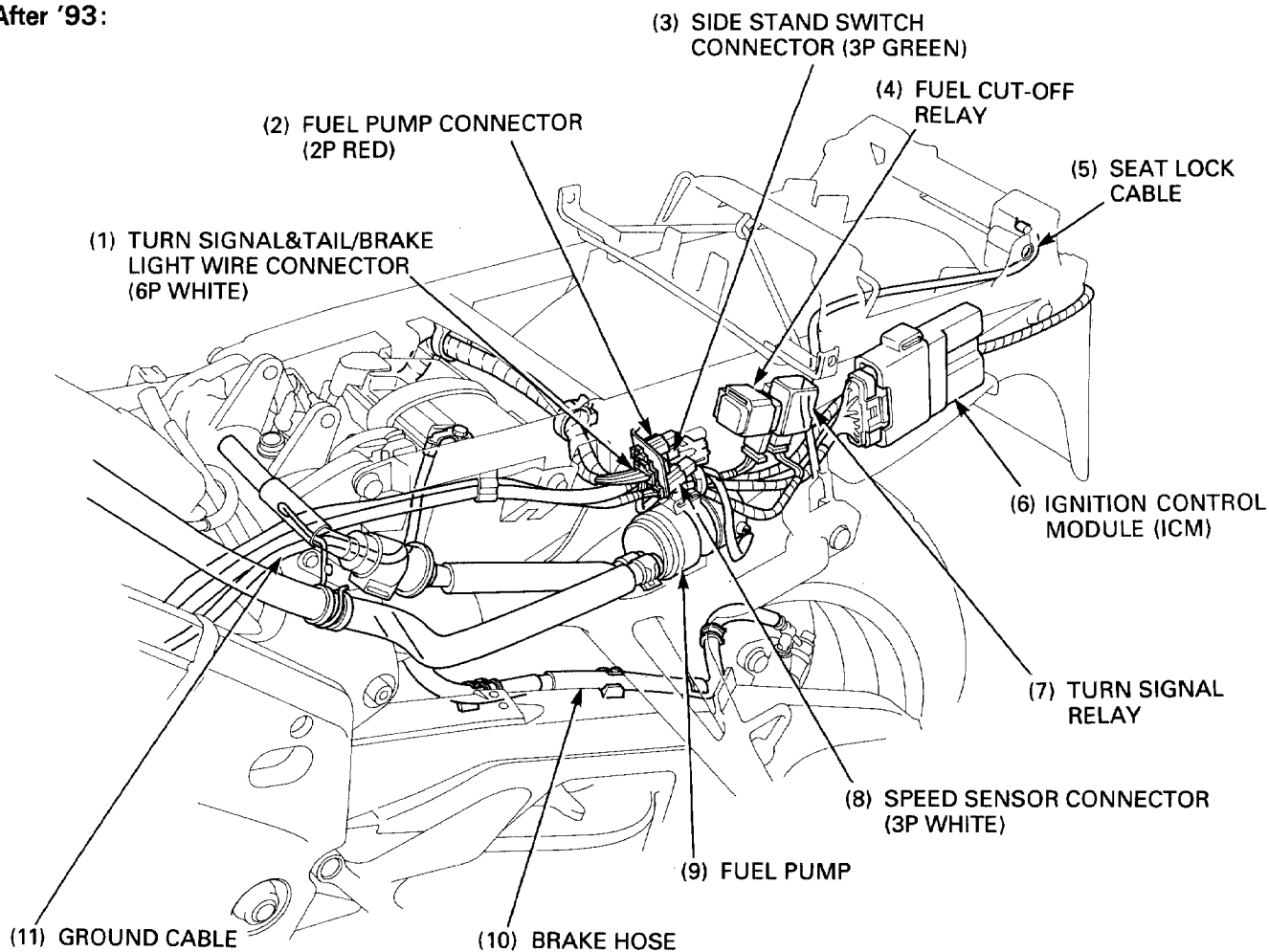

After '93:

(49 state/California type)

(3) EVAPORATIVE EMISSION (EVAP)  
PURGE CONTROL VALVE  
(California only)

(4) No. 4 TUBE

(2) No. 5 TUBE

(1) No. 11 TUBE

(6) AIR SUCTION HOSE  
(No. 15)

(5) TO AIR CLEANER HOUSING

(7) TO FRONT CYLINDER  
HEAD INTAKE PORT

(10) FRONT AIR INJECTION  
PIPES (No. 16)

(8) VACUUM TUBE  
(No. 10)

(9) PULSE SECONDARY AIR INJECTION  
(PAIR) CONTROL VALVE

After '93:

(49 state/California type)

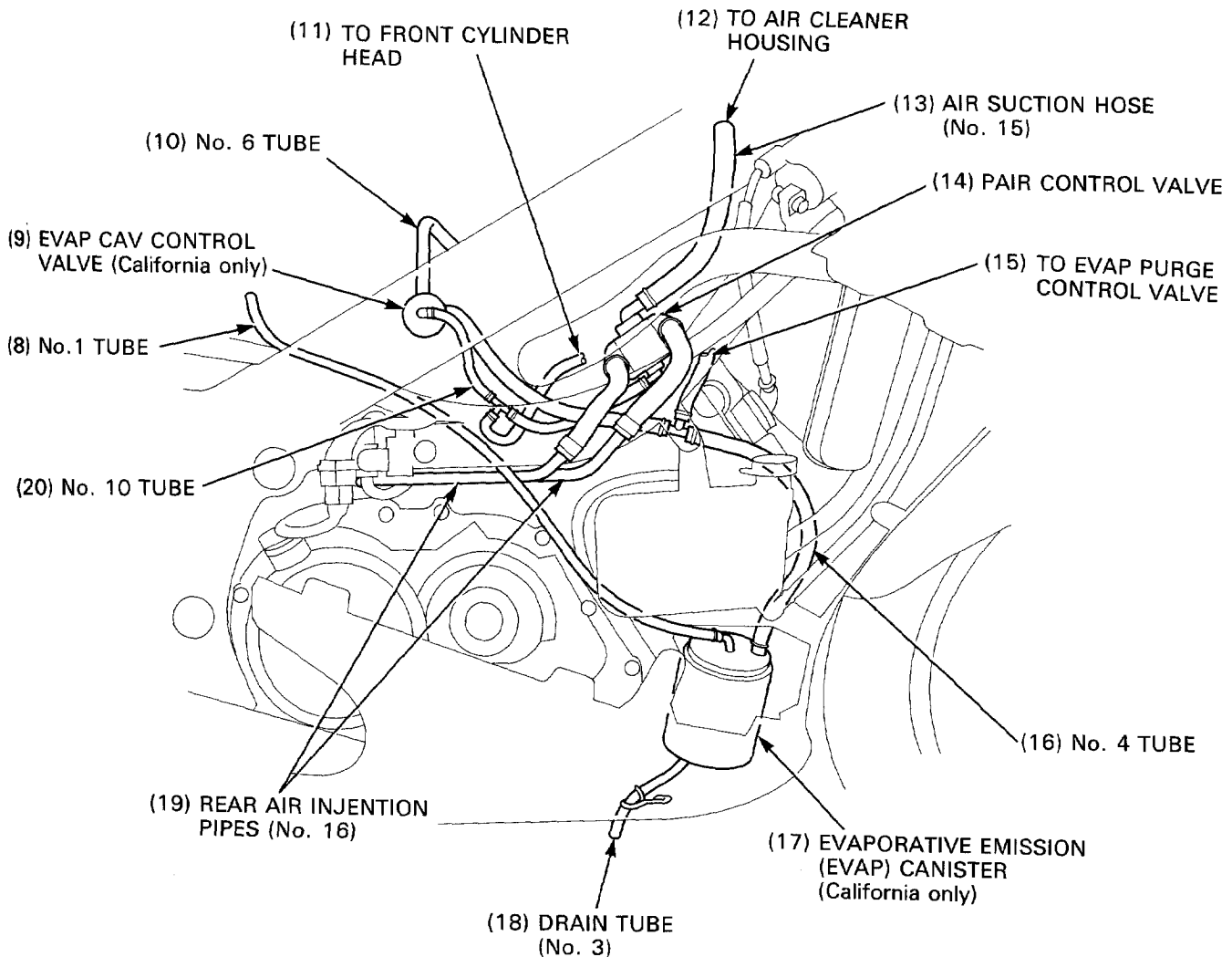
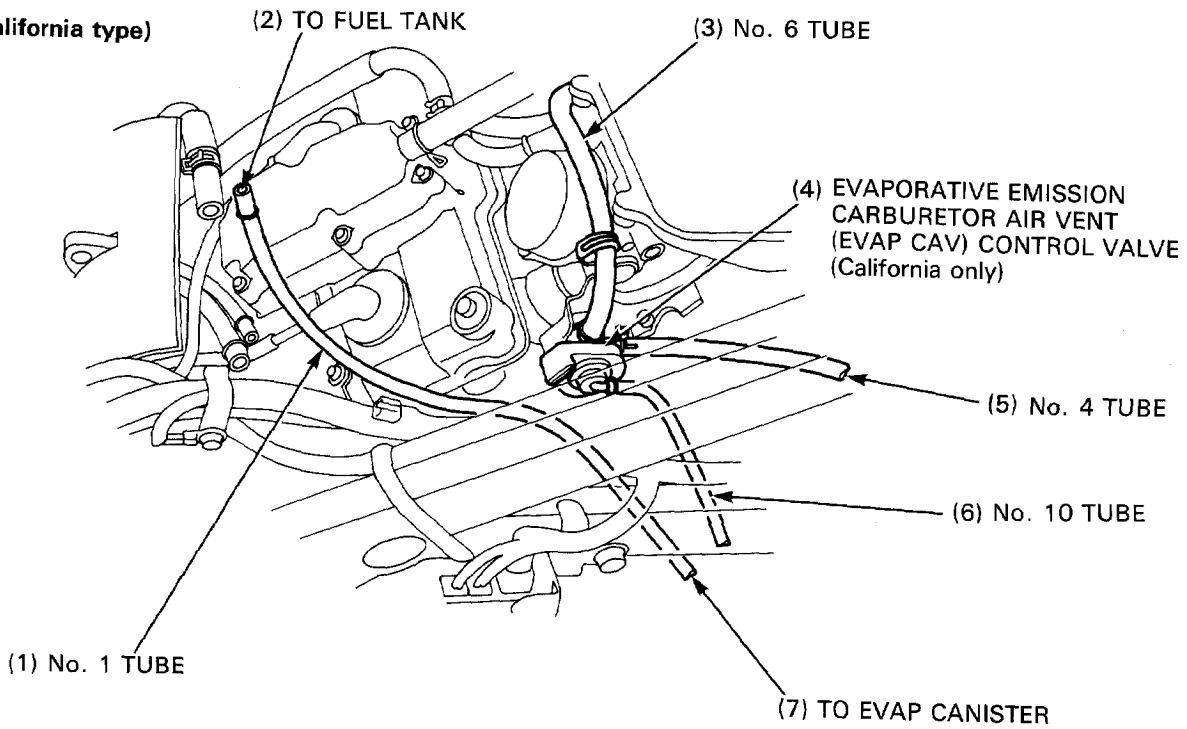

## Emission Control Systems

The U.S. Environmental Protection Agency and California Air Resources Board (CARB) require manufactures to certify that their motorcycles comply with applicable exhaust emissions standards during their useful life, when operated and maintained according to the instructions provided, and that motorcycles built after January 1, 1983 comply with applicable noise emission standards for 1 year or 6,000 km (3,730 miles) after the time of sale to the ultimate purchaser, when operated and maintained according to the instructions provided. Compliance with the terms of the Distributor's Warranties for Honda Motorcycle Emission Control Systems is necessary in order to keep the emissions system warranty in effect.

### Source of Emissions

The combustion process produces carbon monoxide and hydrocarbons. Control of hydrocarbons is very important because, under certain conditions, they react to form photochemical smog when subjected to sunlight. Carbon monoxide does not react in the same way, but it is toxic.

Honda Motor Co., Ltd. utilized lean carburetor settings as well as other systems, to reduce carbon monoxide and hydrocarbons.

### Crankcase Emission Control System

The engine is equipped with a closed crankcase system to prevent discharging crankcase emissions into the atmosphere. Blow-by gas is returned to the combustion chamber through the air cleaner and the carburetor.

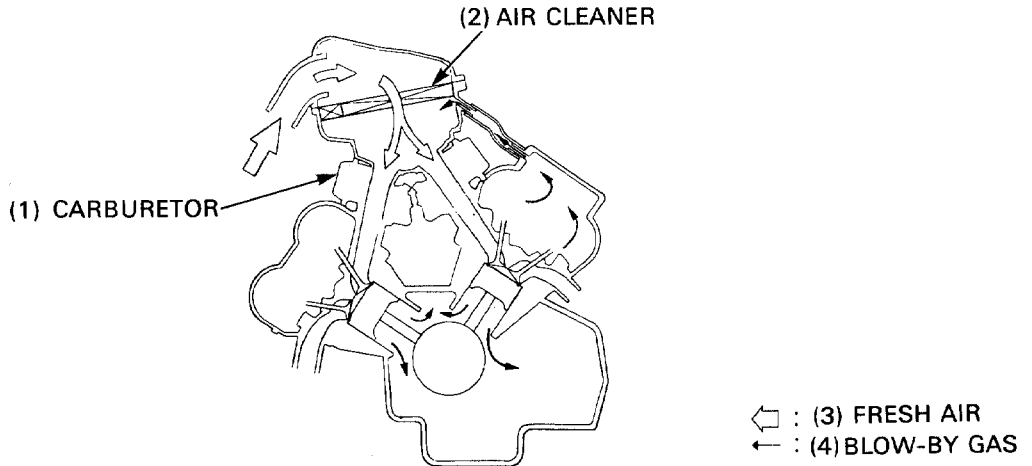

### Exhaust Emission Control System (Secondary Air Supply System) (U.S.A. only)

The exhaust emission control system consists of a secondary air supply system which introduces filtered air into the exhaust gases in the exhaust port. No adjustments to secondary air supply system should be made, although periodic inspection of the components is recommended. The secondary air supply system helps improve emission performance.

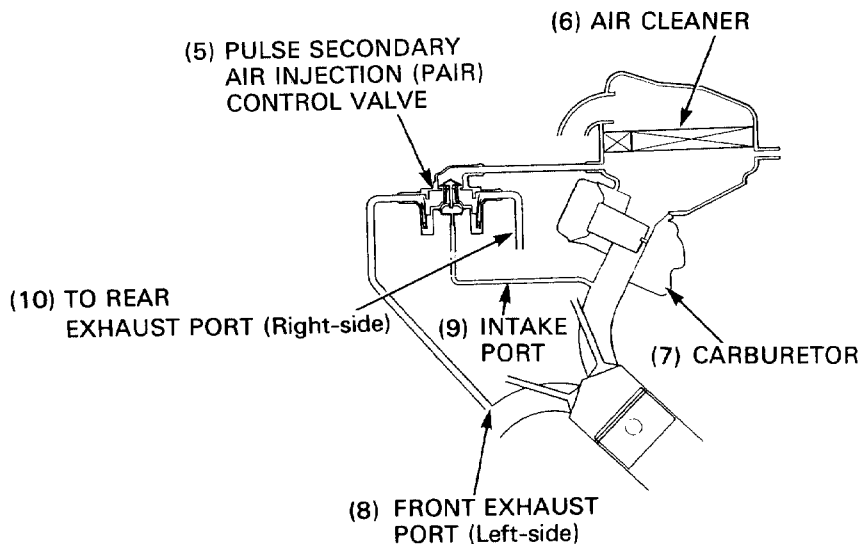

## Evaporative Emission Control System (California type only)

This model complies with California Air Resources Board evaporative emission requirements.

Fuel vapor from the fuel tank and carburetor is directed into the EVAP canister where it is adsorbed and stored while the engine is stopped. When the engine is running and the EVAP purge control valve is open, fuel vapor in the EVAP canister is drawn into the engine through the carburetor.

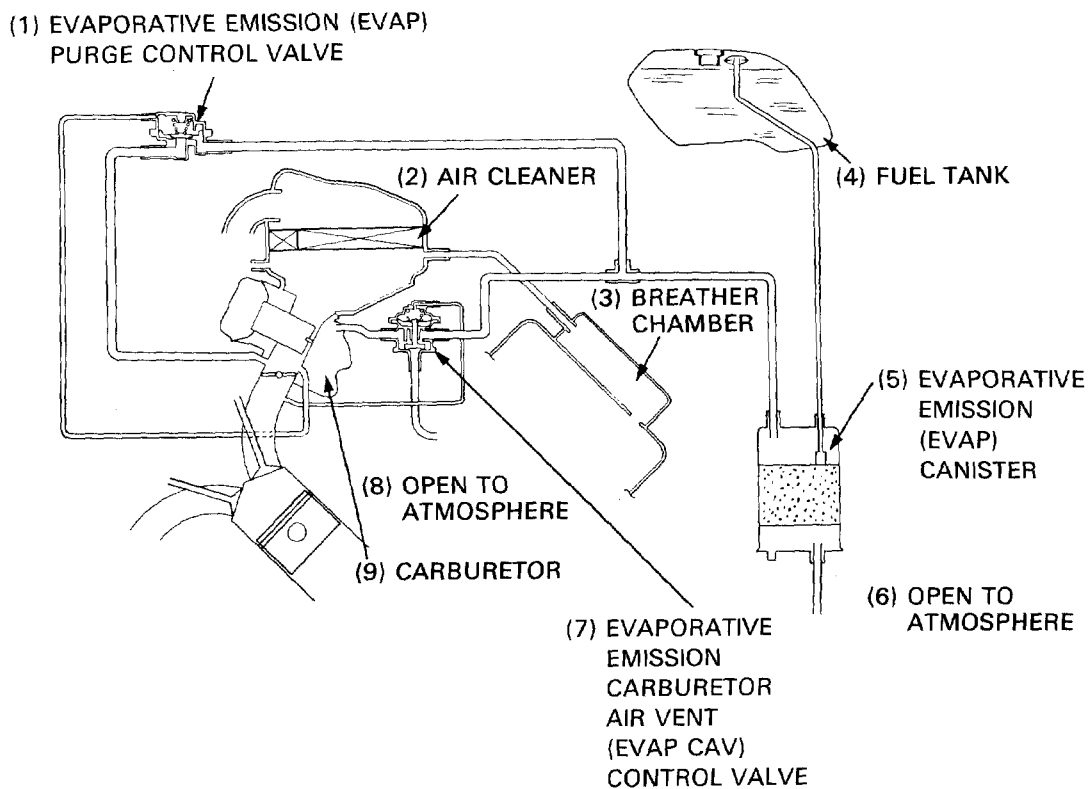

## Noise Emission Control System

**TAMPERING WITH THE NOISE CONTROL SYSTEM IS PROHIBITED:** Federal law prohibits the following acts or the causing thereof: (1) The removal or rendering inoperative by any person, other than for purposes of maintenance, repair or replacement, of any device or element of design incorporated into any new vehicle for the purpose of noise control prior to its sale or delivery to the ultimate purchaser or while it is in use; or (2) the use of the vehicle after such device or element of design has been removed or rendered inoperative any person.

**AMONG THOSE ACTS PRESUMED TO CONSTITUTE TAMPERING ARE THE ACTS LISTED BELOW:**

1. Removal of, or puncturing of the muffler, baffles, header pipes or any other component which conducts exhaust gases.
2. Removal of, or puncturing of any part of the intake system.
3. Lack of proper maintenance.
4. Replacing any moving parts of the motorcycle, or parts of the exhaust or intake system, with parts other than those specified by the manufacturer.

# Emission Control Information Labels (U.S.A. only)

## Vehicle Emission Information Label

An emission control information label is attached to the rear fender beneath the seat as shown. The seat must be removed to read it. It gives basic tune-up specifications.

## Vehicle Emission Control Information Update Label

After making a high altitude carburetor adjustment, attach an update label on the rear fender as shown.

Instructions for obtaining the update label are given in Service Letter number 132.

When readjusting the carburetors back to the low altitude specification, be sure to remove this update label.

## Vacuum Hose Routing Diagram Label (California type only)

The vacuum hose routing diagram label is attached on the rear fender beneath the seat. The seat must be removed to see it.

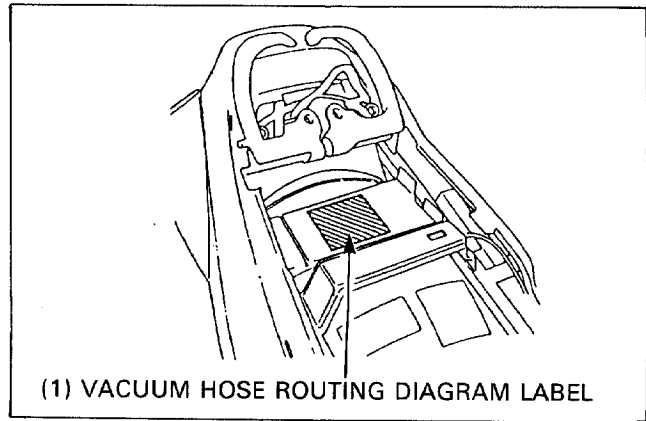
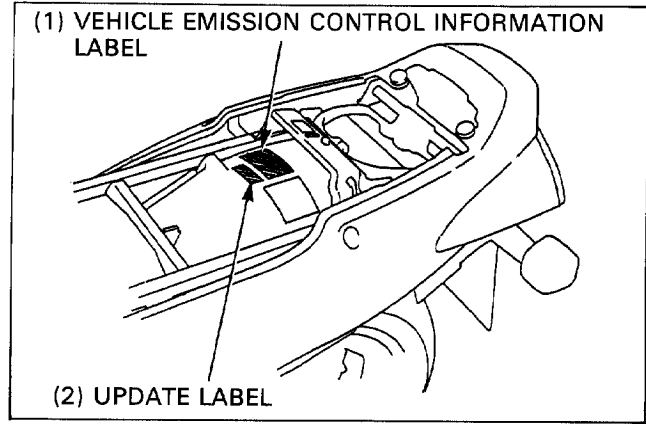

'90-'93:

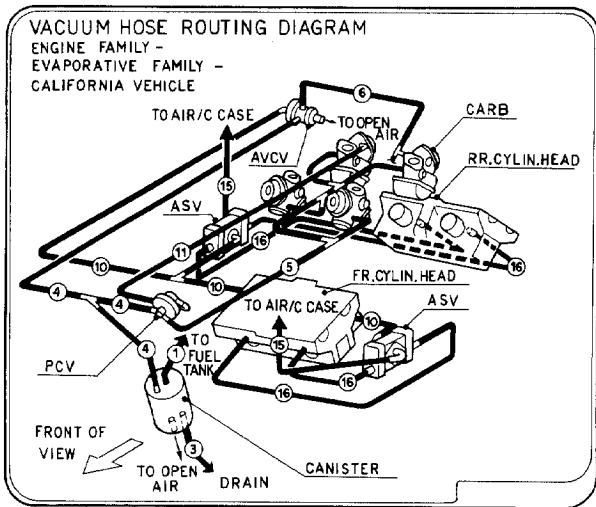

After '93:

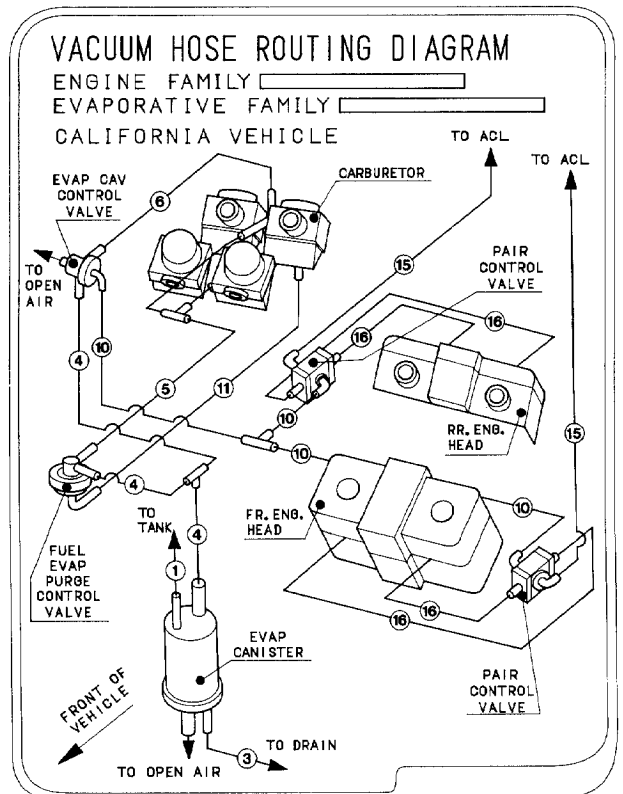

## 2. Body Panels/Exhaust System/Sub Frame

Service Information	2-1	Lower Center Fairing	2-8
Troubleshooting	2-1	Upper Fairing	2-10
Seat	2-2	Exhaust System	2-14
Rear Fairing	2-3	Sub Frame/Rear Fender	2-18
Middle Fairing	2-4	Fuel Tank	2-22
Lower Fairing	2-7		

### Service Information

- This section covers removal and installation of the body panels, exhaust system and sub frame.
- When removing a cover, be careful not to damage any tab or groove.

#### ⚠ WARNING

- Do not service the exhaust system while it is hot.

#### NOTE

- Replace the exhaust pipe gaskets if the exhaust system is removed.

- Generally speaking, plastic body panels cannot be repaired and therefore must be replaced.
- If the motorcycle has been involved in an accident, inspect the frame very carefully at the steering head and at the engine mounts. These are the areas most likely to suffer damage. It is possible to bend the frame steering head without bending the fork tubes or even the fork axle.

### Troubleshooting

- Failure of the front suspension, steering or rear suspension may damage the frame enough to require replacement.
- Refer to the Common Service Manual for front suspension and steering inspections.
- Refer to the Common Service Manual for rear suspension inspection.

#### Abnormal engine vibration

- Cracked or damaged engine mounts
- Cracked, damaged or bent welded portions
- Bent or damaged frame
- Engine problems

#### Abnormal noise when riding (banging or cracking)

- Damaged or bent engine mounts
- Damaged welded points
- Damaged or bent frame

#### Steers to one side when under acceleration or deceleration

- Bent frame
- Bent fork
- Bent swingarm

## Seat

'90-'93:

### Removal

Insert the ignition key into the seat lock/helmet holder. Turn the ignition key clockwise until it stops, pull the lever down then remove the seat by sliding it rearward.

### Installation

Apply grease to the hook of the seat. Install the seat fitting the hooks into each other.

#### NOTE

- Securely insert the prong on the front end of the seat into the recess on the fuel tank.

Push the seat down until it locks.

#### NOTE

- Make sure the seat is secured completely.

'90-'93:

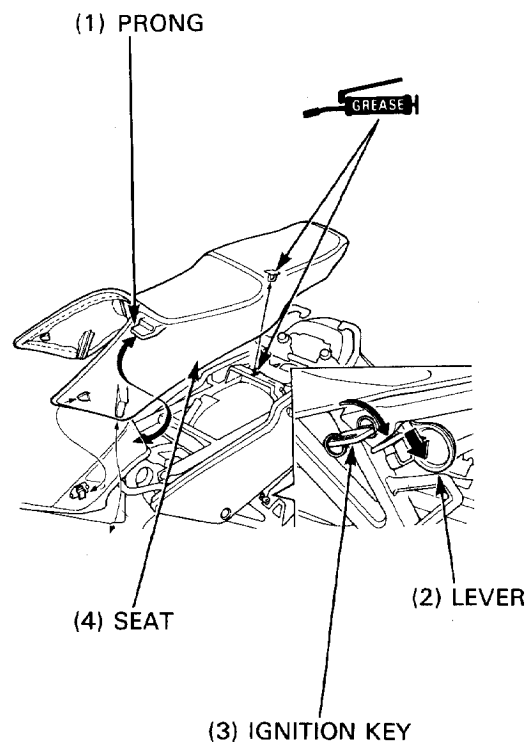

After '93:

### Removal

Insert the ignition key into the seat lock/helmet holder. Turn the ignition key clockwise until it stops, pull the lever down then remove the seat sliding backward.

### Installation

Apply grease to the hook of the seat. Install the seat fitting the hooks into each other. Push the seat down until it locks.

#### CAUTION

- After installation, make sure the seat is securely installed.

After '93:

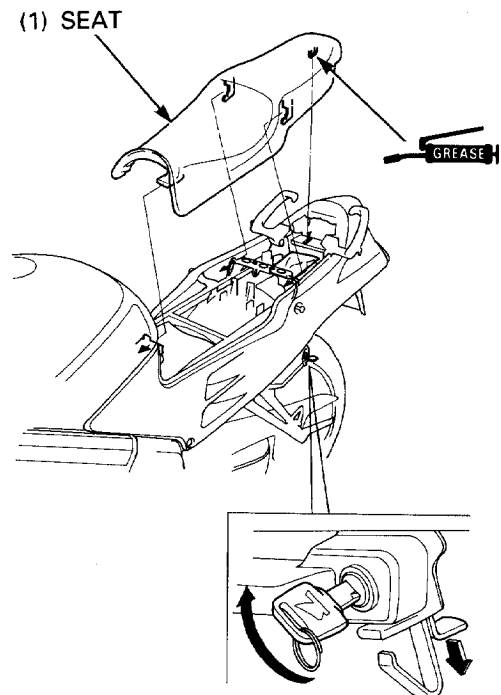

## Rear Fairing

'90-'93:

Remove the seat (page 2-2).

Disconnect the rear turn signal connectors and brake/taillight connector.

Remove the six bolts and unhook the tabs on the rear fairing from the frame.

Remove the rear fairing by sliding it rearward.

Install the rear fairing in the reverse order of removal.

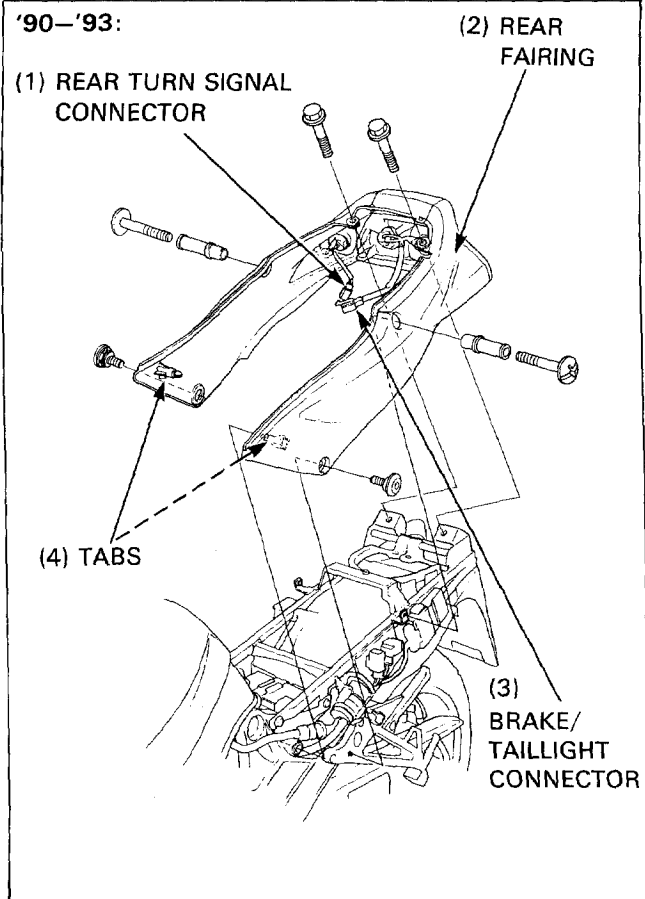

After '93:

Remove the seat (page 2-2).

Disconnect the rear turn signal & tail/brake light connector (6P White) inside the left side of the rear fairing.

Remove the grab rail bolts and washes, slide the grab rails inward and remove them from the frame pipes.

Remove the screws and distance collars.

Remove the socket bolts.

Release the fairing bosses from the grommets.

Remove the fairing rearward while carefully spreading open the front end.

### CAUTION

- Be careful not to damage the fairing.

Installation is in the reverse order of removal.

### TORQUE:

Rear grab rail bolt: 35 N·m (3.5 kg·m, 25 ft·lb)

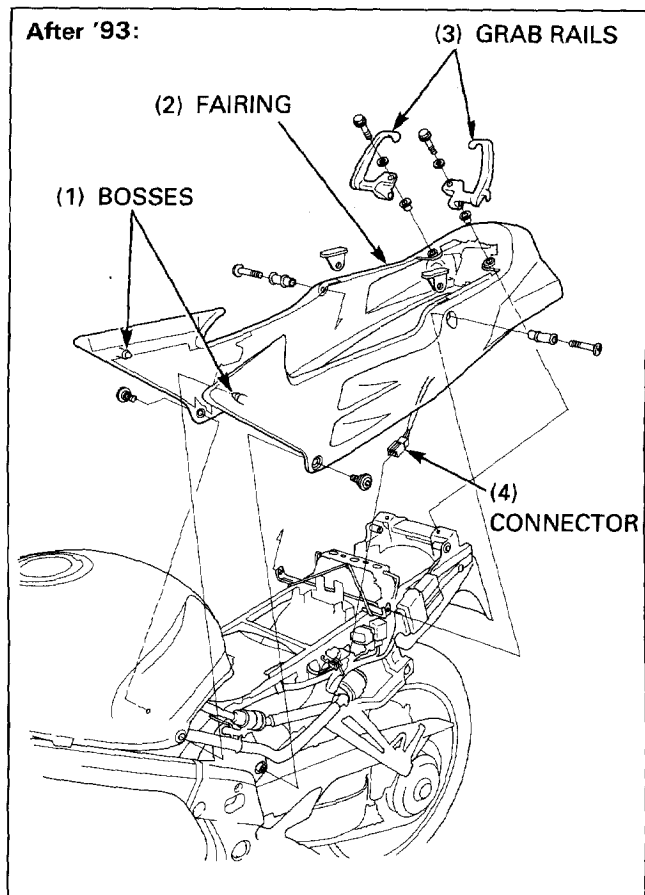

Disassemble the rear fairing as shown.

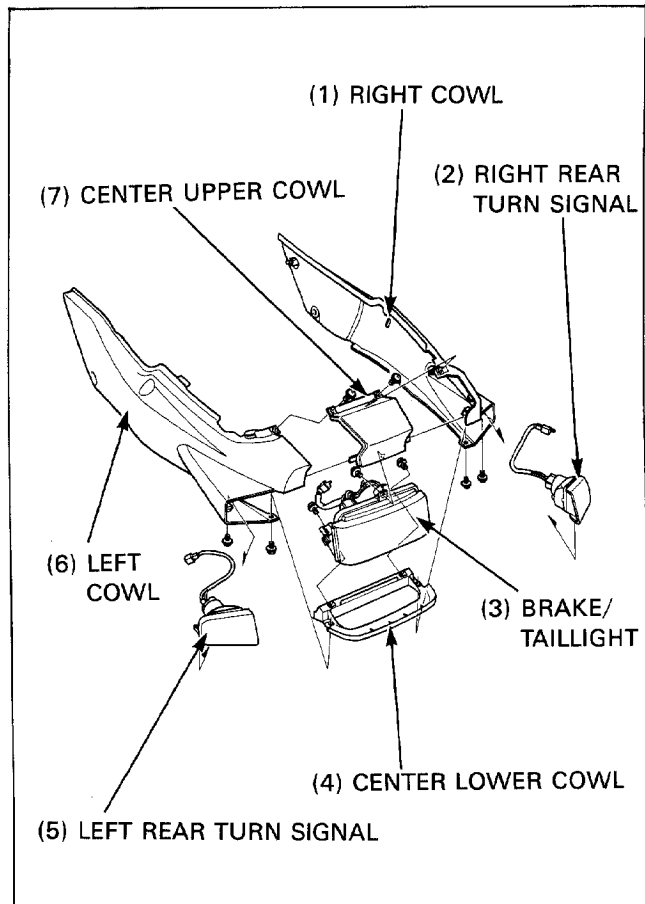

## Middle Fairing

'90-'93:

### Removal

Turn the quick screws 90 degrees counterclockwise.

Remove the front lower screw.

### CAUTION

- Before removing the middle fairing, remove the front lower screw securely.  
If the front lower screw stays in the middle fairing, middle fairing will damage.

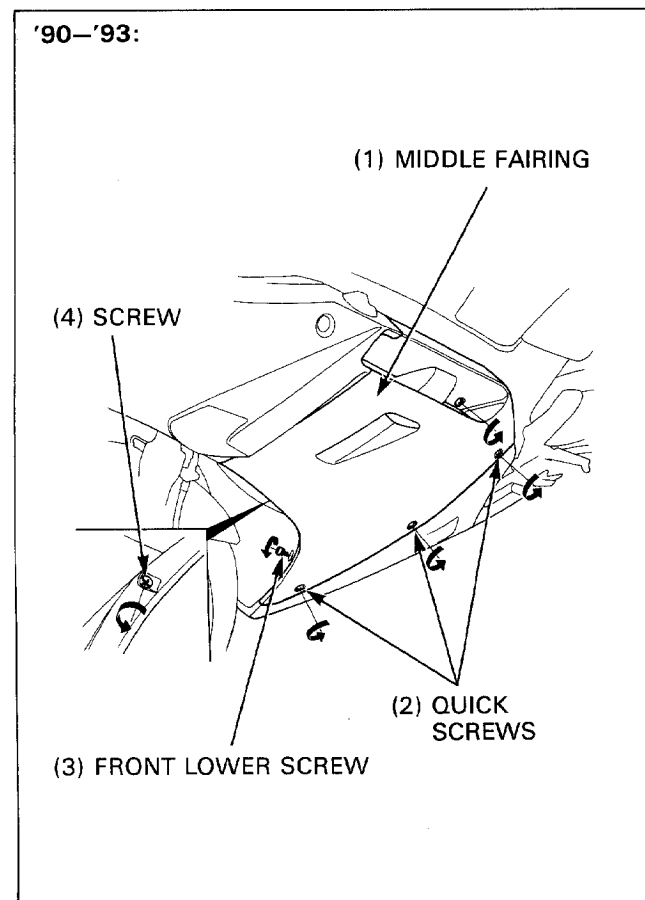

Pull the middle fairing out and down until the tabs can be removed from the grooves in the upper fairing.

**CAUTION**

- Do not damage the middle fairing tabs and upper fairing grooves.

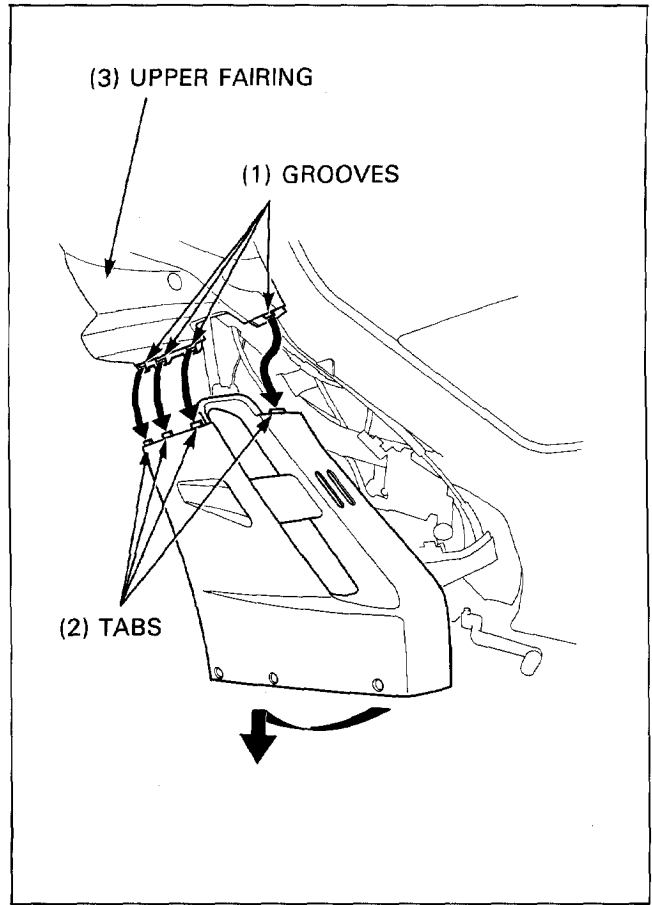

**Installation**

Install tabs ① through ③ the left middle fairing into the left upper fairing by placing area A underneath area C.

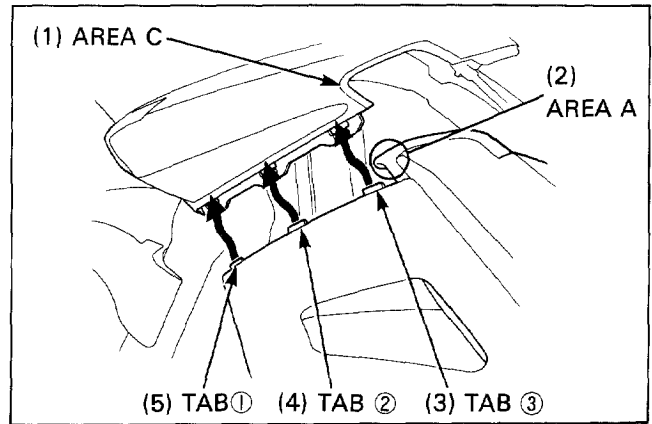

Gently press the lower portion of the left middle fairing in the direction shown by the arrow so that area B is underneath area D.

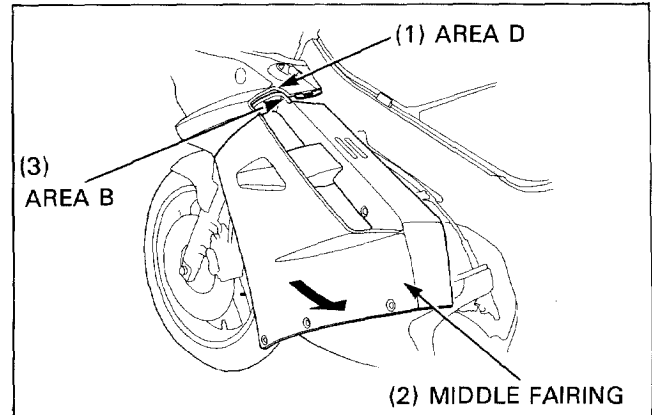

Install the tab ④ into the upper fairing groove while pressing area E.

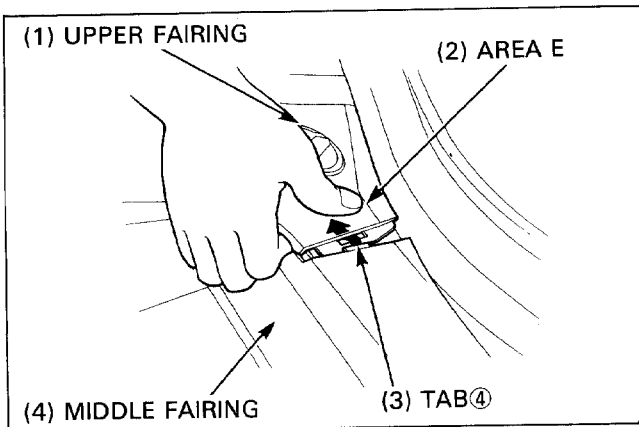

Install the front lower screw.  
Tighten the quick screws.

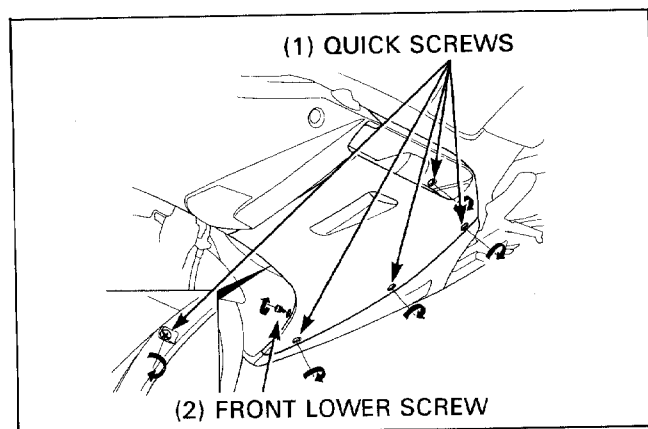

**After '93:**

### Removal

Turn the five quick screws counterclockwise 90°. Remove the socket bolt.

Release the front lower edge of the middle fairing from the lower fairing and the tab of the upper fairing from the middle fairing groove.

Raise the lower end of the middle fairing outward by supporting the upper mounting portion (upper tabs) until the upper tabs can be released from the upper fairing slits.

Remove the middle fairing downward.

### CAUTION

• Be careful not to break the fairing tabs.

### Installation

Insert the upper tabs into the slits of the upper fairing and align the groove with the tab of the upper fairing. Carefully press the lower portion of the middle fairing. Make sure the front lower edge and front tabs securely installed.

Tighten the quick screws and socket bolt securely.

**After '93:**

(1) GROOVE AND TAB

(2) TABS AND SLITS

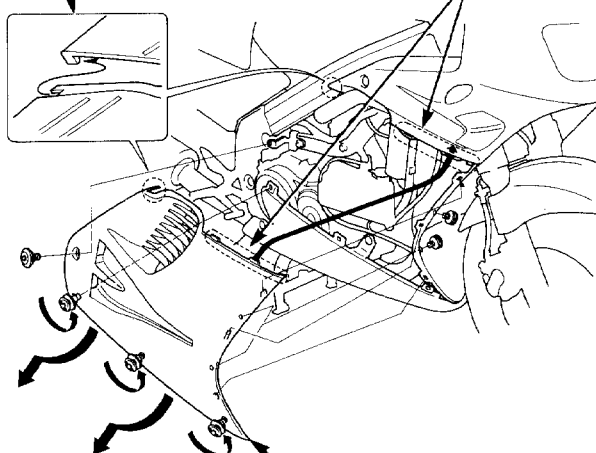
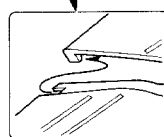

(3) EDGE

## Lower Fairing

'90-'93:

Remove the middle fairings (page 2-4).  
Remove the socket bolts and trim clips, and remove the lower fairing.

### CAUTION

- Do not damage the fairing surface when removing the fairing.

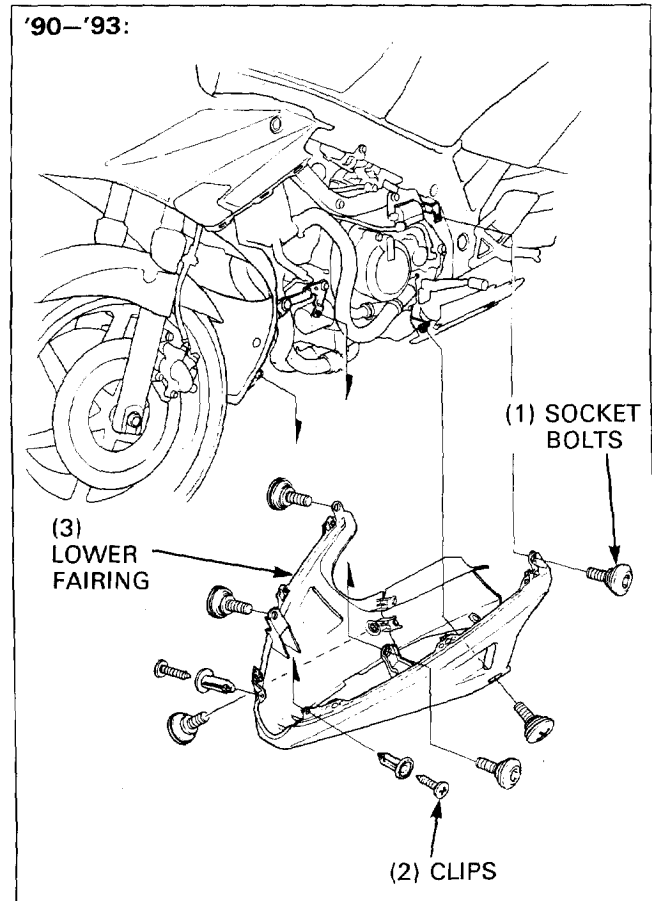

After '93:

Remove the middle fairings (page 2-6).  
Remove the four socket bolts and lower fairing.  
Installation is in the reverse order of removal.

### NOTE

- Align the tabs with the tabs of lower center fairing as shown.

### CAUTION

- Be careful not to bend the lower fairing stays when tightening the front bolts.

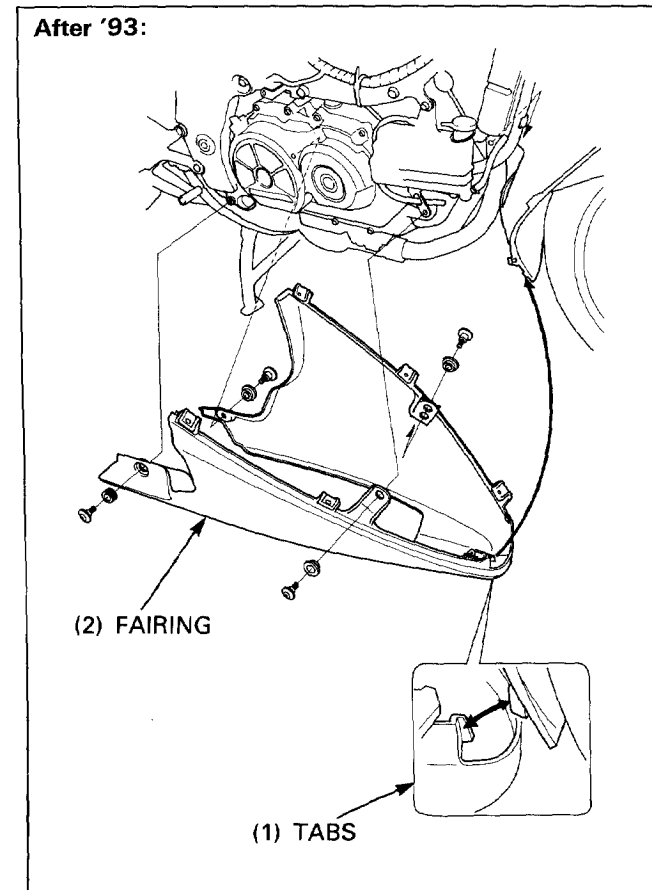

## Lower Center Fairing

'90:

Remove the middle fairing and lower fairing (page 2-4 and 2-7).

Remove the socket bolts.

Release the trim clips by turning center pin with a screw driver and remove the trim clips.

Remove the lower center fairing.

### CAUTION

- Be careful not to damage the fairing.

Installation is in the reverse order of removal.

### NOTE

- When installing the trim clips, lock by pushing the center pin flush.

'90:

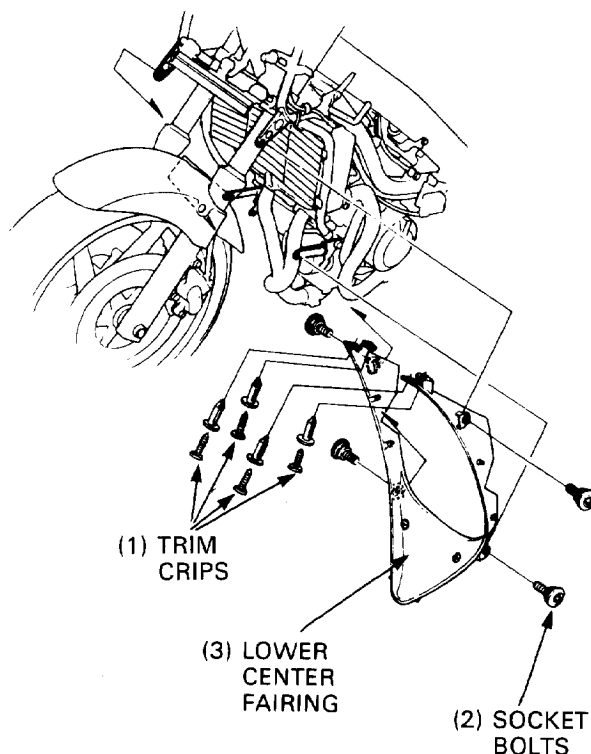

'91-'93:

Remove the middle fairing and lower fairing (page 2-4 and 2-7).

Remove the following:

- Trim clips (see above)
- Self-Tapping screws
- Grommets
- Packings
- Lower center fairing

### CAUTION

- Be careful not to damage the fairing.

Installation is in the reverse order of removal.

'91-'93:

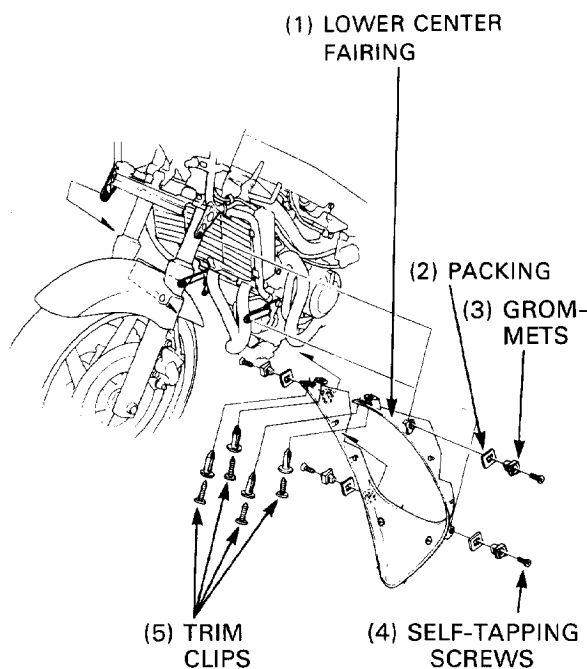

**After '93:**

Remove the middle fairings (page 2-6).

Remove the two trim clips and upper fairing lower cover. Remove the four trim clips (see blow) and lower center fairing.

Installation is in the reverse order of removal.

**NOTE**

- Align the tabs with the tabs of lower center fairing as shown.

**After '93:**

(1) LOWER COVER

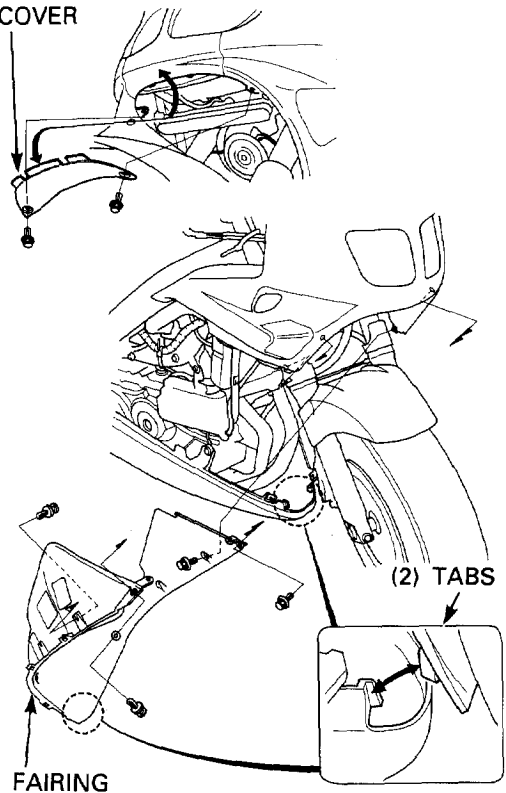

**Trim Clip Removal/Installation (After '93)**

**Removal**

- ① Release by pushing the center pin.
- ② Remove the clip.

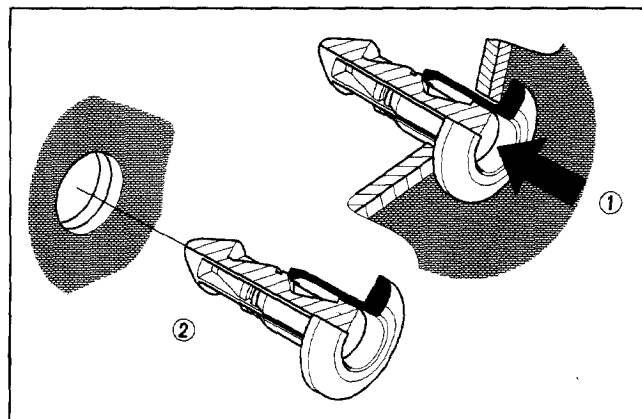

**Installation**

Raise the center pin by pushing the pin tip back.

- ③ Install the clip.
- ④ Lock by pushing the center pin flush.

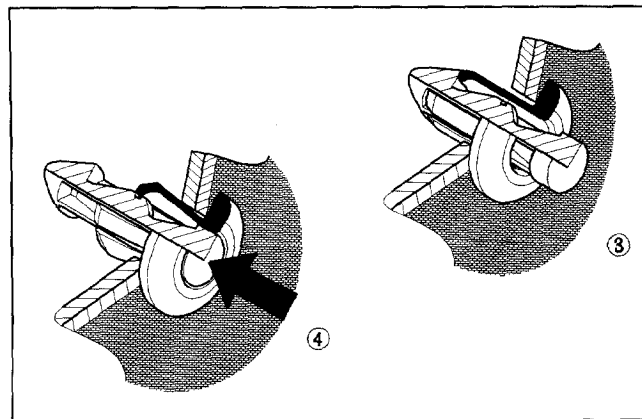

# Upper Fairing

'90-'93:

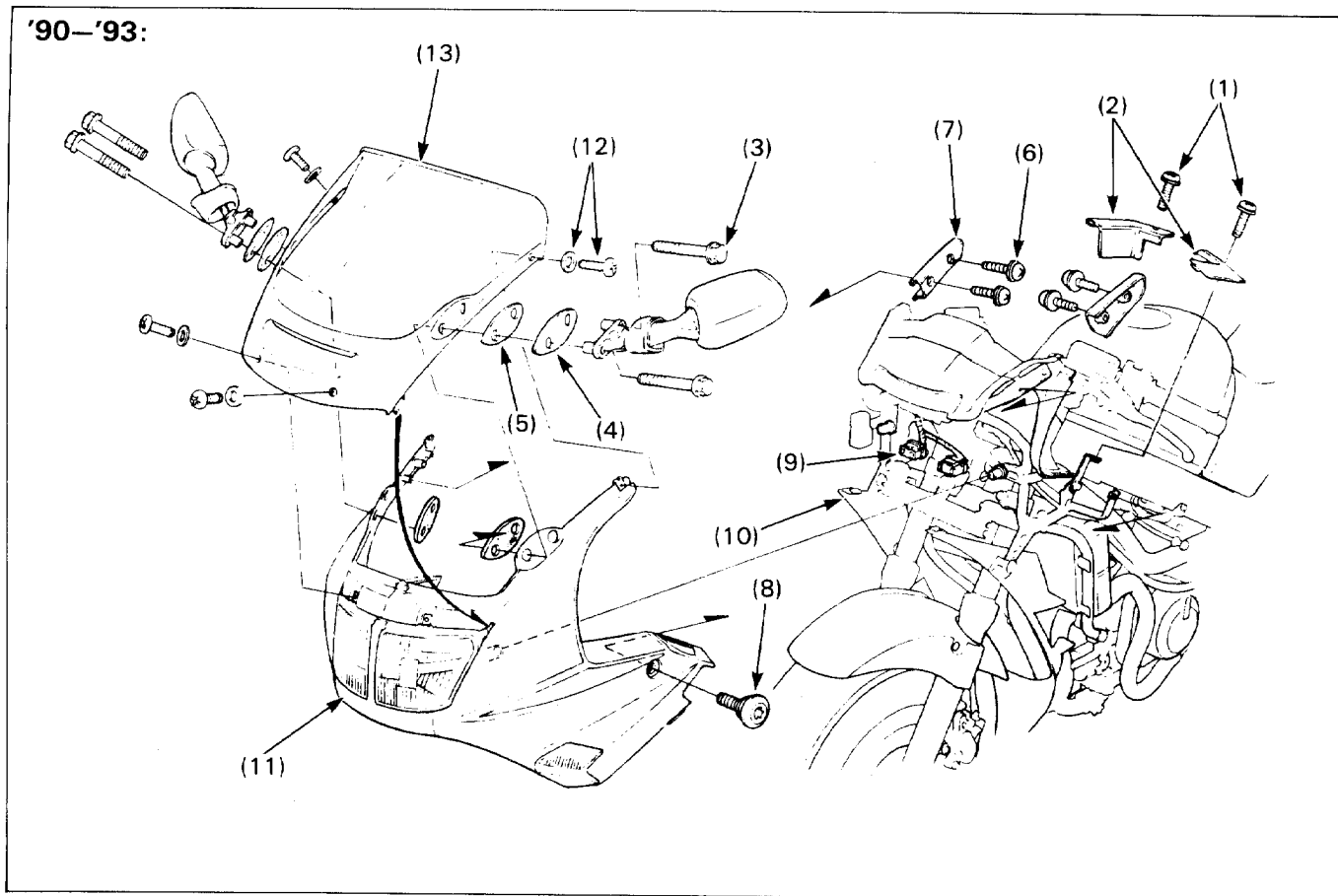

## Requisite Service

- Remove the middle fairing (page 2-4).
- Support the motorcycle by placing a support block under the engine.

Procedure	Q'ty	Remarks
<b>Removal Order</b>		• Installation is in the reverse order of removal.
(1) Fairing inner cover screw	2	
(2) Fairing inner cover	1	
(3) Rear view mirror bolt	4	
(4) Plate	2	
(5) Rubber	2	
(6) Socket bolt	4	
(7) Inner cover	2	
(8) Upper fairing socket bolt	2	
(9) Headlight connector	1	
(10) Front turn signal connector	2	
(11) Upper fairing	1	
(12) Windshield screw washer	1/1	
(13) Windshield	1	



After '93:

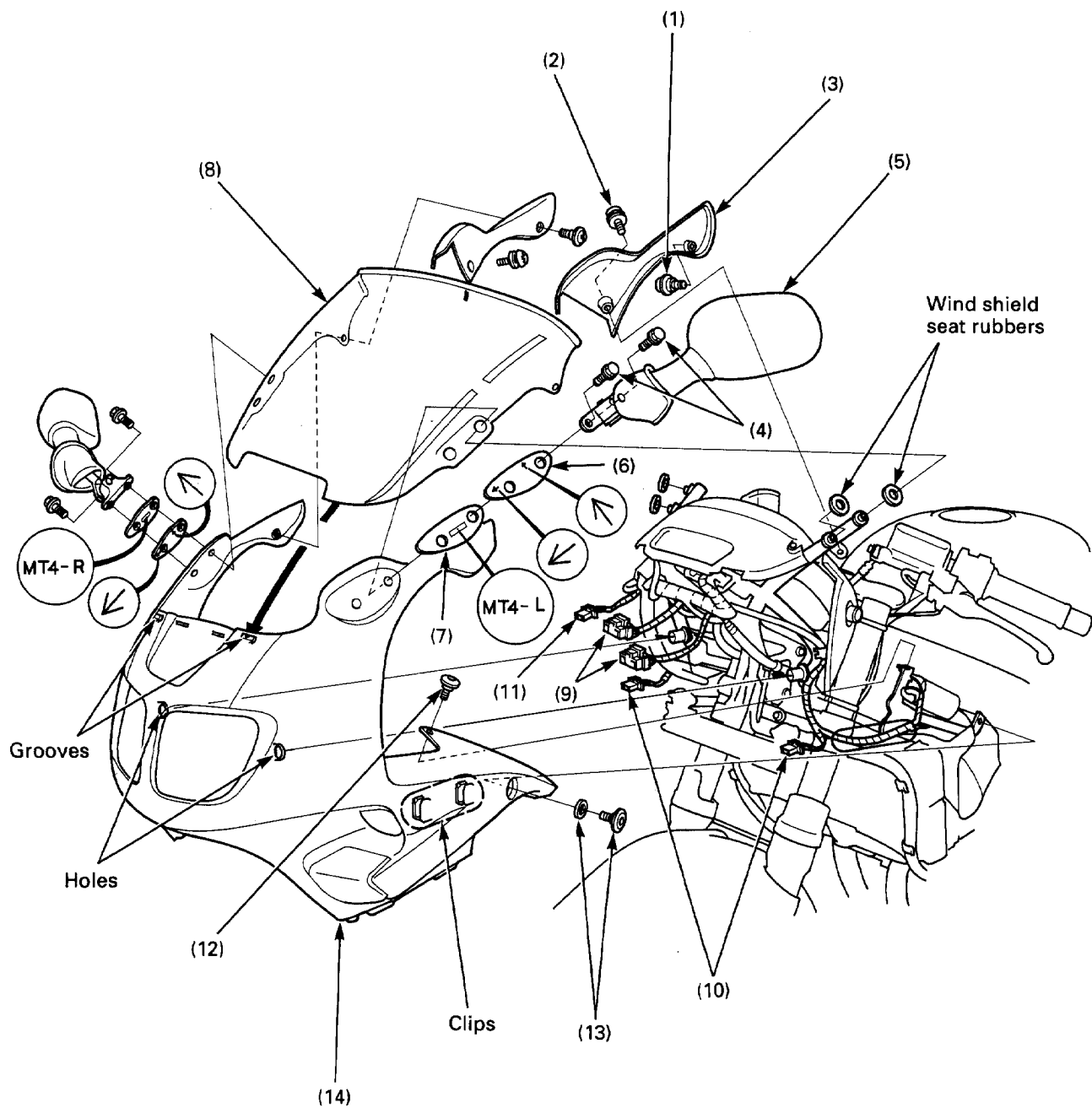

## Requisite Service

- Lower center fairing removal/installation (page 2-9)

Procedure		Q'ty	Remarks
<b>Removal Order</b> <b>Wind shield:</b> (1) Flange screw (2) Washer screw (3) Rear view mirror inner cover (4) Bolt (5) Rear view mirror (6) Mirror plate  (7) Seat rubber  (8) Wind shield		 2 2 2 4 2 2  2  1	Installation is in the reverse order of removal.  NOTE • Install the right plate with the marked side facing in and the left plate with the marked side facing out, and each arrow marks pointing forward and up. NOTE • Install the right rubber seat with the "R" mark facing in and the left rubber seat with the "L" mark facing out. NOTE • Remove from the fairing stay bosses while carefully spreading open the rear end of the upper fairing. <b>CAUTION</b> • <b>Be careful not to damage or scratch the shield.</b> NOTE • Before installation, make sure the four seat rubbers onto the fairing stay bosses. • At installation, align the front end with the grooves in the upper fairing.
<b>Upper fairing:</b> (9) Headlight socket (10) Turn signal connector  (11) Position light connector (12) Socket bolt (13) Socket bolt/grommet (14) Upper fairing		 2 2  1 2 2/2 1	Release the wire from the clips on the reverse side of the left air intake duct.  NOTE • At installation, align holes in the headlight with the mounting bosses of the fairing stay.

# Exhaust System

'90-'93:

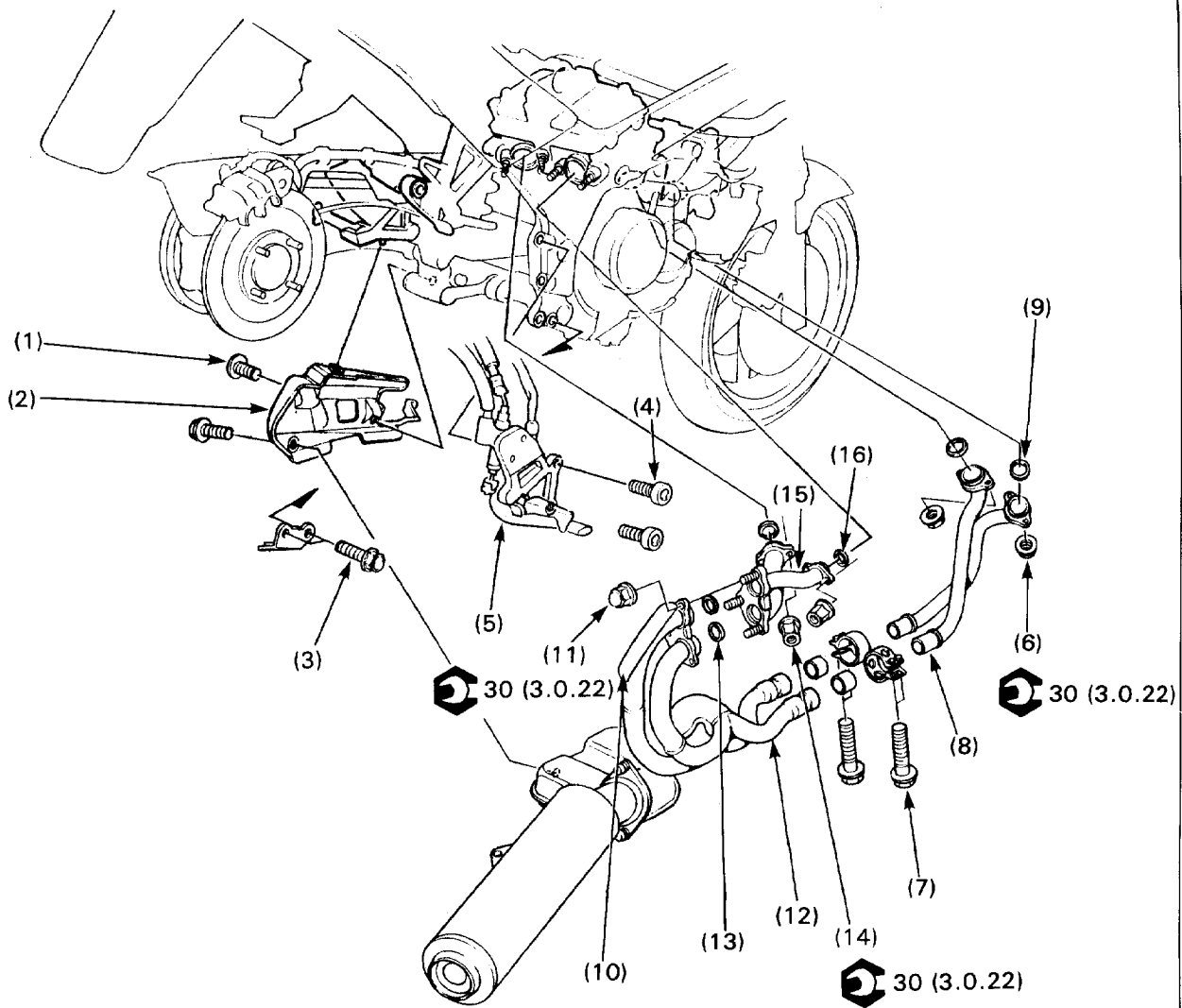

**⚠ WARNING**

- Do not service the exhaust system while it is hot.

**NOTE**

- Replace the exhaust pipe gaskets if the exhaust system is removed.

**Requisite Service**

- Support the motorcycle using a hoist.
- Remove the rear wheel (page 13-2).

Procedure		Q'ty	Remarks
<b>Removal Order</b>			• Installation is in the reverse order of removal.
(1)	Lower cover bolt	3	
(2)	Lower cover	1	
(3)	Bolt	4	
(4)	Footpeg bracket bolt	2	
(5)	Footpeg bracket	1	
(6)	Front exhaust joint nut	4	
(7)	Exhaust pipe band bolt	2	Not necessary to remove, just loose.
(8)	Front exhaust pipe	1	
(9)	Gasket	2	
(10)	Muffler protector	1	
(11)	Exhaust chamber joint nut	3	
(12)	Exhaust chamber	1	
(13)	Gasket	2	
(14)	Rear exhaust pipe joint nut	4	
(15)	Rear exhaust pipe	1	
(16)	Gasket	2	
<b>Installation order</b>			
(16)	Gasket	2	
(15)	Rear exhaust pipe	1	
(14)	Rear exhaust pipe joint nut	4	Tighten to the specified torque.
(13)	Gasket	2	
(12)	Exhaust chamber	1	
(11)	Exhaust chamber joint nut	3	Install but do not tighten yet.
(10)	Muffler protector	1	
(9)	Gasket	2	
(8)	Front exhaust pipe	1	
(7)	Exhaust pipe band bolt	2	Install but do not tighten yet.
(6)	Front exhaust joint nut	4	After installing, tighten the following in sequence. ①Exhaust pipe band bolt (7) ②Exhaust chamber joint nut (11) ③Front exhaust joint nut (6)
(5)	Footpeg bracket	1	
(4)	Footpeg bracket bolt	2	
(3)	Bolt	4	
(2)	Lower cover	1	
(1)	Lower cover bolt	3	

After '93:

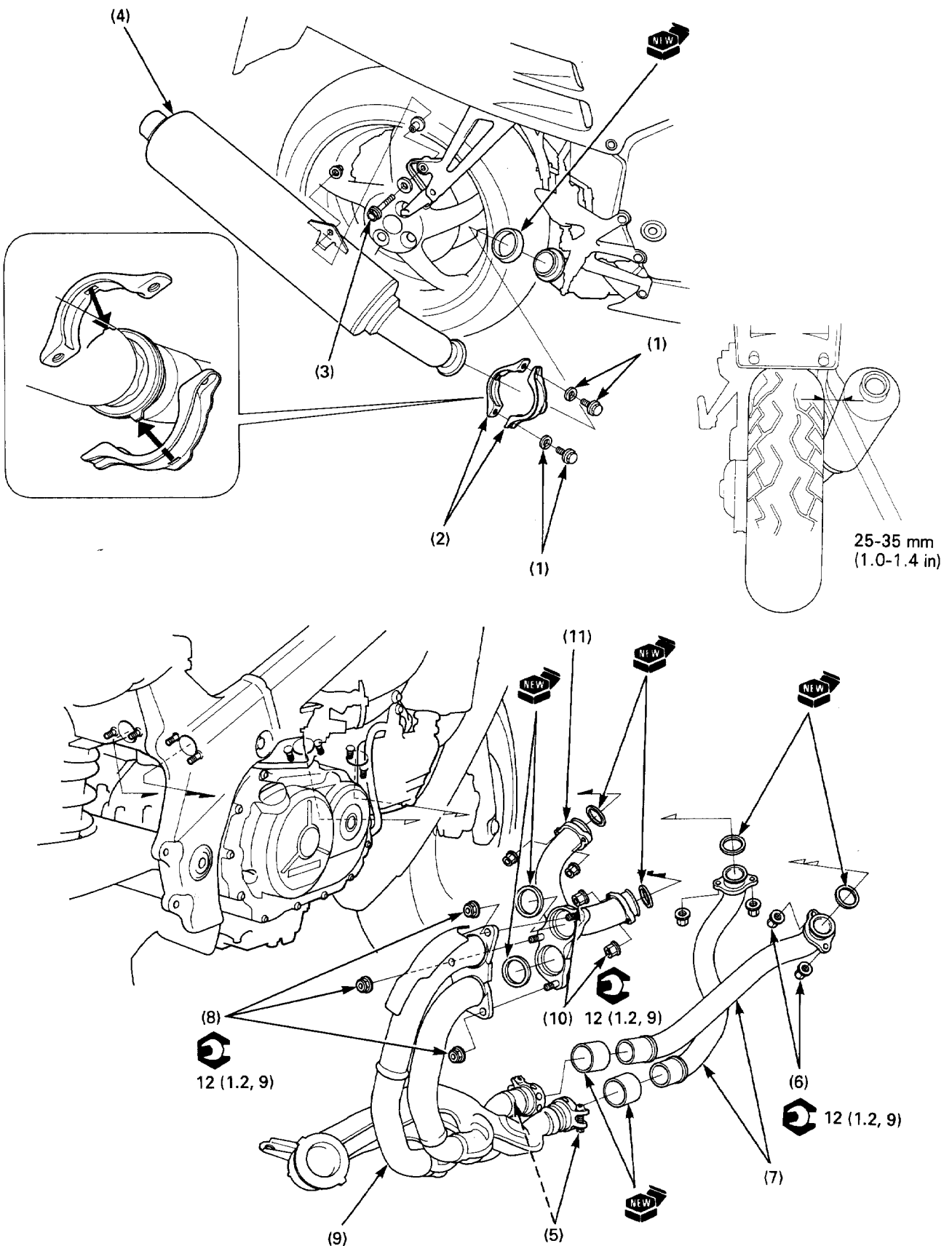

**▲ WARNING**

• Do not service the exhaust system while it is hot.

**NOTE**

- If you plan to remove the muffler only, it is not necessary to remove the centerstand, lower fairing and footpeg holder.
- When fitting the muffler, allow a distance of 25–35 mm (1.0–1.4 in) between the muffler and the rear tire as shown.

**Requisite Service**

- Center stand removal/installation (page 13-16)
- Right footpeg stay removal/installation (page 14-12)
- Lower fairing removal/installation (page 2-7)

Procedure		Q'ty	Remarks
<b>Removal Order</b>			Installation is in the reverse order of removal.
<b>Muffler:</b>			
(1)	Muffler joint bolt/washer	2/2	At installation, align the clamp slits with the chamber tabs.
(2)	Muffle clamp	2	
(3)	Muffler mounting bolt	1	
(4)	Muffler	1	
<b>Exhaust Pipe/Chamber:</b>			
(5)	Exhaust pipe band bolt	2	Only loosen. <b>NOTE</b> • First install all the fasteners loosely. Next, tighten the joint nuts then tighten the band bolts.
(6)	Front exhaust pipe joint nut	4	
(7)	Front exhaust pipe	2	
(8)	Chamber joint nut	3	
(9)	Chamber	1	
(10)	Rear exhaust pipe joint nut	4	
(11)	Rear exhaust pipe	1	

# Sub Frame/ Rear Fender

'90-'93:



22 (2.2, 16)



45 (4.5, 33)

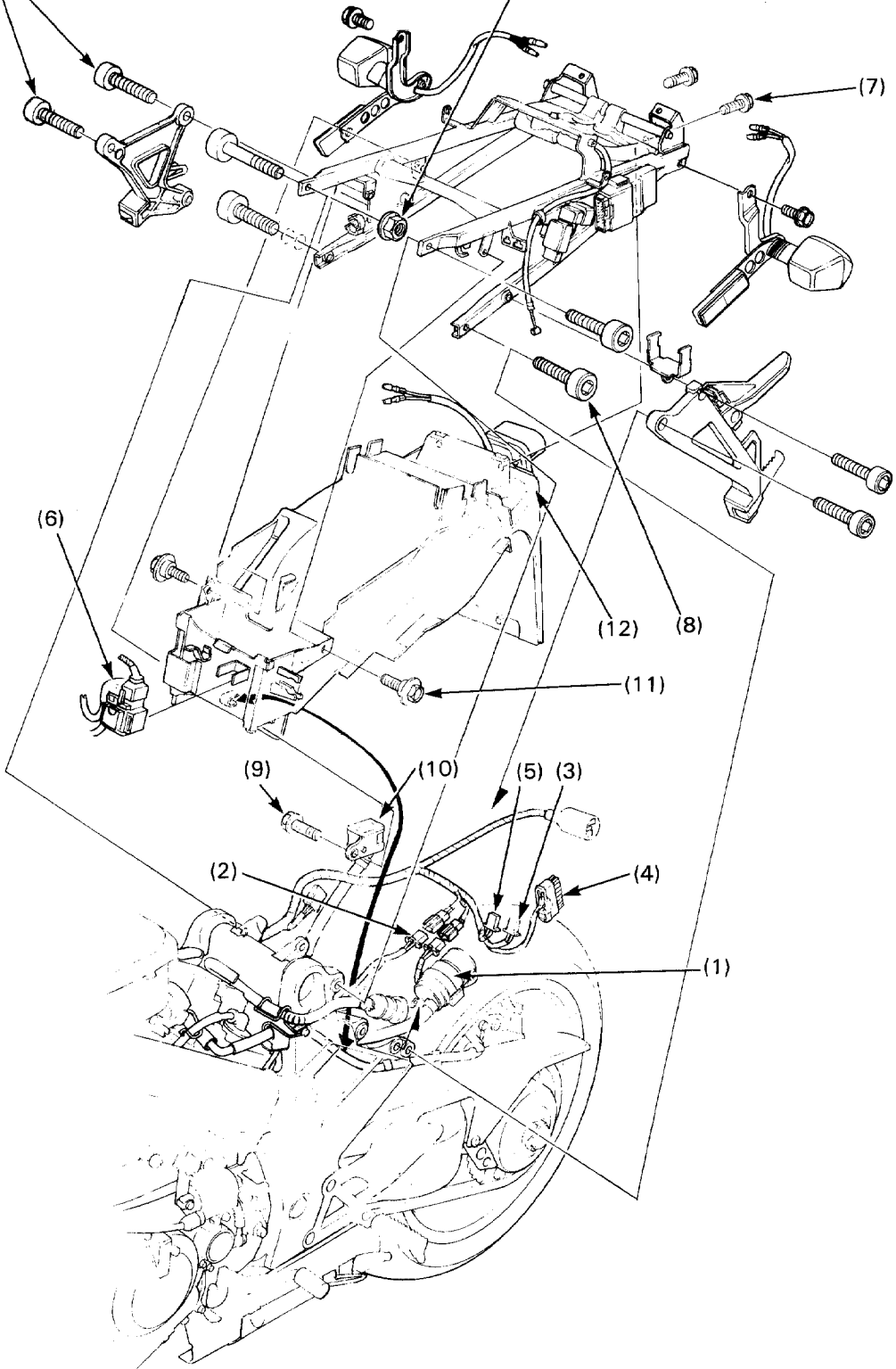

**Requisite Service**

- Remove the seat (page 2-2) and rear fairing (page 2-3).

Procedure		Q'ty	Remarks
	<b>Removal Order</b>		<ul style="list-style-type: none"> <li>• Installation is in the reverse order of removal.</li> <li>Disconnect the connector.</li> </ul>
(1)	Fuel pump	1	
(2)	Side stand switch connector	1	
(3)	Turn signal relay connector	1	
(4)	Spark unit connector	1	
(5)	Fuel cut off relay connector	1	
(6)	Starter switch	1	
(7)	Rear frame bolt	4	
(8)	Rear frame socket bolt	2	
(9)	Rear master cylinder reservoir bolt	1	
(10)	Rear master cylinder reservoir	1	
(11)	Rear fender bolt	2	
(12)	Rear fender	1	

After '93:

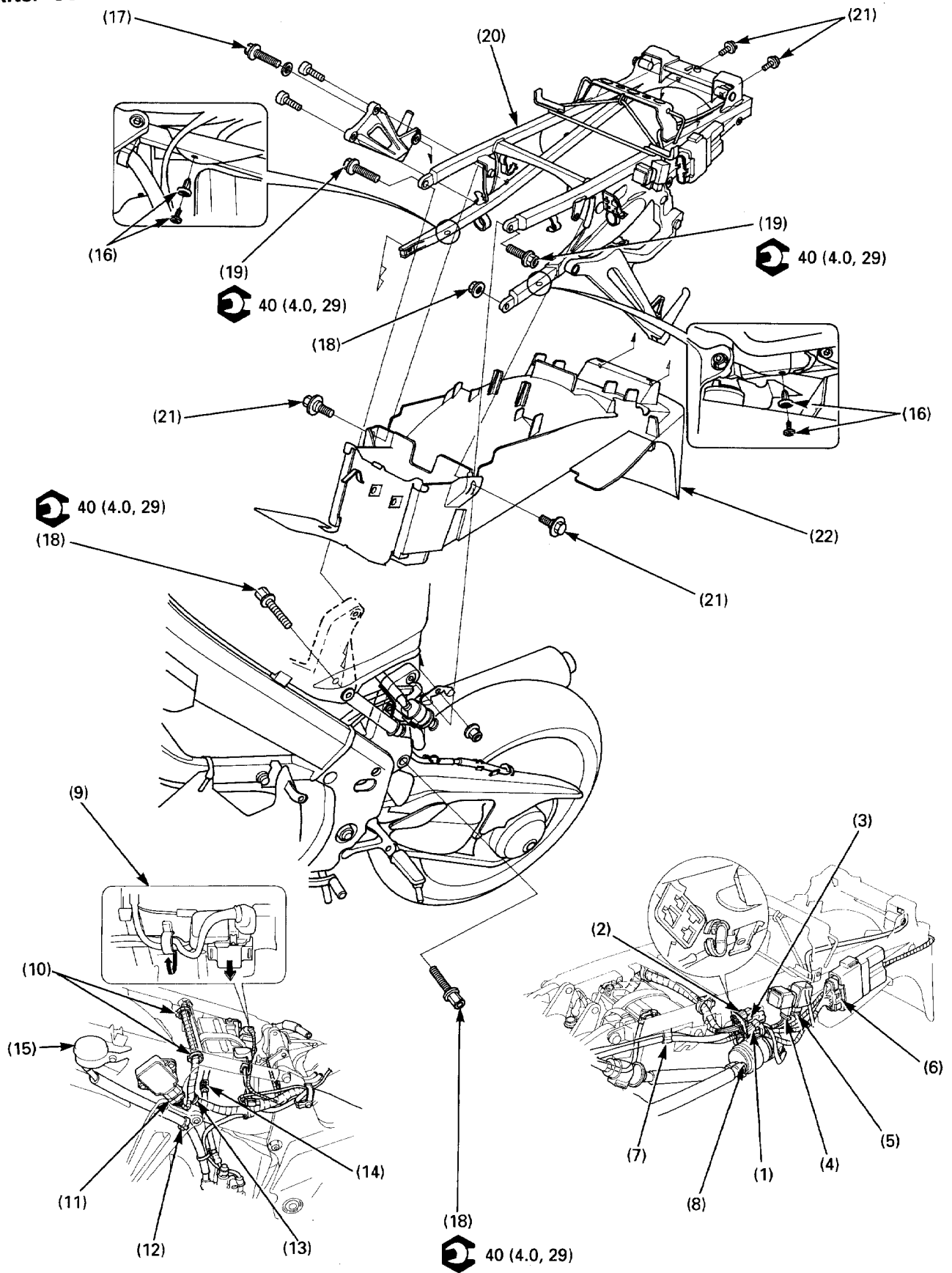

**Requisite Service**

• Rear fairing removal/installation (page 2-3)

• Battery removal/installation (page 15-4)

Procedure	Q'ty	Remarks
<b>Removal Order</b>		Installation is in the reverse order of removal.
(1) Speed sensor connector (3P White)	1	
(2) Fuel pump connector (2P Red)	1	
(3) Side stand switch connector (3P Green)	1	
(4) Fuel cut-off relay connector	1	
(5) Turn signal relay connector	1	
(6) Ignition control module connector	1	
(7) Speed sensor/side stand switch wire	1/1	Release from the clip.
(8) Fuel pump	1	Remove from the sub frame stays.
(9) Starter relay switch	1	Remove from the stays and release the wire harness from the clamp.
(10) Wire harness	1	Release from the clips.
(11) Regulator/rectifier connector	1	
(12) Brake reservoir hose	1	Release from the clip.
(13) Wire harness	1	
(14) Brake hose	1	Release from the clamp.
(15) Rear master cylinder reservoir	1	NOTE • Keep the reservoir upright to prevent air from entering the hydraulic system.
(16) Trim clip	2	
(17) Muffler mounting bolt	1	
(18) Sub frame bolt/nut (lower)	2/1	
(19) Sub frame bolt (upper)	2	
(20) Sub frame assembly	1	
(21) Fender bolt	4	
(22) Rear fender	1	

## Fuel Tank

'90-'93:

### ▲ WARNING

- Gasoline is extremely flammable and is explosive under certain conditions.
- Work in a well ventilated area. Smoking or allowing flames or sparks in the work area or where gasoline is stored can cause a fire or explosion.

### Removal

Remove the seat (page 2-2).  
Turn the fuel valve OFF.

Remove the fuel tank mounting bolt and lift the tank up. Disconnect the fuel sensor connector and fuel tube. Drain the gasoline in the fuel tube into an approved gasoline container.

Unhook the fuel tank and remove it.

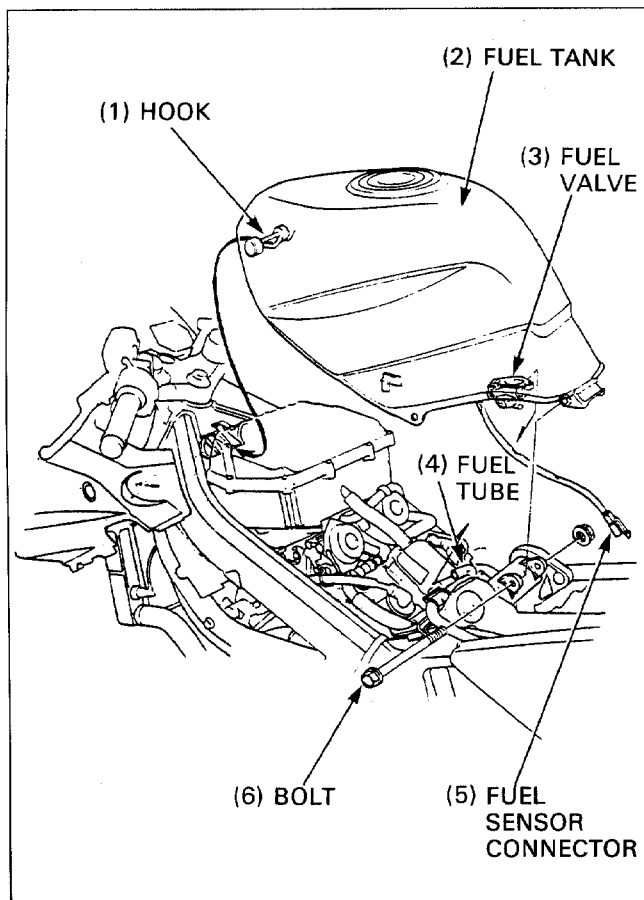

### Installation

Install the fuel tank on the frame then secure it with the bolt and nut.

### CAUTION

- Install the fuel tube securely on to the guide (2). Do not bent or twist the fuel tube.

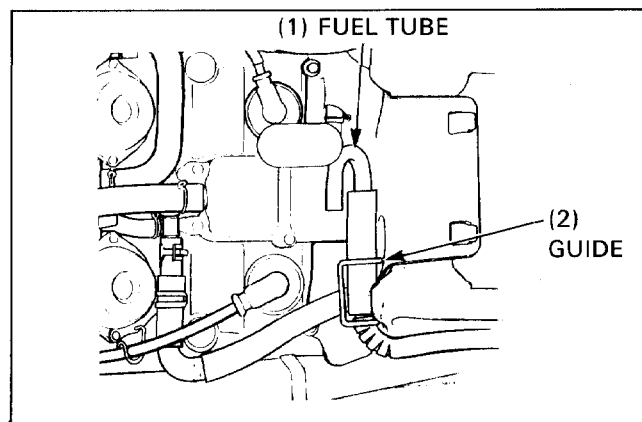

### NOTE

- Be sure to turn the fuel valve to ON after installing the fuel tank.

Install the seat (page 2-2).

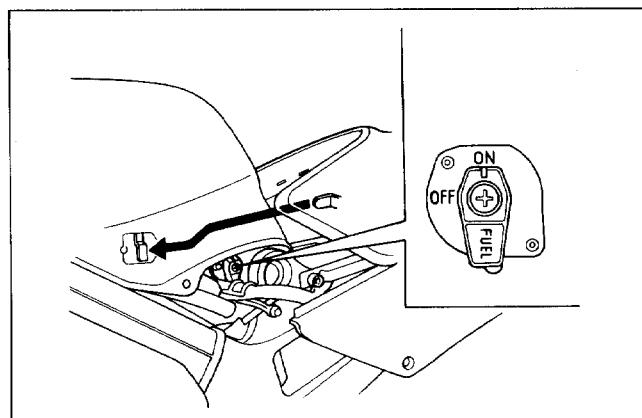

After '93:

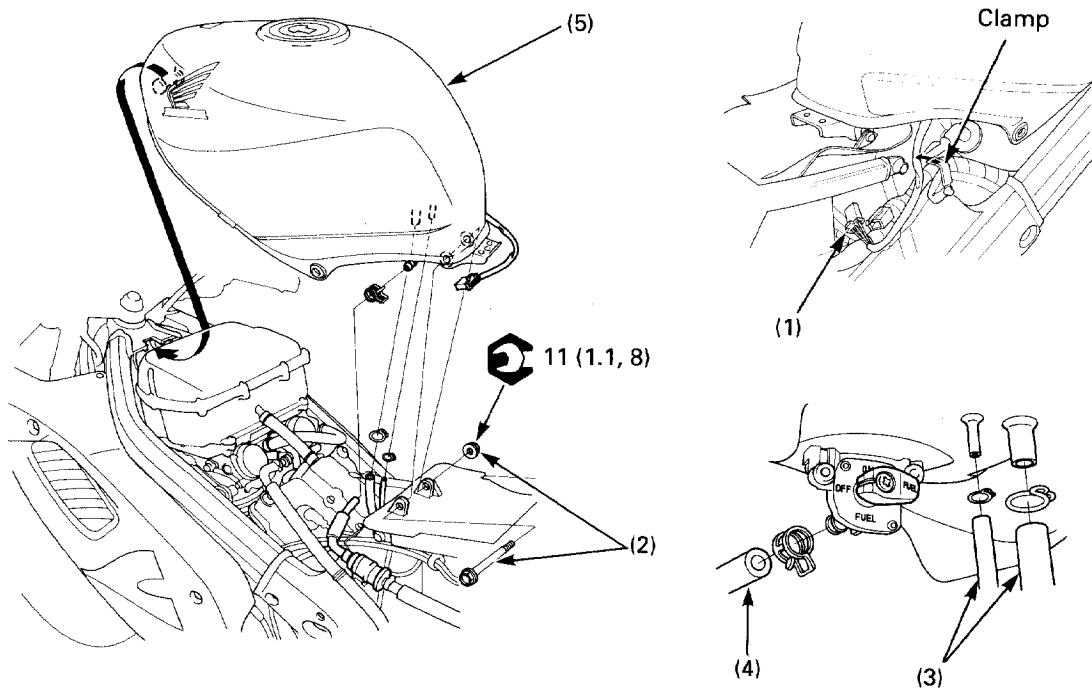

**WARNING**

- Gasoline is extremely flammable and is explosive under certain conditions. KEEP OUT OF REACH OF CHILDREN.
- Work in a well-ventilated area. Smoking or allowing flames or sparks in the work area or where gasoline is stored can cause a fire or explosion.

**NOTE**

- Before removal, turn the fuel valve OFF.
- After installation, check the fuel line for leakage.

**Requisite Service**

- Rear fairing removal/installation (page 2-3)

Procedure	Q'ty	Remarks
<b>Removal Order</b>		
(1) Fuel level sensor connector	1	Installation is in the reverse order of removal. Release the level sensor wire from the clamp.  Raise the rear of the fuel tank by supporting the front mounting portion of the tank and disconnect the tubes. Slide the fuel tank rearward and remove it. <b>NOTE</b> • Do not damage the tank mounting grommets when installing the tank.
(2) Bolt/nut	1/1	
(3) Drain/breather tube (California: No.1 tube)	1/1	
(4) Fuel tube	1	
(5) Fuel tank	1	



# 3. Maintenance

<b>Service Information</b>	<b>3-1</b>	<b>Valve Clearance</b>	<b>3-7</b>
<b>Service Access Guide</b>	<b>3-2</b>	<b>Carburetor Synchronization</b>	<b>3-11</b>
<b>Maintenance Schedule</b>	<b>3-4</b>	<b>Drive Chain</b>	<b>3-12</b>
<b>Air Cleaner</b>	<b>3-6</b>	<b>Headlight Aim</b>	<b>3-15</b>
<b>Spark Plug</b>	<b>3-7</b>	<b>Side Stand</b>	<b>3-15</b>

## Service Information

- Refer to the Common Service Manual for items not included in this manual.
- Refer to the specifications (Section 1) for maintenance service data.

# Service Access Guide

- The following shows the locations of the maintenance items listed below and the parts required to be removed for that maintenance service. Refer to the Common Service Manual for items not covered in this manual.
- Refer to section 2 (Body panels/Exhaust system/Sub frame), for the parts required to be removed for service. For example: AIR CLEANER (Contamination, clogging, replacement)——maintenance parts (service item)

'90-'93 shown:

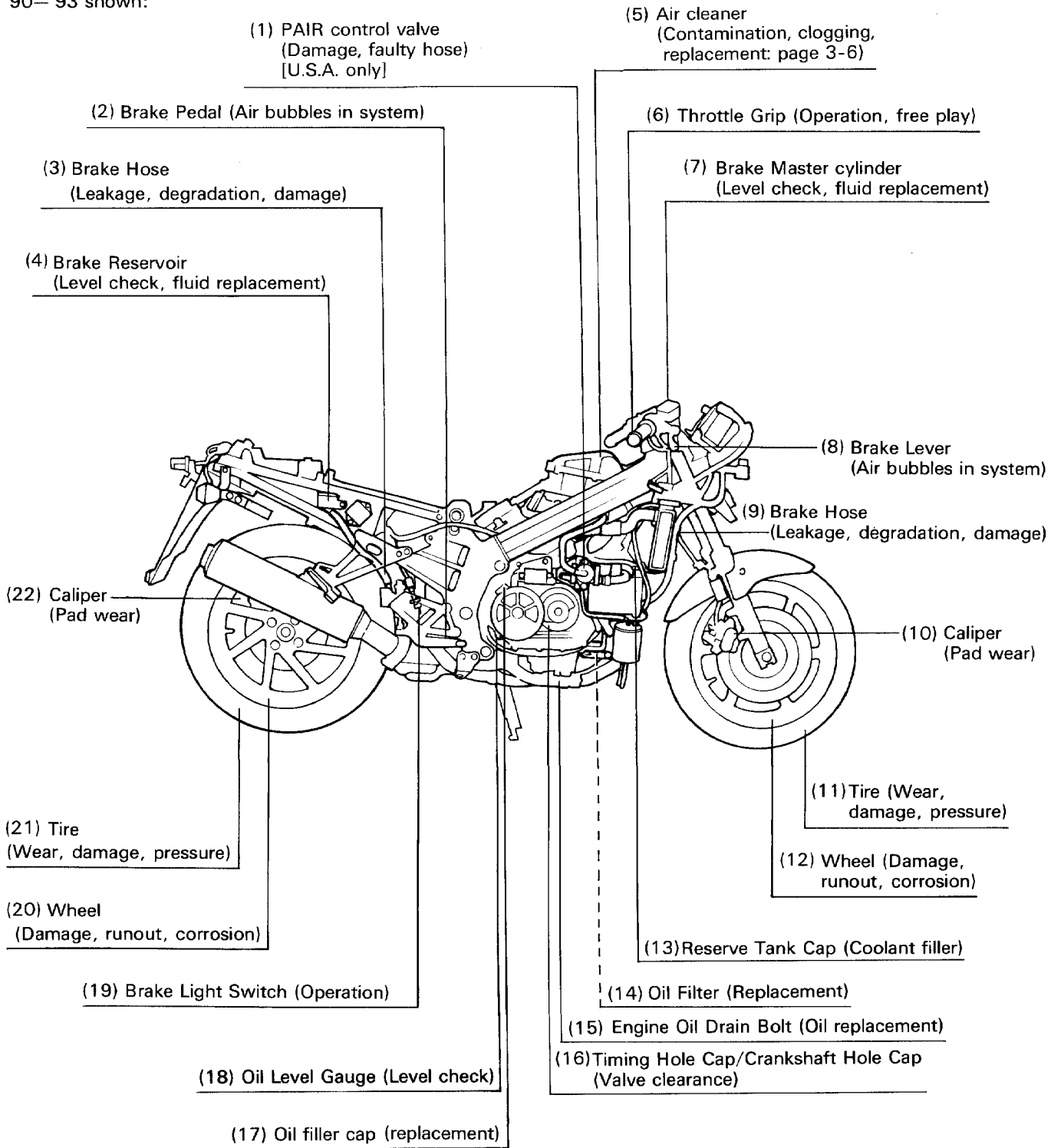

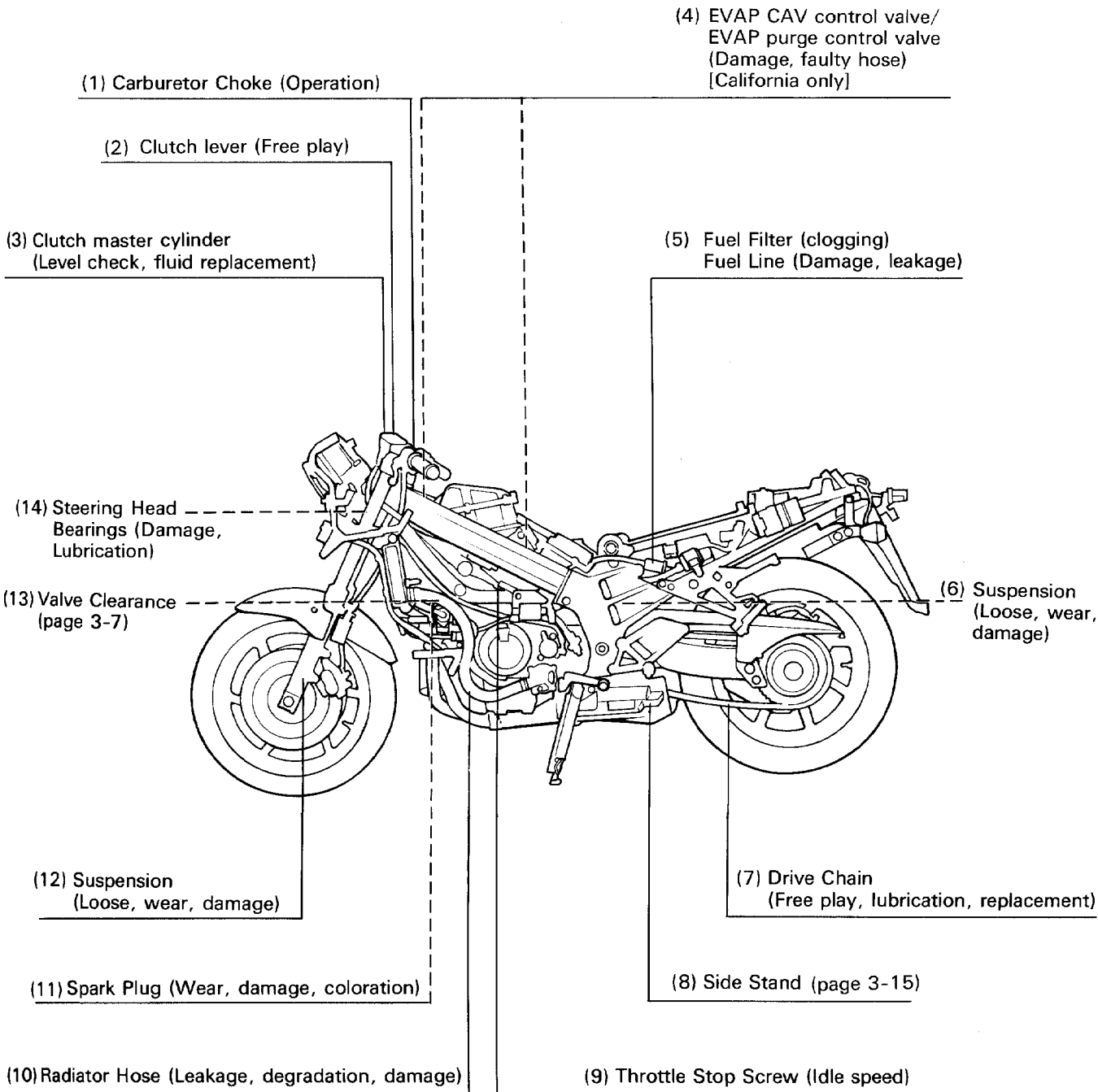

# Maintenance Schedule

'90-'93:

Perform the PRE-RIDE INSPECTION in the Owner's Manual at each scheduled maintenance period.

I: Inspect and Clean, Adjust, Lubricate, or Replace if necessary.

R: Replace, L: Lubricate

The following items require some mechanical knowledge. Certain items (particularly those marked \* and \*\*) may require more technical information and tools. Consult your authorized Honda dealer.

Item	Frequency	Whichever Comes First Note	Odometer Reading (Note 1)								Refer to page
			× 1000 mi	0.6	4	8	12	16	20	24	
			× 1000 km	1	6	12	18	24	30	36	
EMISSION RELATED ITEMS	* Fuel Line				I			I		I	Note 5
	* Throttle Operation				I			I		I	Note 5
	* Carburetor Choke				I			I		I	Note 5
	Air Cleaner	Note 2					R			R	3-6
	Spark Plug			I	R	I	R	I	R	3-7/Note 5	
	* Valve Clearance		I				I			3-7	
	Engine Oil		R		R		R		R	Note 5	
	Engine Oil Filter		R		R		R		R	Note 5	
	* Carburetor Synchronization		I		I		I		I	3-11/Note 5	
	* Carburetor Idle Speed		I	I	I	I	I	I	I	Note 5	
	Radiator Coolant	Note 3			I		I		R	Note 5	
	* Cooling System				I		I		I	Note 5	
	* Secondary Air Supply System				I		I		I	Note 5	
	* Evaporative Emission Control System	Note 4					I			I	Note 5
NON-EMISSION RELATED ITEMS	Drive Chain		I, L every 600 mi (1,000km)								3-12
	Brake Fluid	Note 3		I	I	R	I	I	R	Note 5	
	Brake Pad Wear			I	I	I	I	I	I	Note 5	
	Brake System		I		I		I		I	Note 5	
	* Brake Light Switch				I		I		I	Note 5	
	* Headlight Aim				I		I		I	3-15	
	Clutch System				I		I		I	Note 5	
	Clutch Fluid	Note 3		I	I	R	I	I	R	Note 5	
	Side Stand				I		I		I	3-15	
	* Suspension				I		I		I	Note 5	
	* Nuts, Bolts, Fasteners		I		I		I		I	Note 5	
	** Wheels/Tires				I		I		I	Note 5	
** Steering Head Bearings		I		I		I		I	Note 5		

- \* Should be serviced by an authorized Honda dealer, unless the owner has proper tools and service data and is mechanically qualified.
- \*\* In the interest of safety, we recommend these items be serviced only by an authorized Honda dealer.

- Notes:
1. At higher odometer readings, repeat at the frequency interval established here.
  2. Service more frequently when riding in unusually wet or dusty areas.
  3. Replace every 2 years, or at indicated odometer interval, whichever comes first.  
Replacement requires mechanical skill.
  4. California type only.
  5. Refer to the Common Service Manual.

After '93:

Per from the PRE-RIDE INSPECTION in the Owner's Manual at each scheduled maintenance period.

I: Inspect and Clean, Adjust, Lubricate, or Replace if necessary.

R: Replace, L: Lubricate

The following items require some mechanical knowledge. Certain items (particularly those marked \* and \*\*) may require more technical information and tools. Consult your authorized Honda dealer.

Item	Frequency	Whichever Comes First ↓ Note	Odometer Reading (Note 1)								Refer to page	
			→	× 1000 mi	0.6	4	8	12	16	20		24
			× 100 km									
EMISSION RELATED ITEMS	* Fuel Line				I			I			I	Note 5
	* Throttle Operation						I		I		I	Note 5
	* Carburetor Choke						I		I		I	Note 5
	* Air Cleaner		Note 2					R			R	3-6
	Spark Plug				I	R	I	R	I	R		3-7/Note 5
	* Valve Clearance								I			3-7
	Engine Oil			R		R		R		R		Note 5
	Engine Oil Filter			R		R		R		R		Note 5
	* Carburetor Synchronization					I		I		I		3-11/Note 5
	* Carburetor Idle Speed			I	I	I	I	I	I	I	I	Note 5
	Radiator Coolant		Note 3				I		I		R	Note 5
	* Cooling System					I		I		I		Note 5
	* Secondary Air Supply System					I		I		I		Note 5
	* Evaporative Emission Control System							I			I	Note 5
NON-EMISSION RELATED ITEMS	Drive Chain		I,L every 600 mi (1,000km)								3-12	
	Brake Fluid		Note 3		I	I	R	I	I	R		Note 5
	Brake Pad Wear				I	I	I	I	I	I		Note 5
	Brake System			I		I		I		I		Note 5
	* Brake Light Switch					I		I		I		Note 5
	* Headlight Aim					I		I		I		3-15
	Clutch System					I		I		I		Note 5
	Clutch Fluid		Note 3		I	I	R	I	I	R		Note 5
	Side Stand					I		I		I		3-15
	* Suspension					I		I		I		Note 5
	* Nuts, Bolts, Fasteners			I		I		I		I		Note 5
** Wheels/Tires					I		I		I		Note 5	
** Steering Head Bearings			I		I		I		I		Note 5	

\* Should be serviced by an authorized Honda dealer, unless the owner has proper tools and service data and is mechanically qualified.

\*\* In the interest of safety, we recommend these items be serviced only by an authorized Honda dealer.

Notes: 1. At higher odometer readings, repeat at the frequency interval established here.

2. Service more frequently when riding in unusually wet or dusty areas.

3. Replace every 2 years, or at indicated odometer interval, whichever comes first.

Replacement requires mechanical skill.

4. California type only.

5. Refer to the Common Service Manual.

## Air Cleaner

Remove the following:

- fuel tank (page 2-22).
- air cleaner housing cover

Replace the air cleaner in accordance with the maintenance schedule.

Also, replace the air cleaner when ever it becomes excessively dirty or damaged.

Install the cleaner with the "TOP" mark facing up.

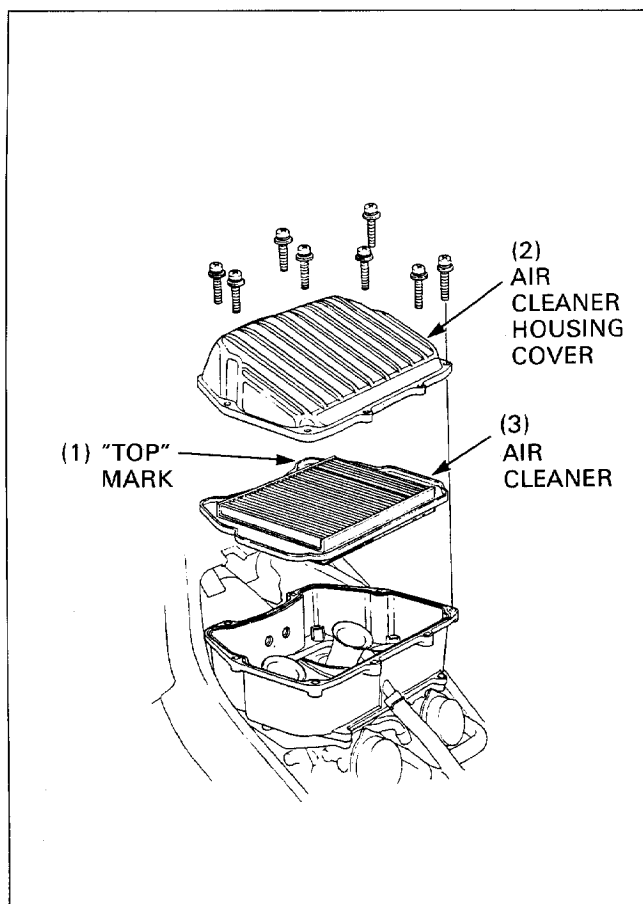

### Sub air cleaner:

Remove the sub air cleaner from the housing and wash away any accumulated dust or dirt, by gently squeezing it in non flammable or high flash point solvent.

#### ▲ WARNING

- Using gasoline or low flash point solvents for cleaning parts may result in a fire or explosion.

Spread Pro Honda Foam Filter Oil or equivalent on the sub air cleaner. Rub it in thoroughly over the surface with both hands, and then squeeze out any excess oil.

#### NOTE

- Be sure to allow the sub air cleaner to dry thoroughly before applying oil. Otherwise, the oil will be diluted by the solvent and the filtering ability of the filter will be much less effective.

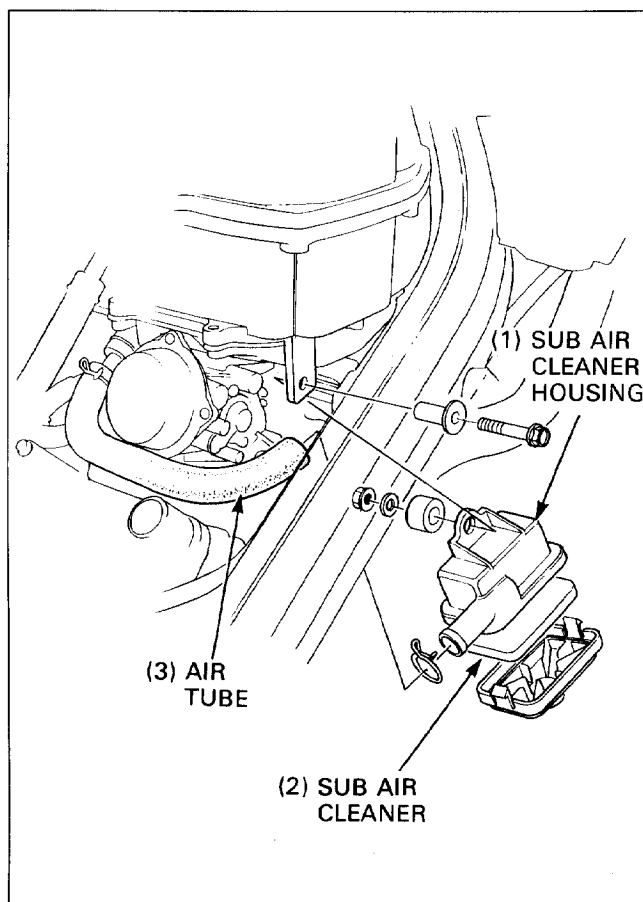

## Spark Plug

Refer to page 1-13 for the recommended plugs and plug gap specification.

Remove the lower center fairing (page 2-8).

Place the front wheel in the straight ahead position.

Remove the lower radiator mounting bolt, loosen the upper mounting bolt and swing the radiator forward, then secure it with a piece of wire.

### CAUTION

- Be careful not to damage the radiator fins.

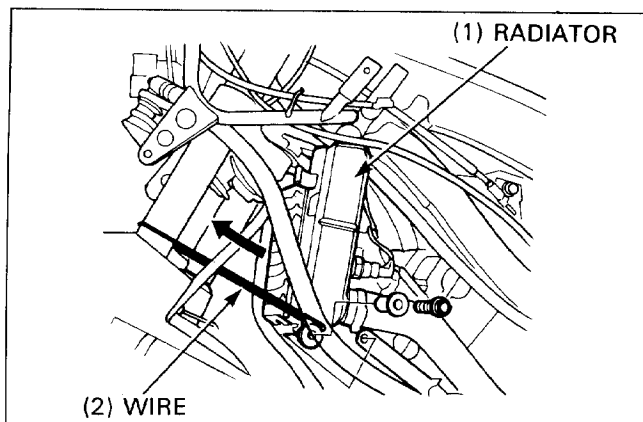

Disconnect the spark plug caps from the #2 and #4 cylinders.

Clean any dirt from around the spark plug bases.

Remove the #2 and #4 cylinder spark plugs.

### '90-'93:

Remove the seat (page 2-2).

Remove the fuel tank mounting bolt and nut.

Raise the fuel tank rear side and install the special tool (included in the tool kit) as shown.

### After '93:

Remove the rear fairing (page 2-3).

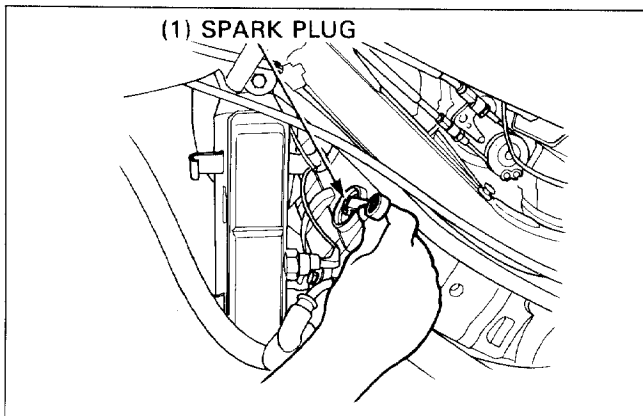

Disconnect the #1 and #3 cylinder spark plug caps from the spark plugs.

Clean any dirt from around the spark plug bases.

Remove the #1 and #3 cylinder spark plugs.

Adjust air gap if necessary. Install the spark plugs.

**Torque: 12 N·m (1.2 kg·m, 9 ft·lb)**

Install the removed parts in the reverse order of removal.

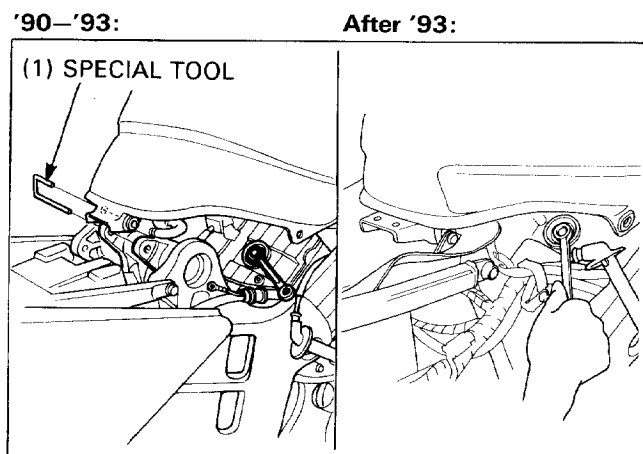

## Valve Clearance

### Inspection

### NOTE

- Inspect and adjust valve clearance while the engine is cold (Below 35°C/95°F).

Remove the following:

- timing hole cap
- seat (page 2-2)
- fuel tank (page 2-22)
- middle fairings (page 2-4)

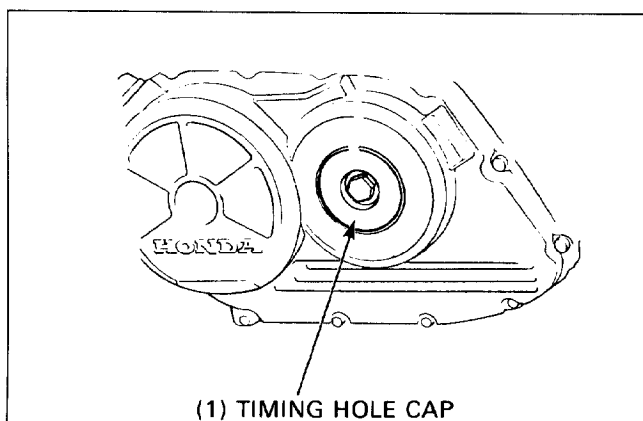

## Maintenance

Remove the lower radiator mounting bolt and loosen the upper bolt.  
Pull the oil cooler hoses out of the clips on both sides of the radiator.  
Remove the front of the right rubber air deflector from the hook under the right side of the radiator.  
Swing the radiator forward and secure it with a piece of wire.

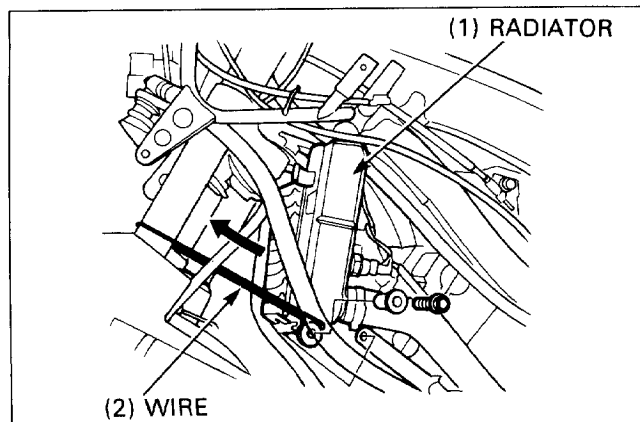

### CAUTION

- Be careful not to damage the radiator fins.

Remove the #2 and #4 cylinder head cover by removing the cover bolts and mounting rubbers.

Remove the crankcase breather tube from the #1 and #3 cylinder head cover.

Remove the spark plug caps from the spark plugs.

Remove the #1 and #3 cylinder head cover by removing the cover bolts and mounting rubbers.

Measure and adjust the intake and exhaust valve clearances as described below.

Rotate the crankshaft clockwise to align the T1 mark with the index mark on the right crankcase cover.

Make sure the #1 piston is at TDC (Top Dead Center) on the compression stroke.

Check the valve clearance by inserting a feeler gauge between the cam lobe and valve lifter.  
Measure the valve clearance for the #1 cylinder and record it.

### Valve clearance:

**Intake:  $0.16 \pm 0.03$  mm ( $0.006 \pm 0.001$  in)**

**Exhaust:  $0.25 \pm 0.03$  mm ( $0.010 \pm 0.001$  in)**

Rotate the crankshaft clockwise 1/2 turn (180 degrees) to align the T3 mark with the index mark on the right crankcase cover.  
Measure the valve clearance for the #3 cylinder and record it.

Rotate the crankshaft clockwise 3/4 turn (270 degrees) to align the T2 mark with the index mark on the right crankcase cover.  
Measure the valve clearance for the #2 cylinder and record it.

Rotate the crankshaft clockwise 1/2 turn (180 degrees) to align the T4 mark with the index mark on the right crankcase cover.  
Measure the valve clearance for the #4 cylinder and record it.

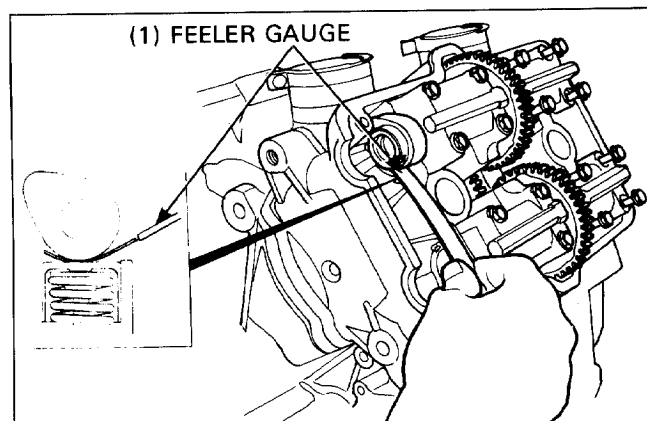
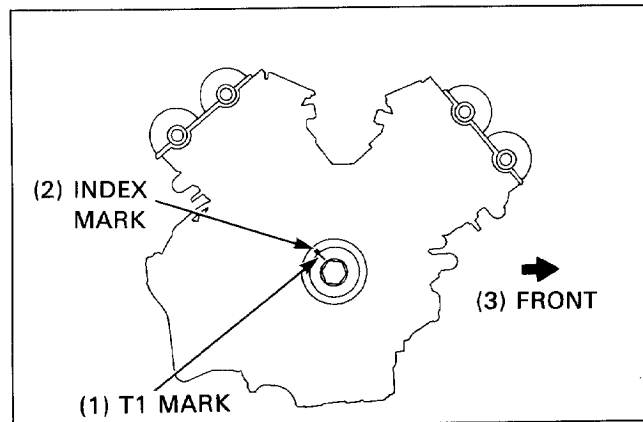
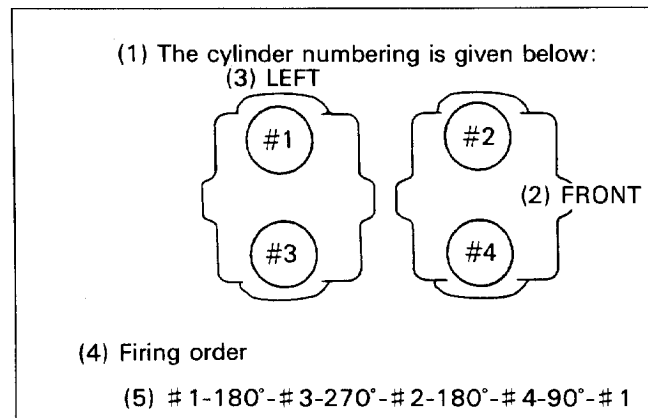

If the clearance is not correct:  
 Remove the camshafts (page 8-2).  
 Remove the valve lifters and shims.

**NOTE**

- Do not allow shims to fall into the crankcase. The shim(s) may occasionally stick to the lifter.
- Mark all lifters and shims to ensure correct reassembly.
- It is easy to remove the valve lifter with a valve lapping tool or magnet.
- Remove the shims with tweezers or a magnet.

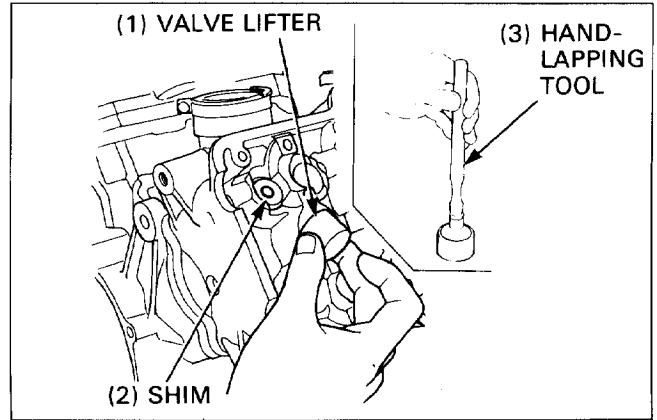

**Shim selection:**

Clean the valve retainers with compressed air.

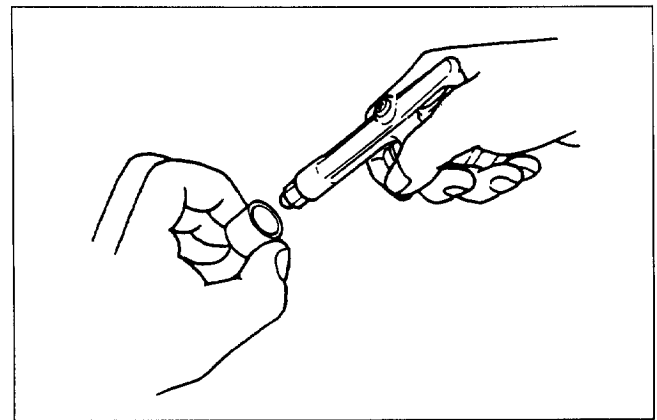

Measure the shim thickness with a micrometer and record it.

**NOTE:**

- Sixtyfive shims are available in thickness intervals of 0.025 mm. The thinnest is 1.200 mm, the thickest is 2.800mm.

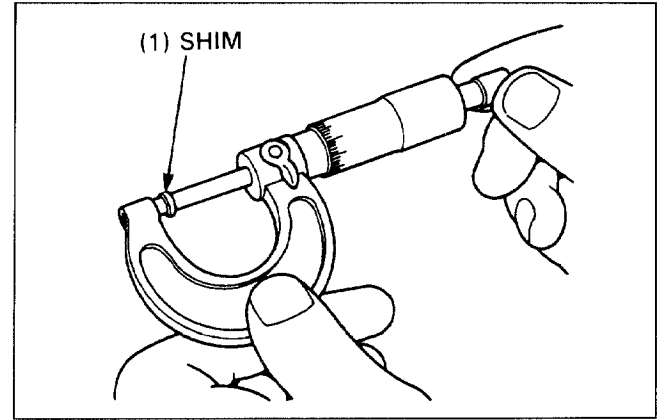

To confirm your shim choice, you may use the following formula:

- $a = (b - c) + d$
- a: New shim thickness
  - b: Recorded valve clearance
  - c: Specified valve clearance
  - d: Old shim thickness

**Example:**

**Recorded valve clearance: 0.06 mm**  
**Old shim thickness: 1.875 mm**  
**Specified valve clearance: 0.16 mm**

$a = (0.06 - 0.16) + 1.875 \text{ mm}$   
 $a = 1.775$

**NOTE**

- If the required thickness of the new shim is more than 2.800 mm, the valve seat is probably heavily carboned. Reface the seat, recheck valve clearance and reselect the shim.

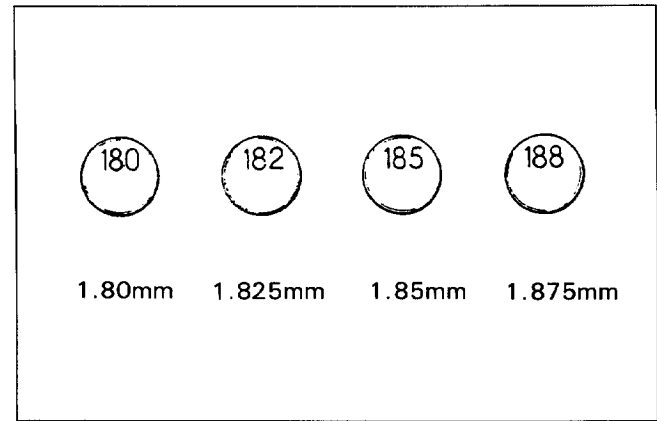

## Maintenance

Apply a Honda Bond A or equivalent to the cylinder head cover grooves as shown.

Install the cover gasket with the IN mark the cover gasket facing the intake side.

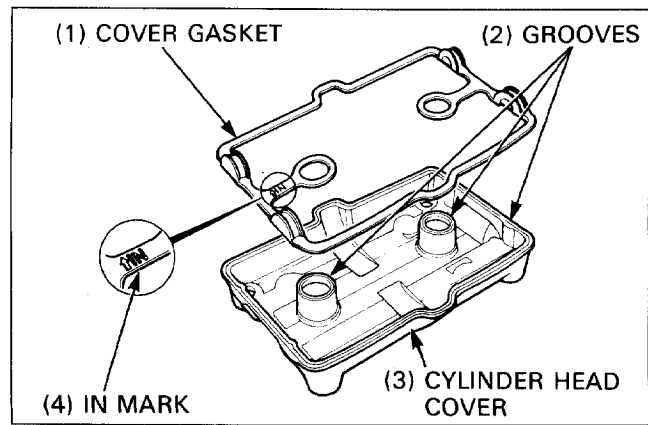

Install the cover bolt washer with the UP mark facing up.

Tighten the cover bolts.

**Torque: 10N · m (1.0kg-m, 7ft-lb)**

Install the removed parts in the reverse order of removal.

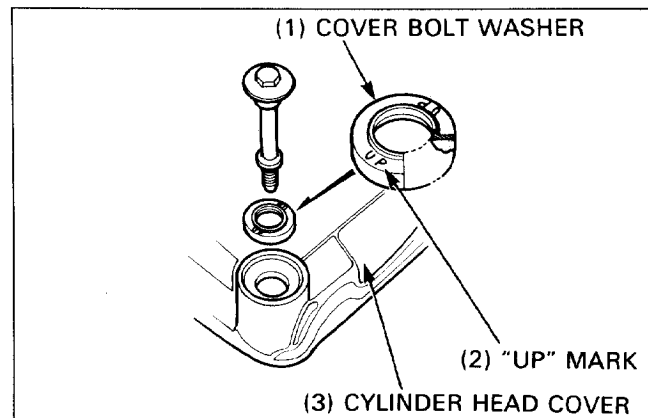

# Carburetor Synchronization

## NOTE

- For detailed instructions, refer to section 2 of the Common Service Manual. The information here only indicates locations of the plugs for the adapters and the synchronization adjusting screws.
- Synchronize the carburetors with the engine at normal operating temperature, the transmission in neutral and the motorcycle in an upright position.

Carburetor vacuum difference: Within 20 mmHg (0.8 inHg)

Base carburetor: '90-'93: No. 2 carburetor  
After '93: No. 1 carburetor

## Idle speed:

('90-'93)

49 state/Canada type:  $1,000 \pm 100$  rpm

California type:  $1,200 \pm 100$  rpm

(After '93)

49 state type:  $1,100 \pm 100$  rpm

California type:  $1,200 \pm 100$  rpm

Canada type:  $1,000 \pm 100$  rpm

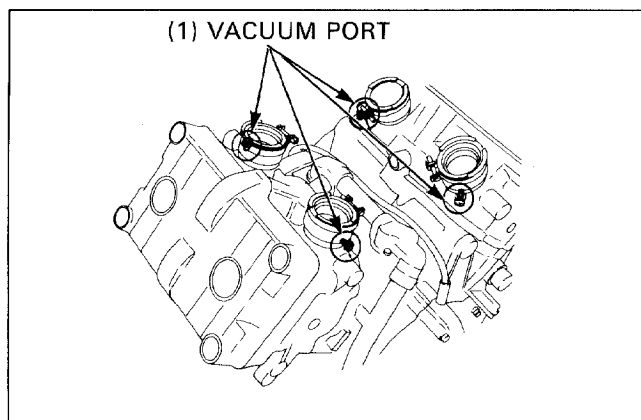

'90-'93:

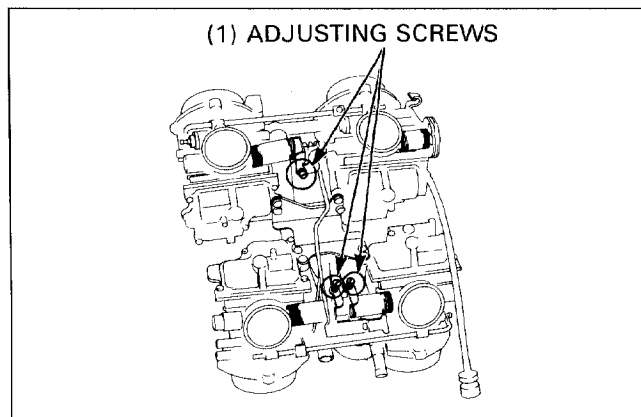

After '93:

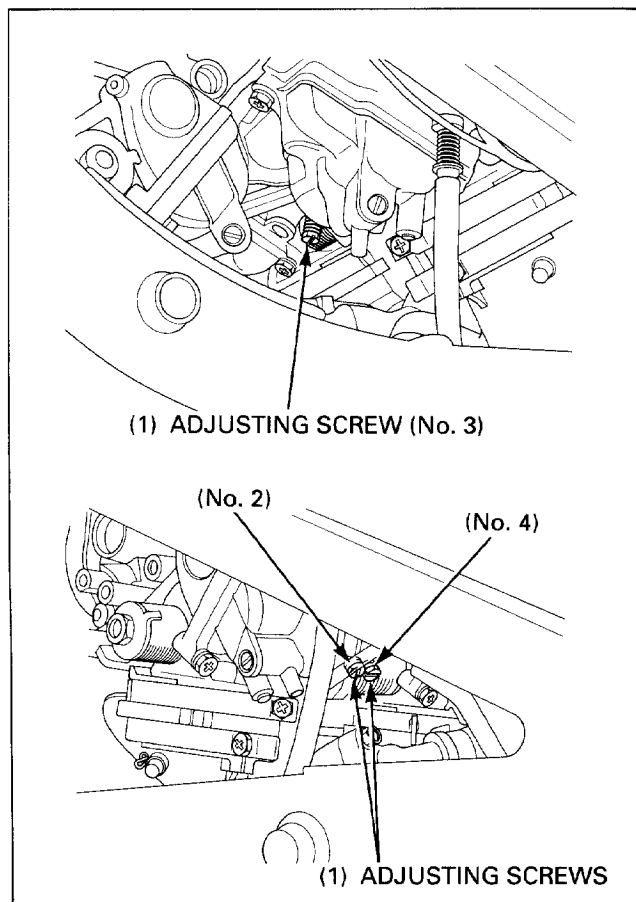

# Drive Chain

## Drive Chain Slack Inspection

**⚠ WARNING**

- Inspecting the drive chain while the engine is running can result in serious hand or finger injury.

Turn the engine off, place the motorcycle on the side stand and shift the transmission into neutral. Check slack in the drive chain lower run midway between the sprockets.

**Slack: 15–25 mm (0.6–1.0 in)**

**NOTE**

- Measure slack between upper and lower extremities of a link center as shown.

**CAUTION**

- Excessive chain slack, 40 mm (1.6 in) or more, may damage the frame.

### To Adjust

Loosen the bearing holder pinch bolt.

Adjust the drive chain slack by turning the bearing holder using the pin spanner and handle (Included in tool kit).

Tighten the bearing holder pinch bolt.

**Torque: 55 N·m (5.5 kg-m, 40 ft-lb)**

Recheck chain slack and free wheel rotation. Check the chain wear label. If the red zone on the label aligns with the teeth end of the driven sprocket after the chain has been adjusted, the chain must be replaced.

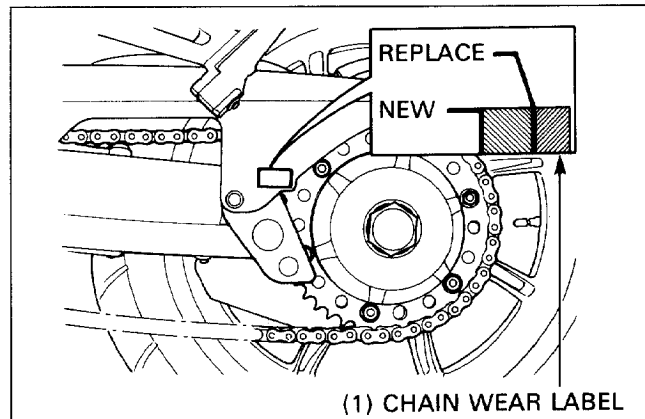
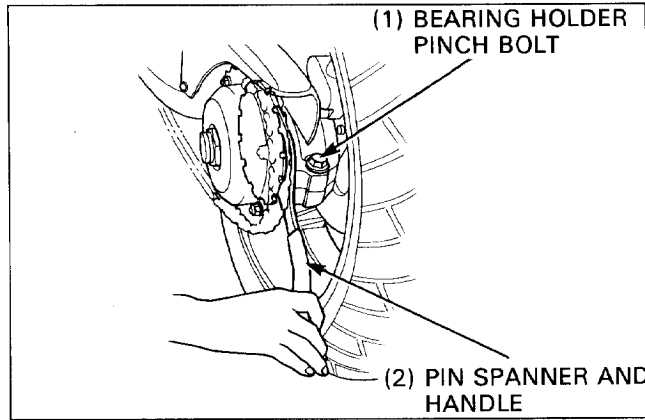
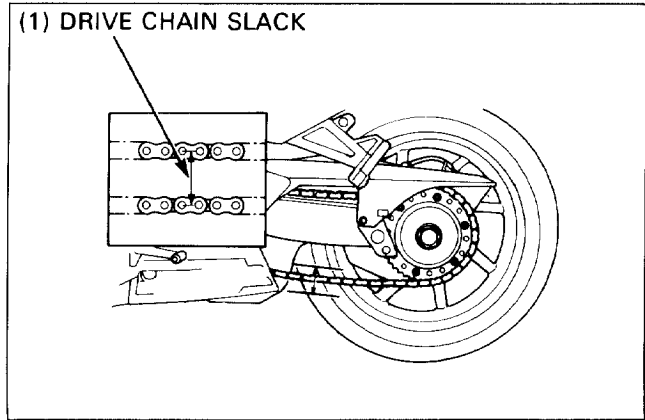

**Replacement**

**CAUTION**

• The VFR750F uses a drive chain with a staked master link. Use only the replacements specified. Never attempt to use a chain with a clip-type master link.

Loosen the drive chain.  
Assemble the special tool.

**S. TOOL**  
**Drive chain cutter** 07HMH-MR10102  
**- Link plate holder** 07NMH-MW00110

**NOTE**

• When using the special tool, follow the manufacturer's operating instructions.

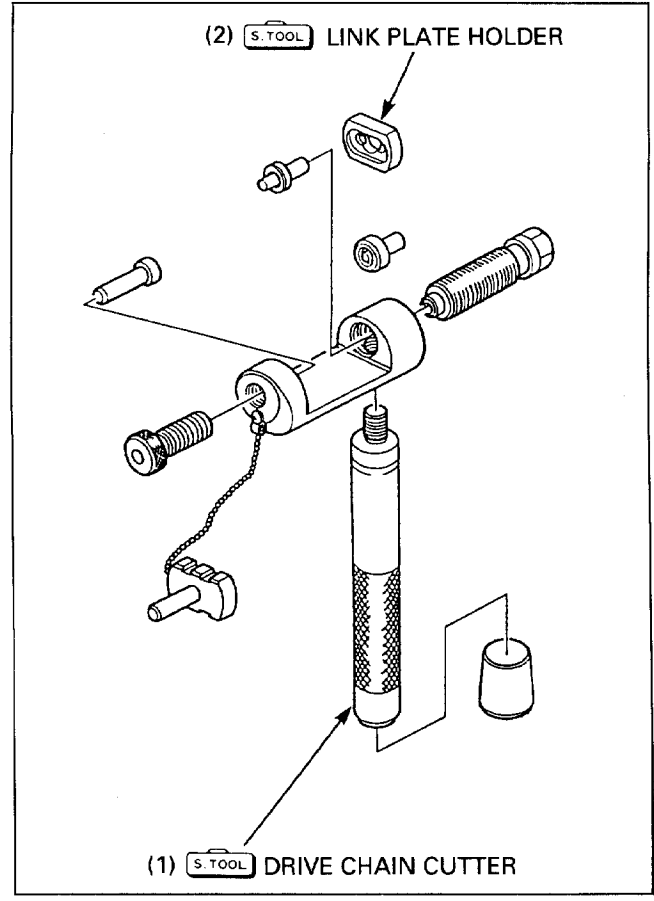

Locate the crimped pin ends of the master link from the outside of the chain and remove the link with the chain cutter.

Remove the drive chain.

Remove extra drive chain link(s) from the new drive chain using the drive chain cutter.

**NOTE**

• Include the master link when you count the drive chain links.

**Replacement chain:** DID.: DID50V4  
 RK: RK50MF0Z1

**Specified links:** 112 links

**CAUTION**

• Never reuse the old drive chain, master link, master link plate and O-rings.

Install the new drive chain.

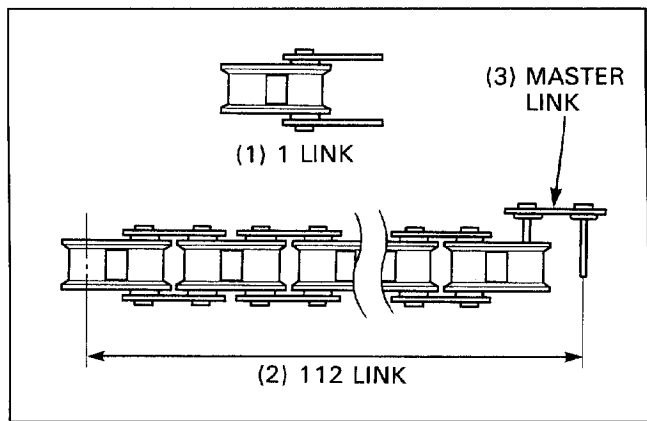
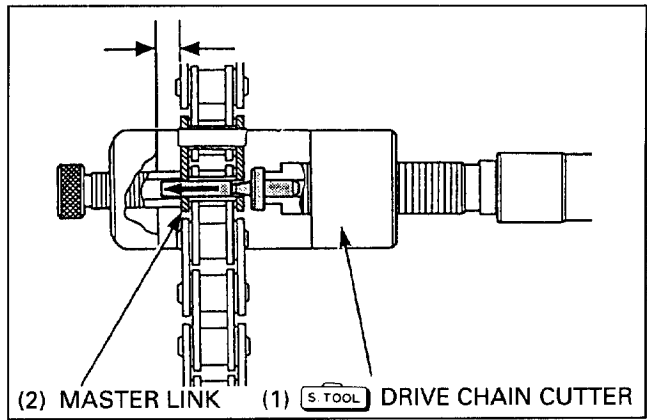

## Maintenance

Assemble the new master link, O-rings and plate.  
Insert the master link from the inside of the drive chain and install the plate with the identification mark facing the outside.

### CAUTION

- Improper positioning of the master link may cause the drive chain to come apart and possibly damage the crankcase, rear wheel or exhaust.

Assemble and set the drive chain cutter.  
Check that the master link pins are installed properly by measuring the master link pin length projected from the plate.

**Projection: DID: 1.15–1.55 mm (0.045–0.061 in)**

**RK: 1.2–1.4 mm (0.05–0.06 in)**

Stake the master link pins.

Make sure that the pins are staked properly by measuring the diameter of the staked area using a slide calipers.

**Diameter of the staked area:**

**DID: 5.5–5.8 mm (0.22–0.23 in)**

**RK: 5.55–5.85 mm (0.219–0.230 in)**

After staking, check the staked area for cracks.  
If there is any cracking, replace the master link, O-rings and plate.

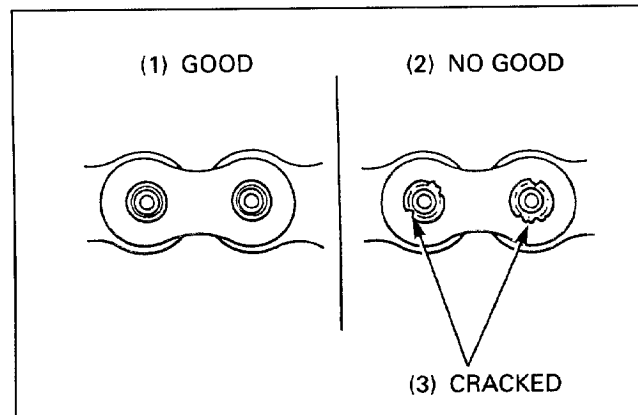
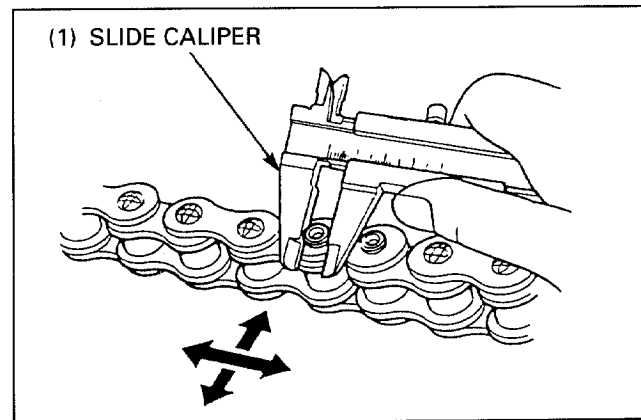
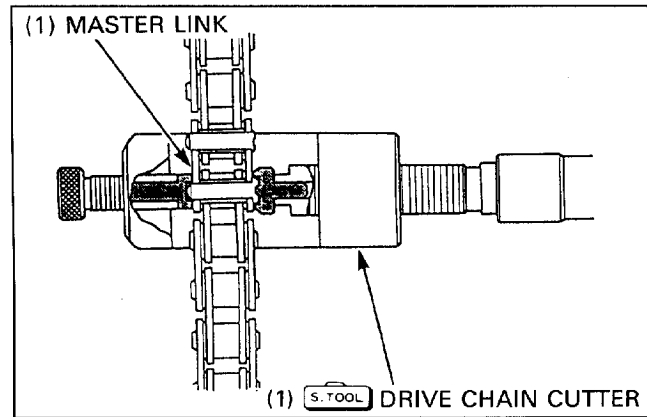
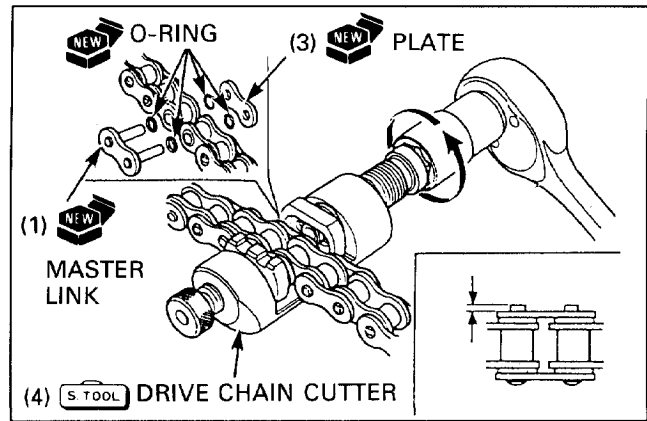

## Headlight Aim

### ⚠ WARNING

- An improperly adjusted headlight may blind oncoming drivers, or it may fail to light the road for a safe distance.

Adjust the headlight aim horizontally by turning the horizontal adjusting knobs.

Adjust the headlight aim vertically by turning the vertical adjusting knob.

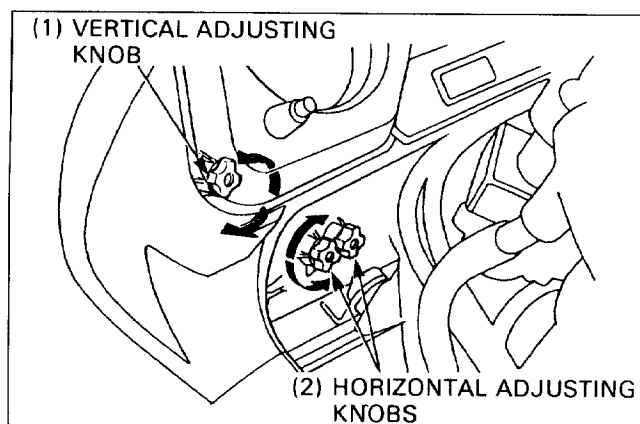

## Side Stand

Check the side stand ignition cut-off system:

- Support the motorcycle upright and raise the side stand.
- Start the engine with the transmission in neutral, then shift the transmission into gear with the clutch lever pull in.
- Lower the side stand fully.
- The engine should stop as the side stand is lowered.

If there is a problem with the system, check the side stand switch (Section 18).

Check the side stand switch mounting bolts for looseness.

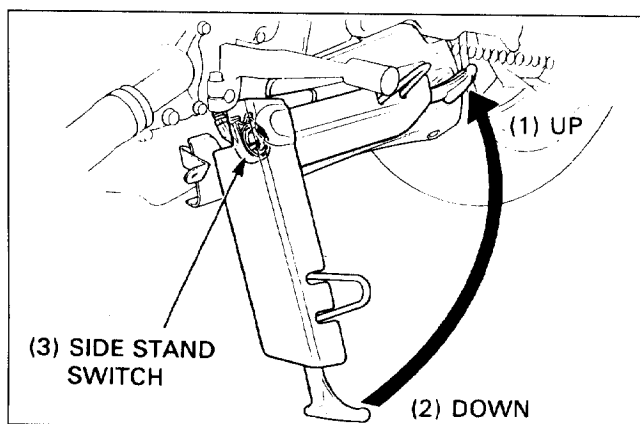



# 4. Lubrication System

Service Information	4-1	Oil Pump Removal/Installation	4-3
Troubleshooting	4-1	Oil Pump Disassembly/Assembly	4-4
Lubrication System Diagram	4-2	Oil Cooler Removal/Installation	4-5

## Service Information

### ⚠ WARNING

- **Used engine oil may cause skin cancer if repeatedly left in contact with the skin for prolonged periods. Although this is unlikely unless you handle used oil on a daily basis, it is still advisable to thoroughly wash your hands with soap and water as soon as possible after handling used oil. KEEP OUT OF REACH OF CHILDREN.**

- The oil pump can be serviced with the engine installed in the frame.
- Replace the oil pump as an assembly.
- For oil pressure check, refer to section 4 of the Common Service Manual; for the switch location, see page 18-2 of this manual.
- For oil pressure warning light inspection, refer to section 25 of the Common Service Manual.
- When removing and installing the oil pump use care not to allow dust or dirt to enter the engine.
- After the oil pump has been installed, check that there are no oil leaks and that oil pressure is correct.

## Troubleshooting

### Oil level low

- Oil consumption
- External oil leaks
- Worn piston ring or incorrect piston ring installation
- Worn valve guide or seal

### Oil contamination (White appearance)

- From coolant mixing with oil
  - faulty water pump mechanical seal
  - faulty cylinder guide or seal

### High oil pressure

- Pressure relief valve stuck closed
- Plugged oil filter, gallery or metering orifice
- Incorrect oil being used

### Low oil pressure

- Pressure relief valve stuck open
- Oil pump worn or damaged
- Internal oil leaks
- Incorrect oil being used
- Low oil level

### No oil pressure

- Low oil level
- Oil pump drive chain or oil pump drive/driven sprocket broken
- Oil pump damage (pump shaft)
- Internal oil leaks

### Oil pressure warning light does not work well

- Refer to section 25 of the Common Service Manual

# Lubrication System Diagram

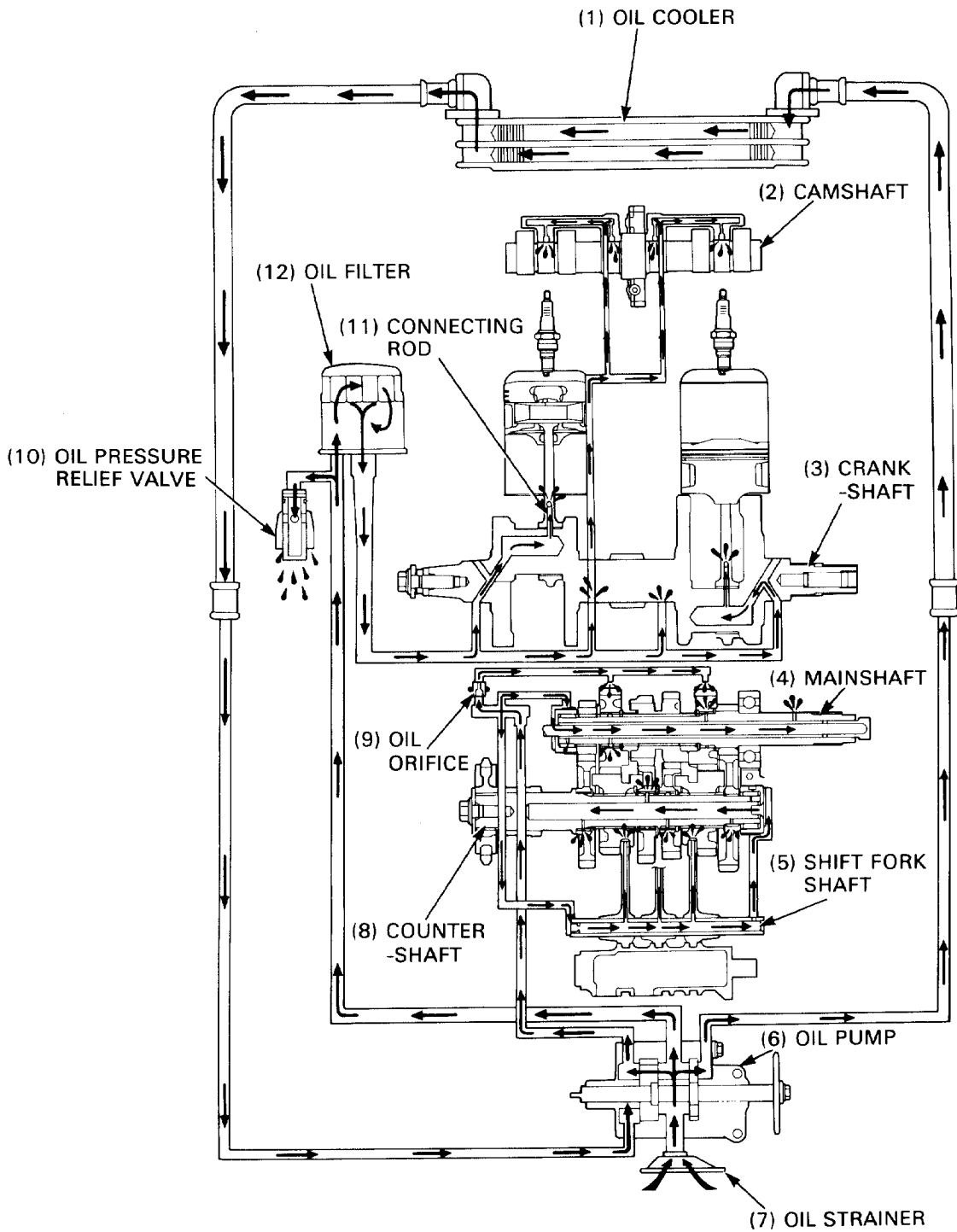

# Oil Pump Removal/Installation

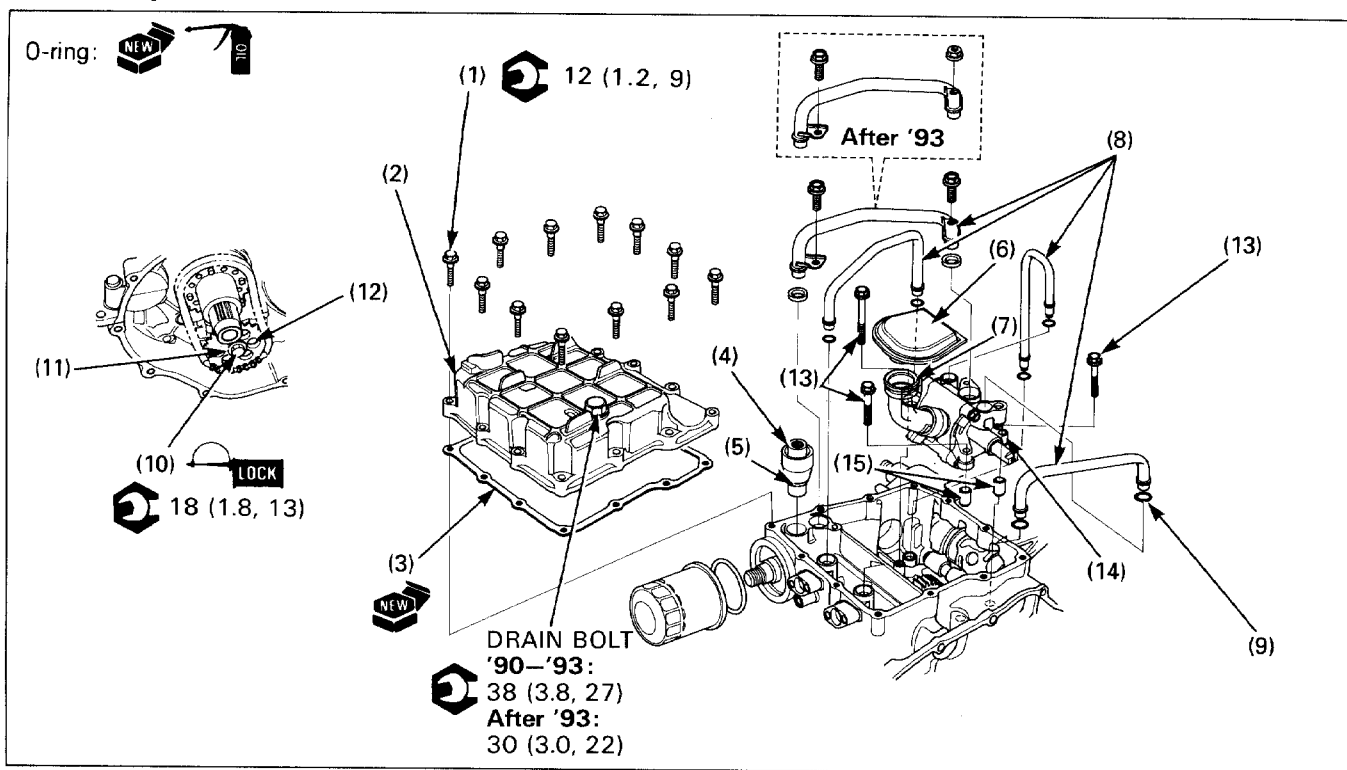

## Requisite Service

- Engine oil draining (location: page 3-2, see: section 2 of the Common Service Manual)
- Exhaust system removal/installation (page 2-14)
- Right crankcase cover removal/installation (page 9-2)
- Lower fairing removal/installation (page 2-7)

Procedure		Q'ty	Remarks
<b>Removal Order</b>			• Installation is in the reverse order of removal.
(1)	Oil pan bolt	12	
(2)	Oil pan	1	
(3)	Gasket	1	
(4)	Pressure relief valve	1	
(5)	O-ring	1	
(6)	Oil strainer	1	Clean with the non-flammable or high flash point solvent.
(7)	O-ring	1	
(8)	Oil pipe	4	
(9)	O-ring	8	
(10)	Oil pump driven sprocket bolt	1	Apply a locking agent to the tip of the threads (approx. 6 mm/0.2 in)
(11)	Washer	1	
(12)	Oil pump driven sprocket	1	Install with the "IN" mark facing in.
(13)	Oil pump mounting bolt	3	
(14)	Oil pump assembly	1	
(15)	Dowel pin	2	

# Oil Pump Disassembly/Assembly

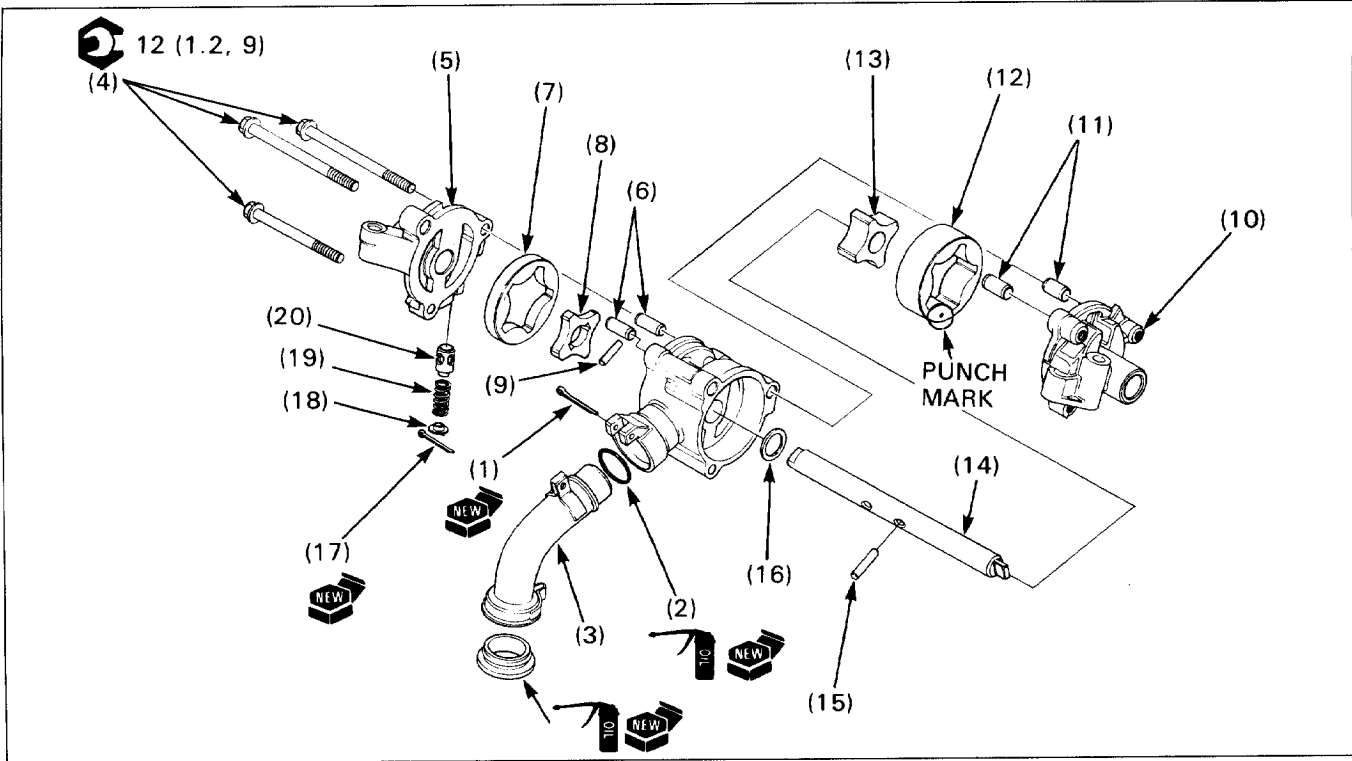

**NOTE**

- Before installing them, clean all removed parts thoroughly with clean engine oil.
- Refer to section 4 of the Common Service Manual for inspection information.
- Refer to page 1-6 for specification.

**Requisite Service**

- Oil pump removal/installation (page 4-3)

Procedure	Q'ty	Remarks
<b>Disassembly Order</b>		• Assembly is in the reverse order of disassembly.
(1) Cotter pin	1	
(2) O-ring	1	
(3) Oil strainer pipe	1	
(4) Oil pump cover attaching bolt	3	
(5) Pump cover	1	
(6) Dowel pin	2	
(7) Pump outer rotor	1	
(8) Pump inner rotor	1	Install aligning the cut out with the drive pin.
(9) Drive pin	1	
(10) Feed pump cover	1	
(11) Dowel pin	1	
(12) Feed pump outer rotor	1	Install with the punch mark facing the feed pump cover.
(13) Feed pump inner rotor	1	Install aligning the cut out with the drive pin.
(14) Pump shaft	1	
(15) Drive pin	1	
(16) Washer	1	
(17) Cotter pin	1	
(18) Spring seat	1	
(19) Spring	1	
(20) Relief valve	1	

# Oil Cooler Removal/Installation

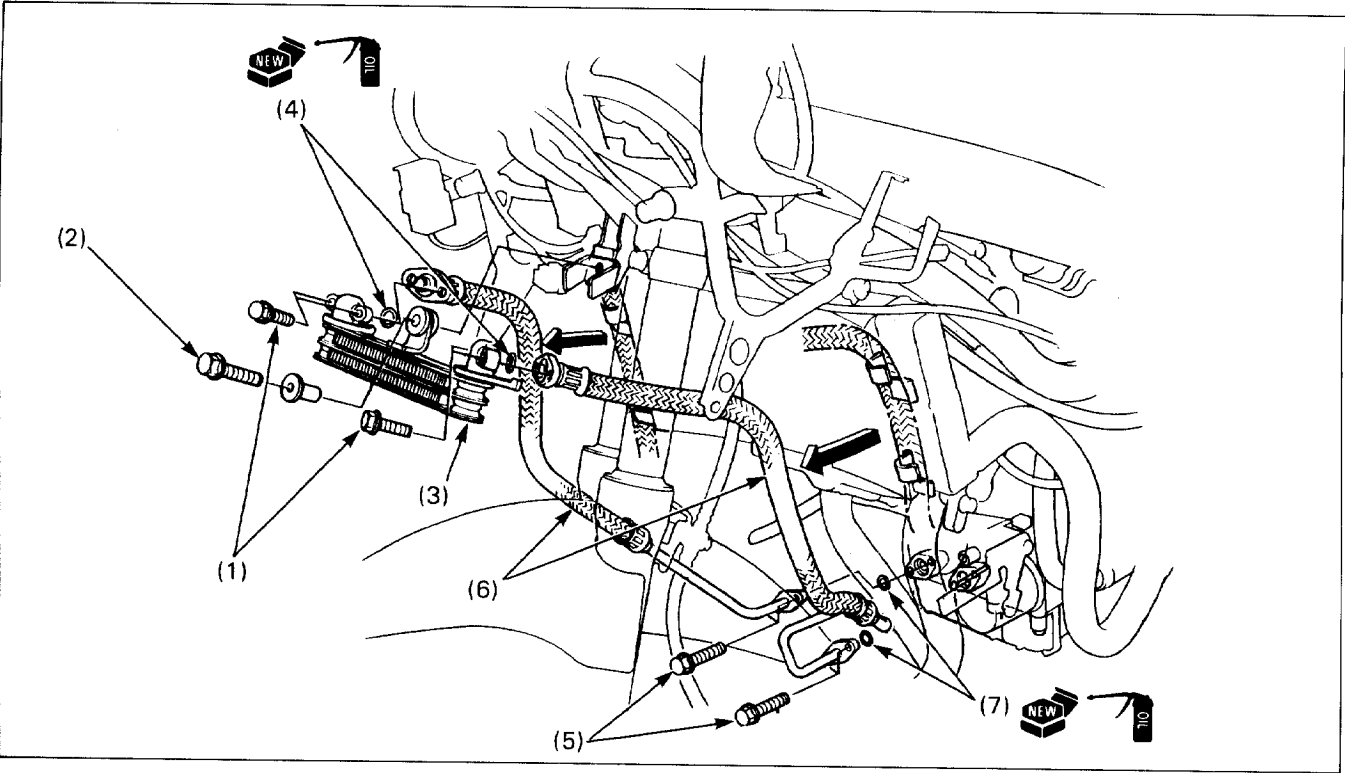

## Requisite Service

- Engine oil draining/refilling
- Middle fairing removal/installation (page 2-4)
- Lower fairing removal/installation (page 2-7)

Procedure	Q'ty	Remarks
<b>Removal Order</b>		• Installation is in the reverse order of removal.
(1) Oil hose joint bolt	4	
(2) Oil cooler mounting bolt	1	
(3) Oil cooler	1	
(4) O-ring	2	
(5) Oil pipe joint bolt	4	
(6) Oil hose	2	<b>NOTE:</b> • Be careful not to bend the oil pipe. • When installing, clamp the oil hose on the radiator and route correctly referring to page 1-29.
(7) O-ring	2	



# 5. Cooling System

Service Information	5-1	Thermostat Removal/Installation	5-4
Troubleshooting	5-1	Radiator Removal/Installation	5-5
System Flow Pattern	5-2	Radiator Disassembly/Assembly	5-6
Coolant Draining	5-3	Water Pump/Water pipe Disassembly/Assembly	5-7

## Service Information

### ⚠ WARNING

- Wait until the engine is cool before slowly removing the radiator cap. Removing the cap while the engine is hot and the coolant is under pressure may cause serious scalding.
- Radiator coolant is toxic. Keep it away from eyes, mouth, skin and clothes.
  - If any coolant gets in your eyes, rinse them with water and consult a doctor immediately.
  - If any coolant is swallowed, induce vomiting, gargle and consult a physician immediately.
  - If any coolant gets on your skin or clothes, rinse thoroughly with plenty of water.
- KEEP OUT OF REACH OF CHILDREN

- Add coolant at the reserve tank. Do not remove the radiator cap except to refill or drain the system.
- All cooling system service can be done with the engine in the frame.
- Avoid spilling coolant on painted surfaces.
- For coolant replacement, refer to section 5 of the Common Service Manual; in this manual, only the coolant draining procedure is described.
- After servicing the system, check for leaks with a cooling system tester.
- For fan motor switch and thermosensor locations and inspections, refer to section 18.

## Troubleshooting

### Engine temperature too high

- Faulty temperature gauge or thermosensor
- Thermostat stuck closed
- Faulty radiator cap
- Insufficient coolant
- Passages blocked in radiator, hoses or water jacket
- Air in system
- Faulty cooling fan motor
- Faulty fan motor switch
- Faulty water pump

### Coolant leaks

- Faulty oil pump mechanical seal
- Deteriorated O-ring
- Faulty radiator cap
- Damaged cylinder gasket
- Loose hose connection or clamp
- Damaged or deteriorated hoses

### Engine temperature too low

- Faulty temperature gauge or thermosensor
- Thermostat stuck open
- Faulty fan motor switch

# System Flow Pattern

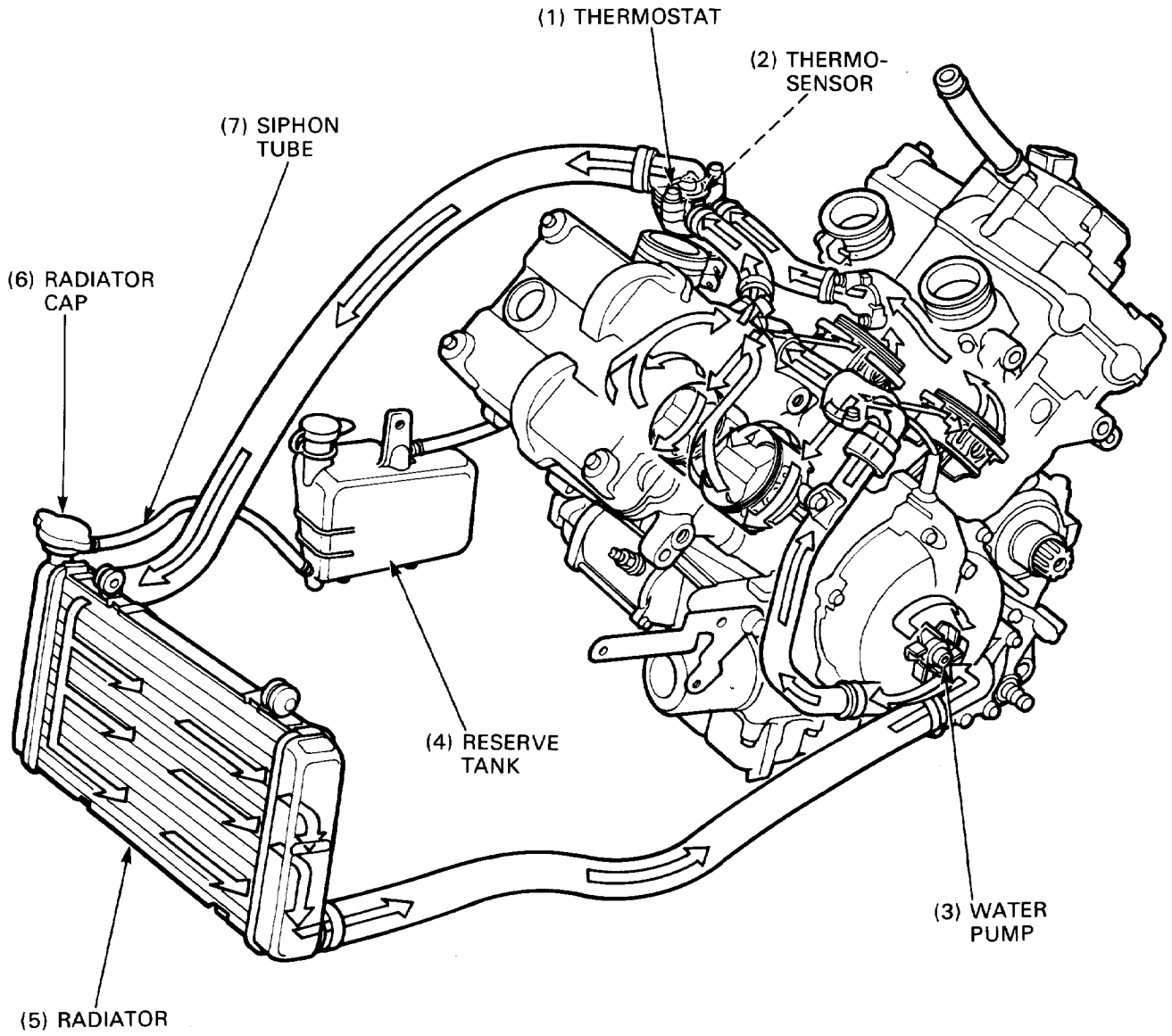

# Coolant Draining

## NOTE

- For coolant replacement, refer to section 5 of the Common Service Manual.

## CAUTION

- **Wait until the engine is cool before servicing the cooling system. Removing the radiator cap while the engine is hot and the coolant is under pressure may cause serious scalding.**

**To drain the coolant, remove the following.**

- fuse box
- radiator cap
- water pump drain bolt and sealing washer

Remove the cylinder drain bolts and sealing washers and drain the coolant completely from the system.

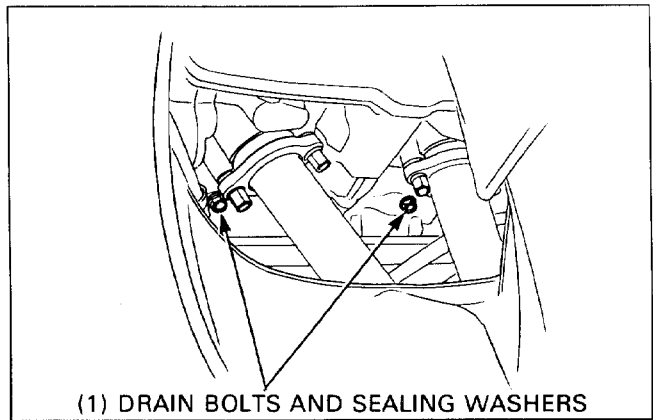
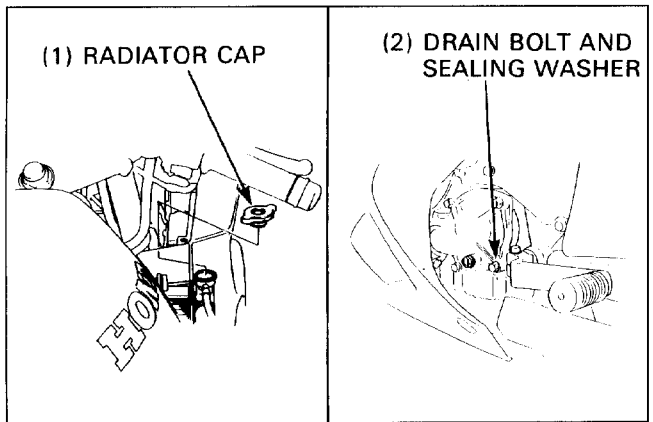

## Thermostat Removal/Installation

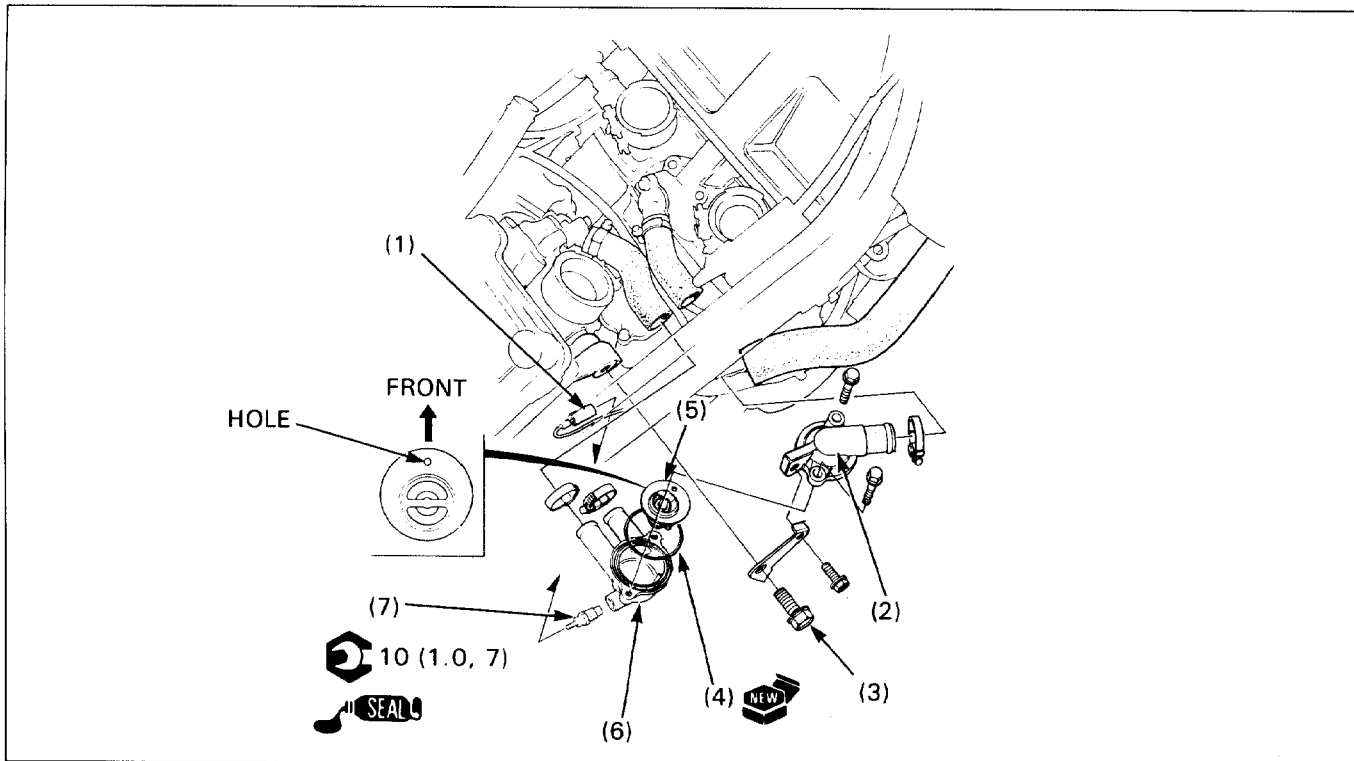

### Requisite Service

- Fuel tank removal/installation (page 2-22)
- Coolant refill (section 5 of the Common Service Manual)
- Coolant draining (page 5-3)
- Carburetor removal/installation (page 6-4)

Procedure	Q'ty	Remarks
<b>Removal Order</b>		• Installation is in the reverse order of removal.
(1) Thermosensor connector	1	
(2) Thermostat cover	1	After inserting into the radiator hose, secure it by tightening the hose band screw.
(3) Thermostat cover mounting bolt	1	
(4) O-ring	1	
(5) Thermostat	1	Install the thermostat with its hole forwards.
(6) Thermostat housing	1	After inserting into the water hoses, secure by tightening the hose band screw.
(7) Thermosensor	1	At installation, apply sealant to the threads.

# Radiator Removal/Installation

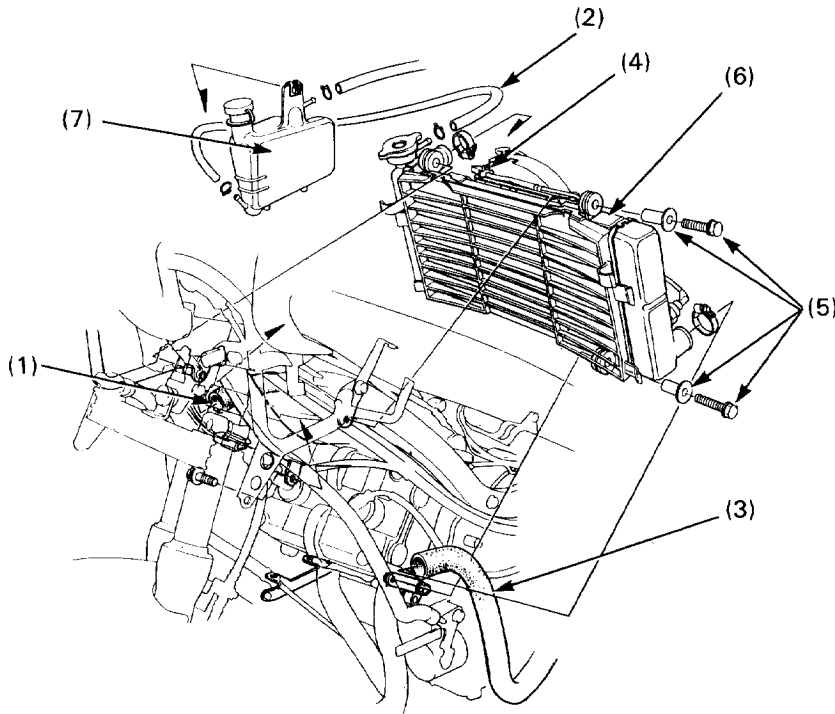

## Requisite Service

- Lower fairing removal/installation (page 2-7)
- Coolant draining (page 5-3)
- Coolant refill (section 5 of the Common Service Manual)

Procedure	Q'ty	Remarks
<b>Removal Order</b>		• Installation is in the reverse order of removal.
(1) Upper radiator hose	1	After connecting with the radiator, secure it with hose band or hose clip.
(2) Siphon tube	1	
(3) Lower radiator hose	1	
(4) Fan motor switch connector	1	
(5) Radiator mounting bolt/collar	2/2	
(6) Radiator assembly	1	Remove it after releasing the projection on the right-radiator stay.
(7) Reserve tank	1	When installing, insert the projections on the bottom of the tank into holes in stay.

# Radiator Disassembly/Assembly

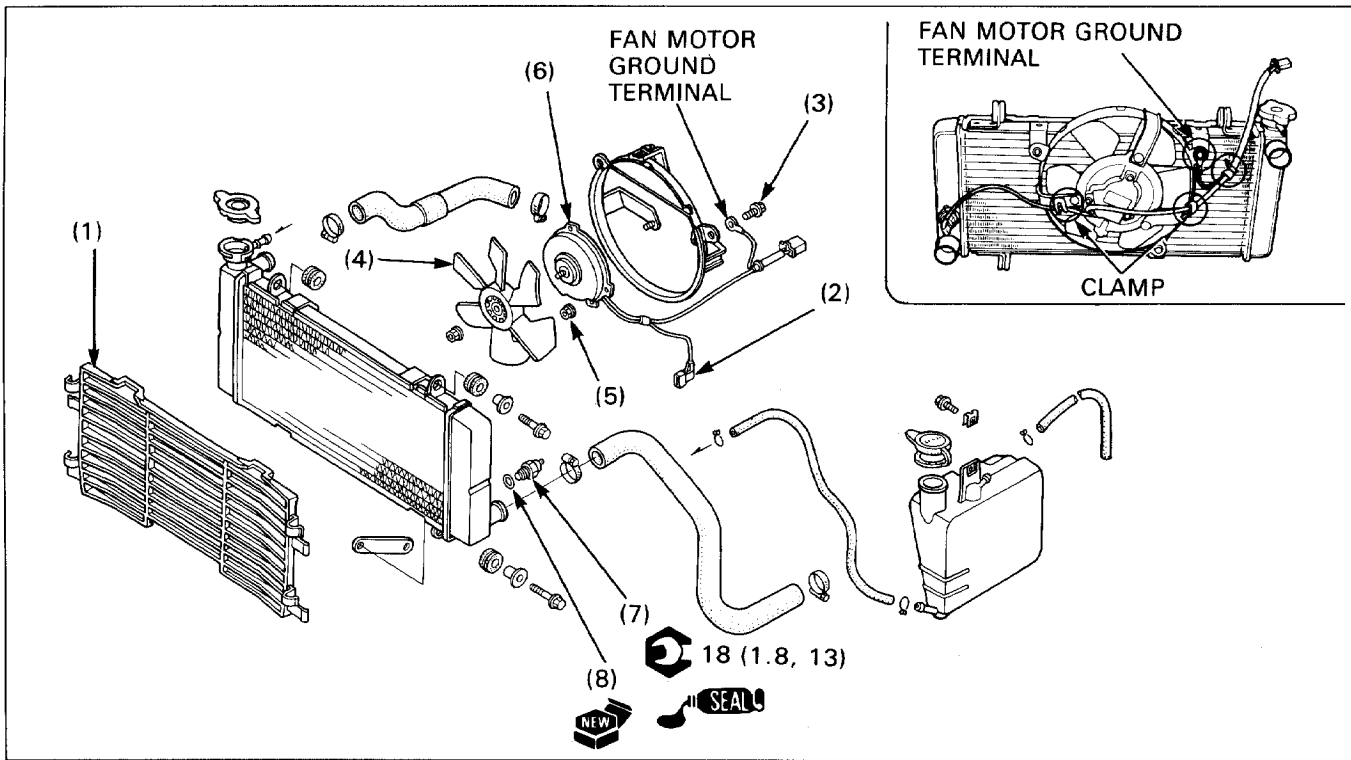

## Requisite Service

- Radiator removal/installation (page 5-5)

Procedure	Q'ty	Remarks
<b>Disassembly Order</b>		
(1) Radiator grille	1	• Assembly is in the reverse order of disassembly. At installation, align four grille grooves with the radiator lugs.
(2) Fan motor switch connector	1	
(3) Fan motor shroud mounting bolt	3	At installation, install the fan motor ground wire terminal properly as shown.
(4) Cooling fan	1	At installation, align the fan groove with the motor shaft.
(5) Fan motor mounting nut	3	
(6) Fan motor	1	
(7) Fan motor switch	1	At installation, apply sealant to the threads. <b>CAUTION</b> • Do not over-tighten the fan motor switch, or the radiator may be damaged.
(8) O-ring	1	

# Water Pump/Water Pipe Disassembly/Assembly

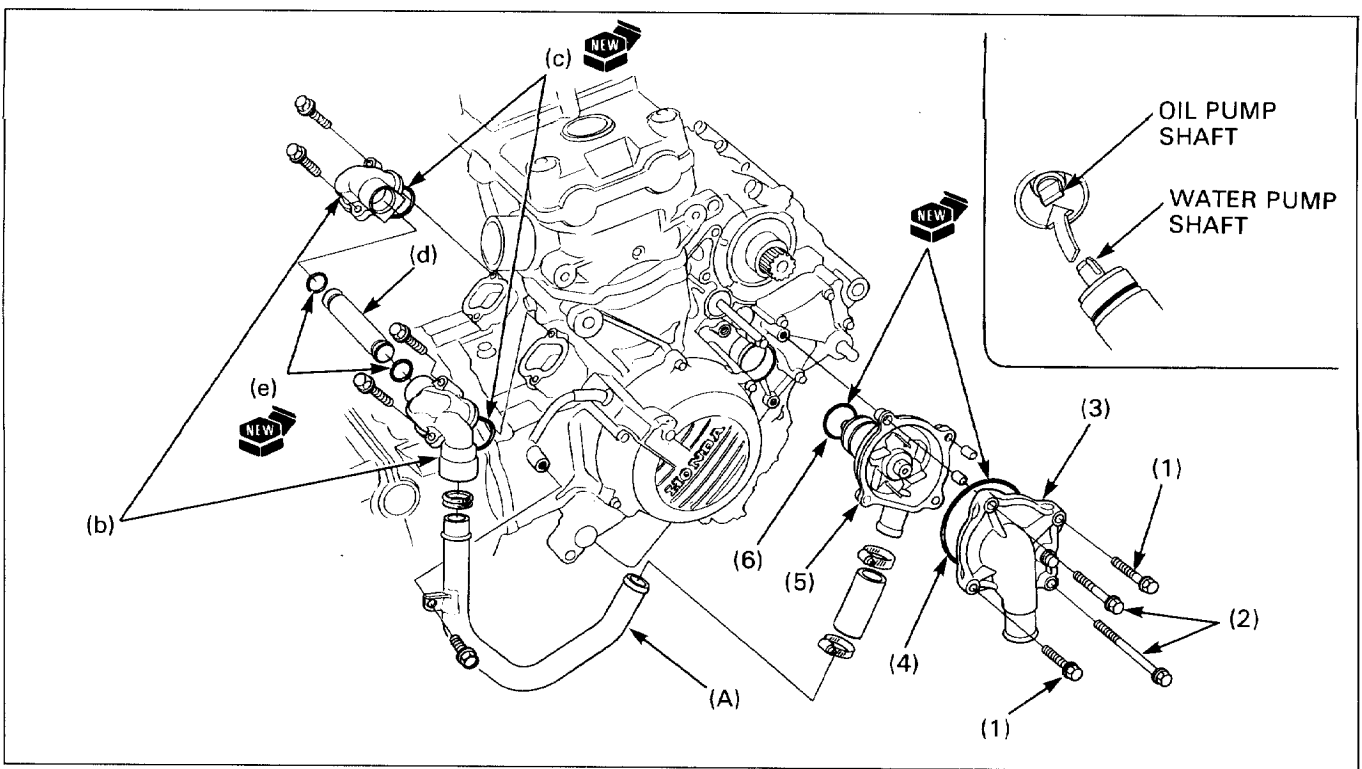

**NOTE**

- If the mechanical seal is damaged, the water pump must be replaced as an assembly.

**Requisite Service**

- Coolant draining (page 5-3)
- Coolant refill (section 5 of the Common Service Manual)
- Lower fairing removal/installation (page 2-7)

Procedure	Q'ty	Remarks
<b>Disassembly Order</b>		
<b>Water pump disassembly</b>		
(1) Water pump cover bolt	2	<ul style="list-style-type: none"> <li>• Assembly is in the reverse order of disassembly.</li> <li>At installation, align the pump shaft slot with the oil pump shaft end.</li> </ul>
(2) Water pump mounting bolt	2	
(3) Water pump cover	1	
(4) O-ring	1	
(5) Water pump body	1	
(6) O-ring	1	
<b>Water pipe disassembly</b>		
(a) Water pipe	1	Refer to page 6-4 for carburetor removal/installation.
(b) Water pipe joint	2	
(c) O-ring	2	
(d) Joint pipe	1	
(e) O-ring	2	



# 6. Fuel System

Service Information	6-1	Carburetor Separation (After '93)	6-10
Troubleshooting	6-2	Carburetor Combination (After '93)	6-12
Air Cleaner Housing Removal/Installation	6-3	Carburetor Disassembly/Assembly	6-16
Carburetor Removal/Installation	6-4	Pilot Screw Adjustment	6-22
Fuel Tank Disassembly/Assembly	6-6	High Altitude Adjustment(U.S.A. Only)	6-24
Carburetor Separation/Combination ('90-'93)	6-8	Secondary Air Supply System (U.S.A. Only)	6-25

## Service Information

### ▲ WARNING

- Gasoline is extremely flammable and is explosive under certain conditions. Work in a well ventilated area. Smoking or allowing flames or sparks in the work area or where gasoline is stored can cause fire or explosion.
- Bending or twisting the control cables will impair smooth operation and could cause the cables to stick or bind, resulting in loss of vehicle control.

### CAUTION

- To prevent damage, be sure to remove the diaphragms before cleaning air and fuel passages with compressed air. The diaphragms might be damaged.

### NOTE

- If the vehicle is to be stored for more than one month, drain the float chambers into an approved gasoline container. Fuel left in the float chambers may cause clogged jets resulting in hard starting or poor driveability.

- For fuel tank and fuel pump removal/installation, see section 2.
- When disassembling fuel system parts, note the locations of the O-rings. Replace them with new ones on reassembly.
- Before removing the carburetors, place an approved gasoline container under the carburetor drain tube, loosen the drain bolts and drain the carburetors.
- After removing the carburetors, cover the intake port of the engine with a shop towel or cover it with pieces of tape to prevent any foreign material from dropping into the engine.
- The vacuum chamber and float chamber can be serviced with the carburetors assembled.
- California Type Only:  
All hoses used in the evaporative emission control system are numbered for identification. When connecting one of these hoses, compare the hose number with the Vacuum Hose Routing Diagram Label, page 1-44.

## Troubleshooting

### Engine won't start

- No fuel to carburetors
  - fuel strainer clogged
  - fuel tube clogged
  - float valve stuck
  - float level misadjusted
  - fuel tank breather tube clogged
  - fuel pump malfunction
- Too much fuel getting to the engine
  - air cleaner clogged
  - flooded carburetors
- Intake air leak
- Fuel contaminated/deteriorated
- Slow circuit or starting enrichment circuit clogged
- Ignition malfunction

### Engine stalls, hard to start, rough idling

- Fuel line restricted
- Ignition malfunction
- Fuel mixture too lean/rich
- Fuel contaminated/deteriorated
- Intake air leak
- Idle speed misadjusted
- Fuel pump malfunction
- Pilot screw misadjusted
- Slow circuit or starting enrichment circuit clogged
- Float level misadjusted
- Fuel tank breather tube clogged
- Evaporative emission control system malfunction (U.S.A. Only)
  - PAIR control valve faulty
  - loose, disconnected or deteriorated hoses of the evaporative emission control system

### Afterburn on deceleration

- Lean mixture in slow circuit
- Evaporative emission control system malfunction (U.S.A. Only)
  - secondary air supply system faulty
  - loose, disconnected or deteriorated hoses of the evaporative emission control system

### Backfiring or misfiring acceleration

- Ignition system faulty
- Fuel mixture too lean

### Poor performance (driveability) and poor fuel economy

- Fuel system clogged
- Ignition malfunction
- Evaporative emission control system malfunction (U. S. A. Only)
  - PAIR control valve faulty
  - loose, disconnected or deteriorated hoses of the evaporative emission control system

### Lean mixture

- Fuel jets clogged
- Float valve faulty
- Float level too low
- Fuel line restricted
- Carburetor air vent hole (or tube) clogged
- U.S.A. Only: PAIR control valve faulty
- Intake air leak
- Fuel pump malfunction
- Vacuum piston faulty
- Throttle valve faulty

### Rich mixture

- Starting enrichment (SE) valve in ON position
- Float valve faulty
- Float level too high
- Air jets clogged
- Air cleaner contaminated
- Flooded carburetors

# Air Cleaner Housing Removal/Installation

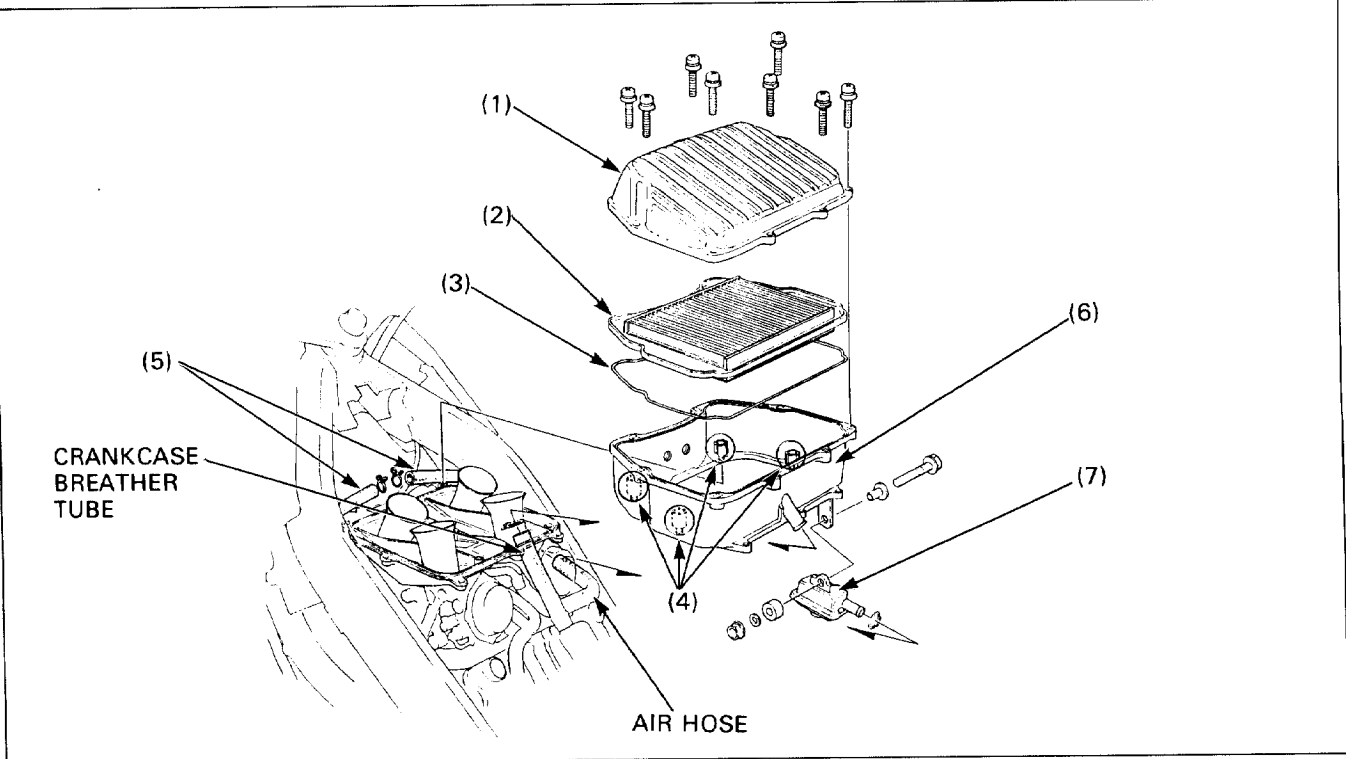

## Requisite Service

- Fuel tank removal/installation (page 2-22)

Procedure	Q'ty	Remarks
<b>Removal Order</b>		• Installation is in the reverse order of removal.
(1) Air cleaner housing cover	1	
(2) Air cleaner	1	
(3) O-ring	1	
(4) Air cleaner housing mounting screw	4	
(5) Air suction hose (No. 15)	2	U.S.A. only
(6) Air cleaner housing	1	Disconnect the crankcase breather tube from the air cleaner housing. Disconnect the air hose from the sub air cleaner housing.
(7) Sub air cleaner housing	1	Refer to page 3-6 for disassembly/assembly.

# Carburetor Removal/Installation

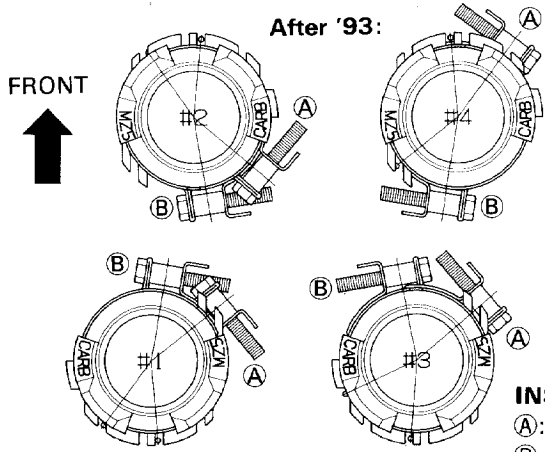
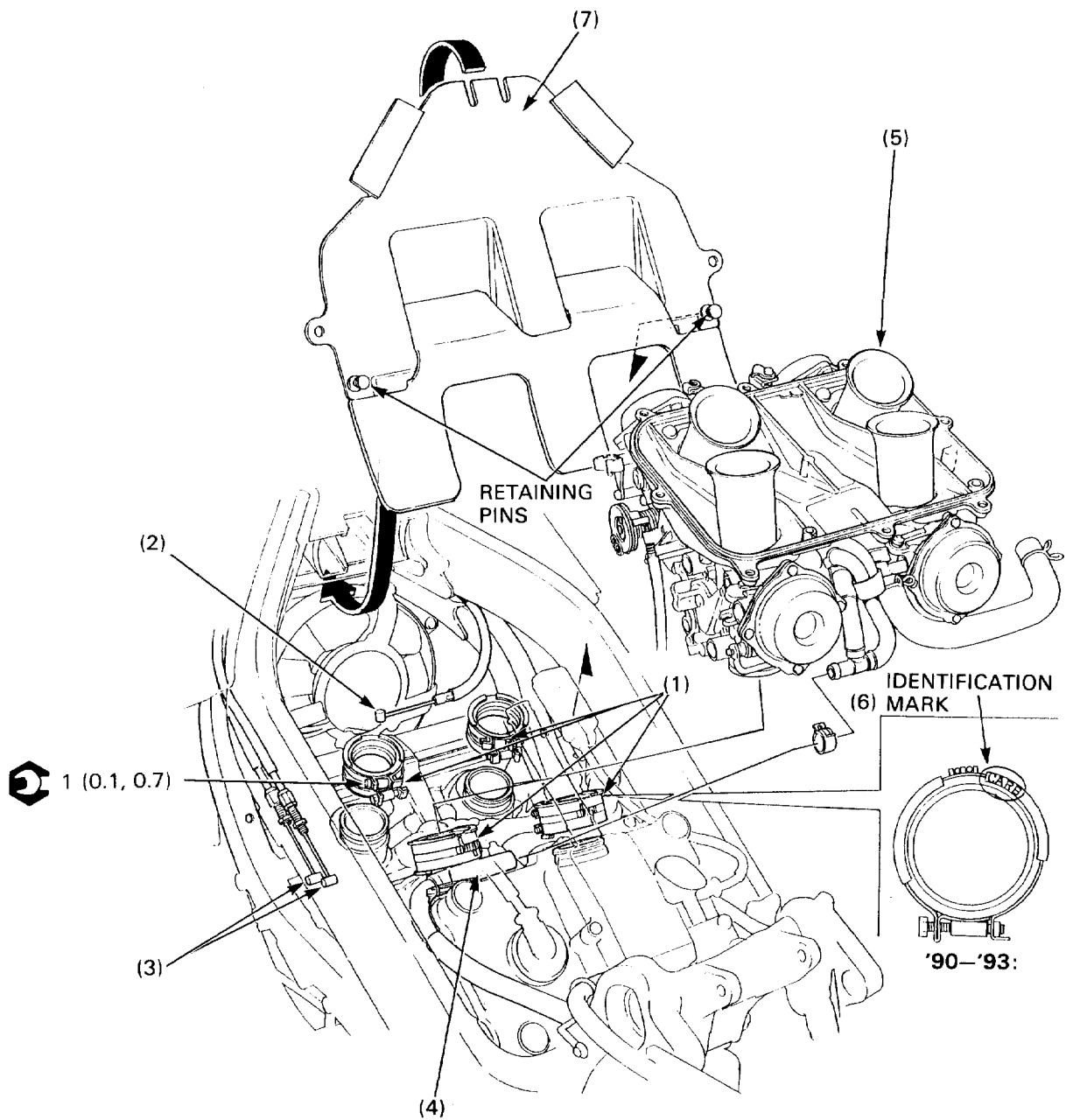

**INSULATOR BAND:**  
A: CARBURETOR SIDE  
B: CYLINDER HEAD SIDE

**▲ WARNING**

- Gasoline is extremely flammable and is explosive under certain conditions. Work in a well ventilated area. Smoking or allowing flames or sparks in the work area or where gasoline is stored can cause a fire or explosion.

**Requisite Service**

- Fuel tank removal/installation (page 2-22)
- Air cleaner housing removal/installation (page 6-3)
- Carburetors draining

Procedure		Q'ty	Remarks
	<b>Removal Order</b>		
(1)	Insulator band	4	<ul style="list-style-type: none"> <li>• Installation is in the reverse order of removal. Not necessary to remove, just loosen.</li> <li>After '93: Align the clamps as shown in the illustration before tightening.</li> </ul>
(2)	Choke cable	1	
(3)	Throttle cable	2	After installation, adjust throttle free play.
(4)	Fuel tube	1	
(5)	Carburetor assembly	1	
(6)	Insulator	4	Install them so that the screw heads facing outside and the identification mark "CARB" facing the carburetor as shown.
(7)	Heat guard	1	Install with the retaining pins pulled out fully, and secure it by pushing in the pins.

# Fuel Tank Disassembly/Assembly

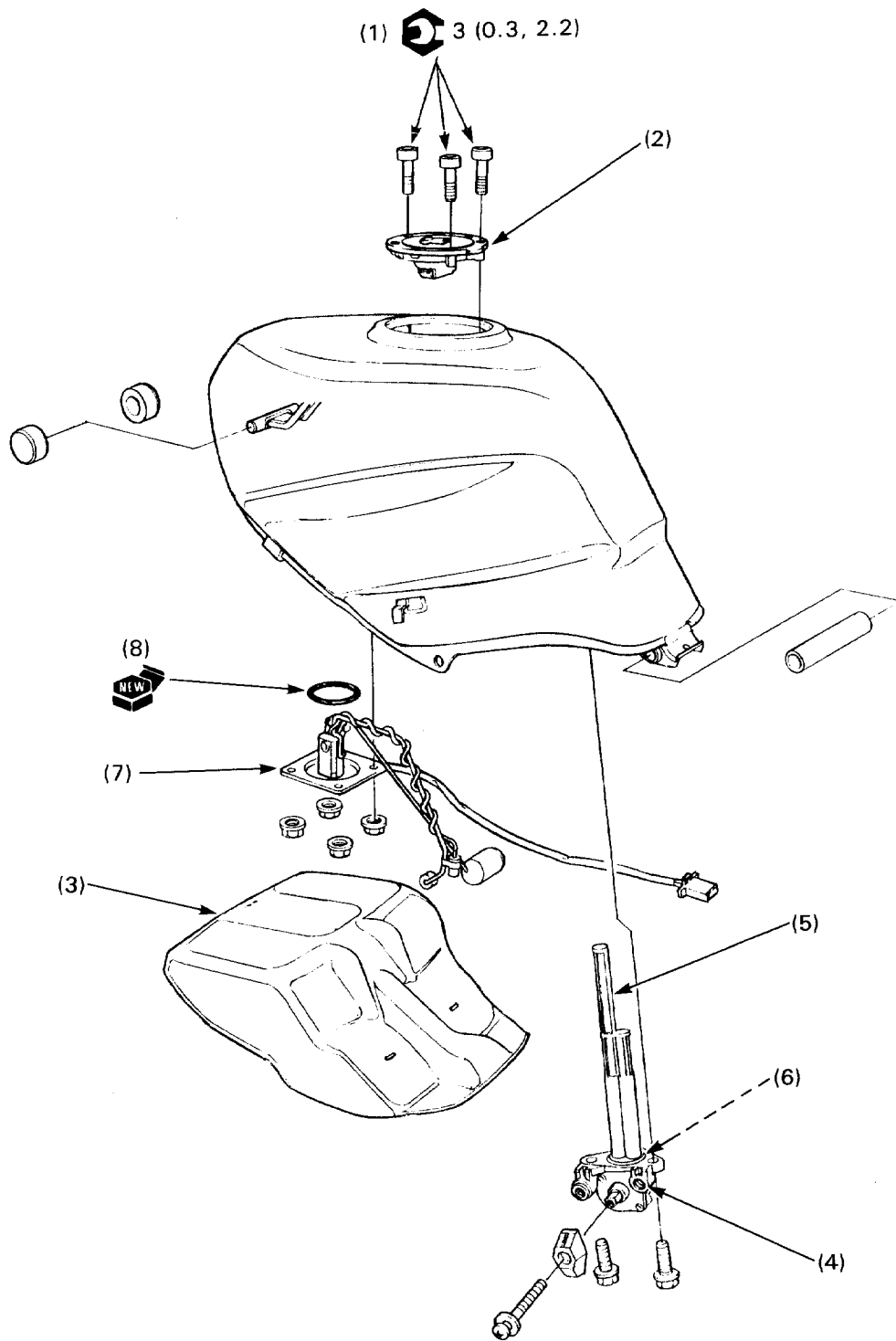

**▲ WARNING**

- Gasoline is extremely flammable and is explosive under certain conditions. Work in a well ventilated area. Smoking or allowing flames or sparks in the work area or where gasoline is stored can cause a fire or explosion.

**Requisite Service**

- Fuel tank removal/installation (page 2-22)

Procedure		Q'ty	Remarks
<b>Removal Order</b>			• Installation is in the reverse order of removal.
(1)	Fuel fill cap mounting bolt	3	
(2)	Fuel fill cap base	1	
(3)	Heat guard	1	When installing, align the slots in the guard with the claws on the fuel tank.
(4)	Fuel valve assembly	1	
(5)	Fuel filter	1	
(6)	O-ring	1	
(7)	Fuel level sensor	1	Inspection: Section 18.
(8)	O-ring	1	

# Carburetor Separation/Combination

('90-'93)

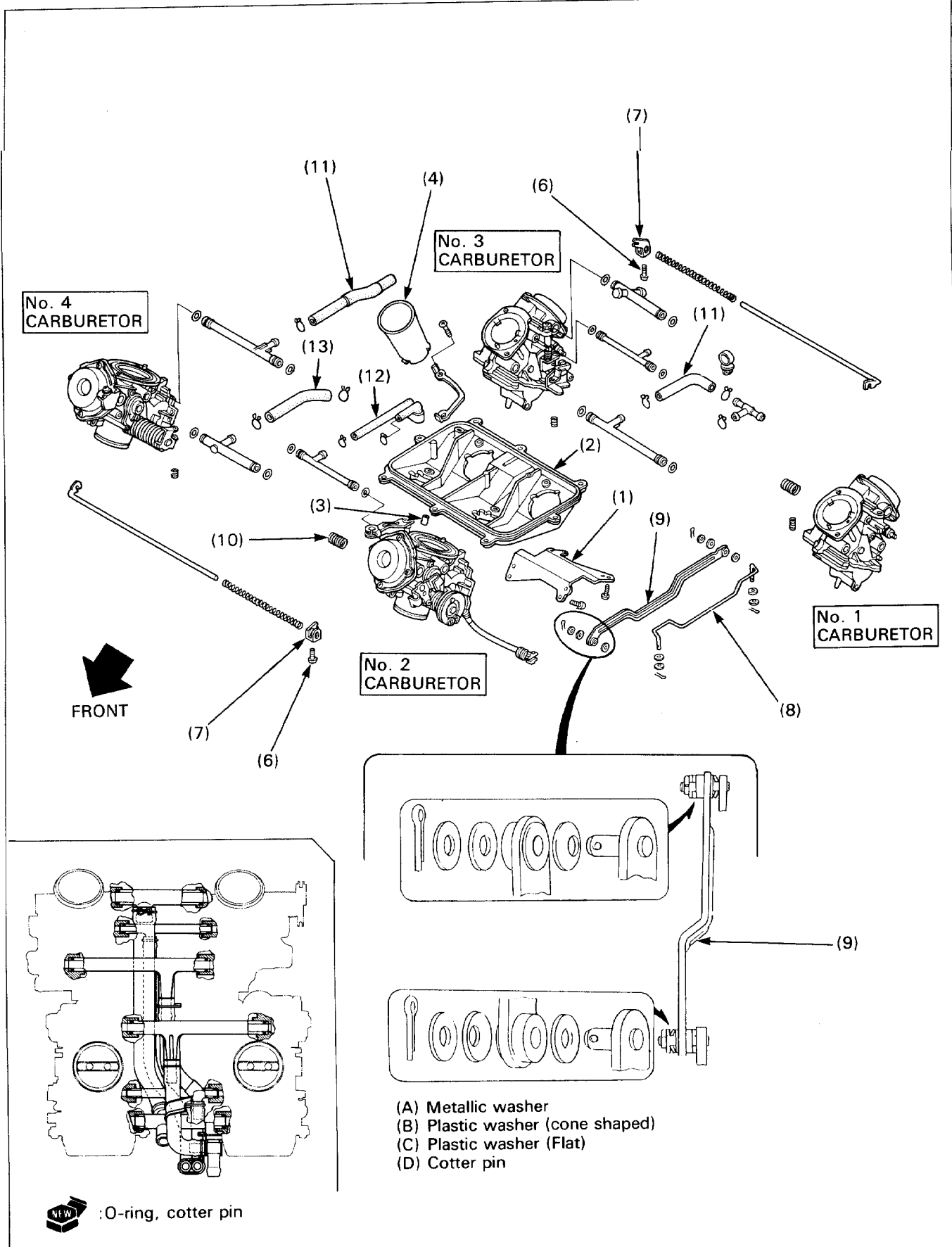

:O-ring, cotter pin

**WARNING**

- Gasoline is extremely flammable and is explosive under certain conditions. Work in a well ventilated area. Smoking or allowing flames or sparks in the work area or where gasoline is stored can cause a fire or explosion.

**CAUTION**

- After combining the carburetors, make sure the throttle link and starting enrichment link move smoothly, and close fully automatically.
- After combining the carburetors, make sure the starting enrichment valve is not pulled by the starting enrichment arm.

**Requisite Service**

- Carburetor removal/installation (page 6-4)
- Carburetor synchronization (page 3-11)

Procedure		Q'ty	Remarks
<b>Separation Order</b>			
(1)	Carburetor bracket	1	
(2)	Air chamber	1	Remove after raising up the locking plate tabs and unscrewing.
(3)	Dowel pin	16	
(4)	Air funnel	4	
(5)	O-ring	4	
(6)	Starting enrichment arm screw	2	Not necessary to remove, only loosen.
(7)	Starting enrichment arm	2	Release from the starting enrichment valves.
(8)	Starting enrichment link	1	
(9)	Throttle link	1	
(10)	Thrust spring	2	
(11)	Fuel tube	1	
(12)	Air vent tube	1	
(13)	Air hose	1	
<b>Combination Order</b>			
(8)	Starting enrichment link	1	Install the washers on the link correctly as shown.
(9)	Throttle link	1	
(13)	Air hose	1	Route and clamp correctly as shown.
(12)	Air vent tube	1	
(11)	Fuel tube	1	Be careful not to pinch the O-ring on the joint pipe.
(7)	Starting enrichment arm	1	
(5)	O-ring	4	Hook the arms on the starting enrichment valves. Align the tabs of the O-ring with the cut out in the carburetor.
(4)	Air funnel	4	Align the funnel setting tabs with the cut out in the carburetor.
(10)	Thrust spring	2	
(3)	Dowel pin	16	
(2)	Air chamber	1	Do not tighten the screws until the bracket screws are screwed in.
(1)	Carburetor bracket	1	Tighten the air chamber screws and bracket screws, and bend down the locking plate tabs.
(6)	Starting enrichment arm screw	2	

# Carburetor Separation

(After '93)

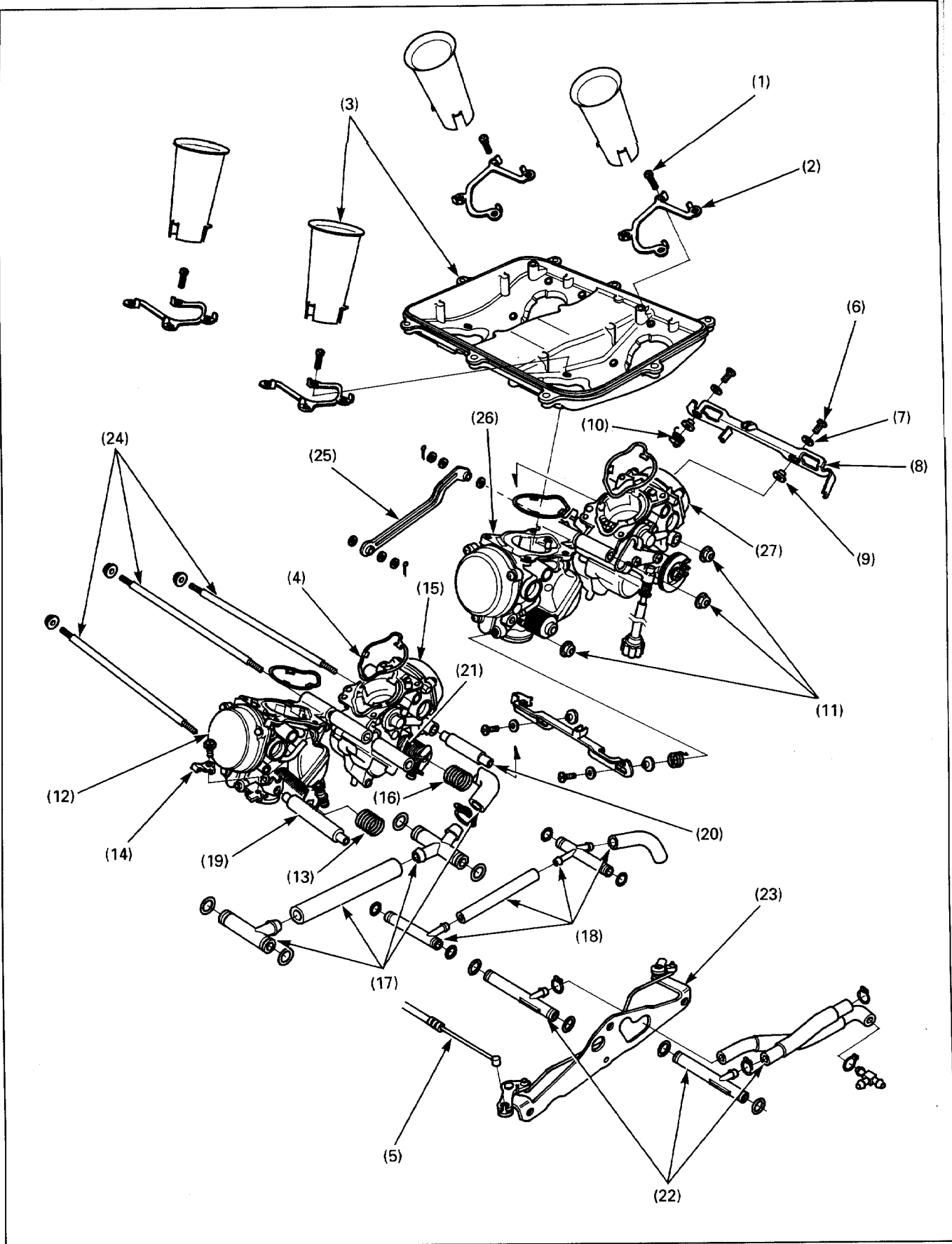

## Requisite Service

- Carburetor removal (page 6-4)

Procedure		Q'ty	Remarks
<b>Separate No. 4 carb. from No. 1/2/3 carb.</b>			
(1)	Air chamber screw	16	NOTE • Loosen the nuts gradually and alternately. • Do not remove the connecting bolts yet.
(2)	Lock plate	4	
(3)	Air chamber/air funnel	1/4	
(4)	O-ring	4	
(5)	Choke cable	1	
(6)	Starting enrichment arm screw	4	
(7)	Plastic washer	4	
(8)	Starting enrichment arm	2	
(9)	Plastic collar	4	
(10)	Return spring	2	
(11)	Carburetor connecting nut	6	
(12)	No. 4 carburetor	1	
(13)	Thrust spring	1	
(14)	Choke cable holder	1	
<b>Separate No. 3 carb. from No. 1/2 carb.</b>			
(15)	No. 3 carburetor	1	
(16)	Thrust spring	1	
(17)	Sub-air joint pipe/tube/O-ring	2/2/4	
(18)	Air vent joint pipe/tube/O-ring	2/2/4	
(19)	Front collared dowel pin	1	
(20)	Rear collared dowel pin	1	
(21)	Center collar	1	
(22)	Fuel tube/joint pipe	2/3	
(23)	Starting enrichment link assembly	1	
<b>Separate No. 2 carb. from No. 1 carb.</b>			
(24)	Carburetor connecting bolt	3	
(25)	Throttle link	1	
(26)	No. 2 carburetor	1	
(27)	No. 1 carburetor	1	

# Carburetor Combination

(After '93)

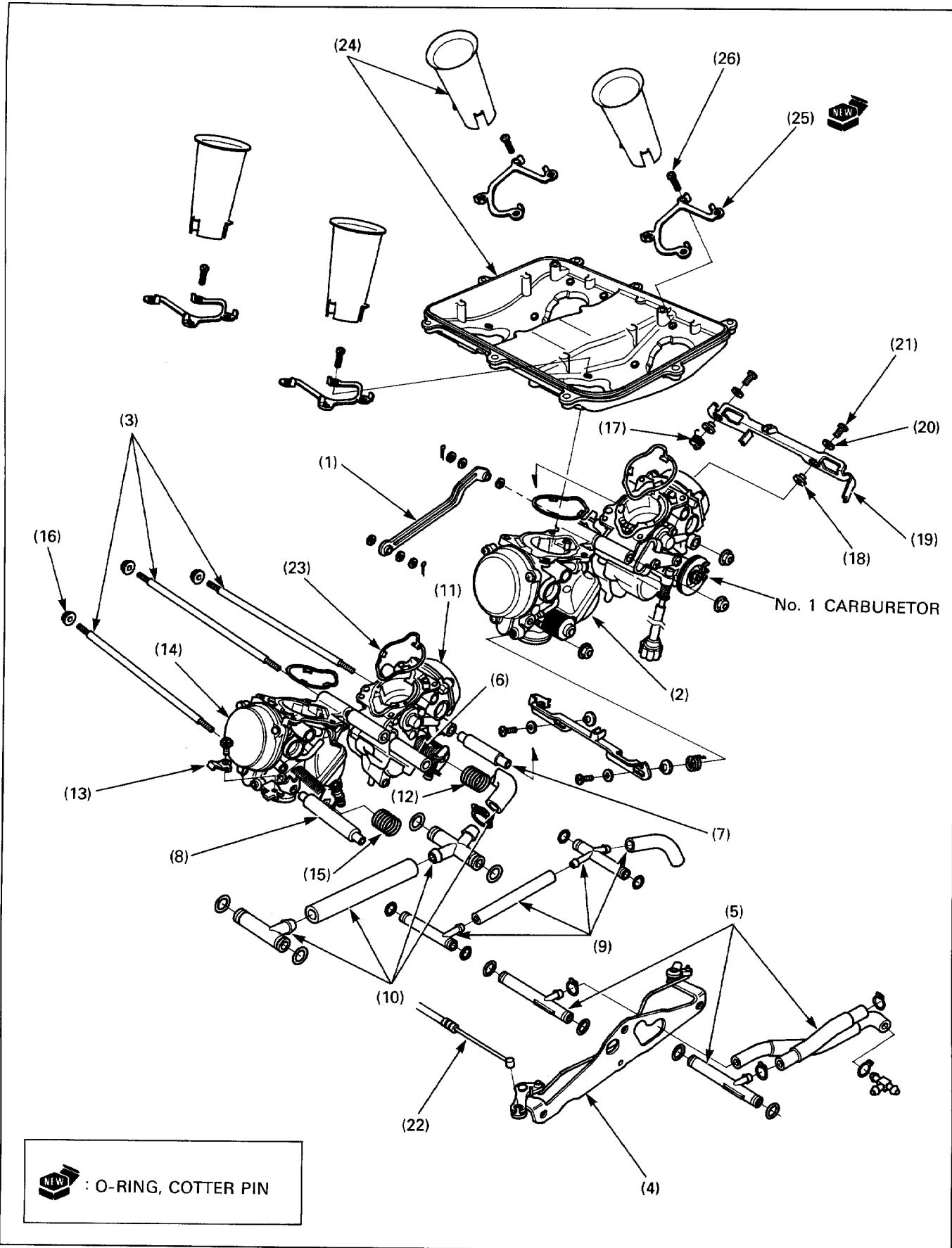

## NOTE

- No. 1 carburetor is the base carburetor.
- Before tightening the connecting nuts, be sure there is no clearance at the joint of the carburetors.
- Tighten the connecting nuts alternately and gradually. Position the connecting bolt so that it projects an equal amount on the left and right ends, then tighten one nut while holding another.

## Requisite Service

- Carburetor installation (page 6-4)
- Carburetor synchronization (page 3-11)

	Procedure	Q'ty	Remarks	
	<b>Assemble No. 2 carb. with No. 1 carb.</b>			
(1)	Throttle link	1	Refer to the drawing for the combination of the washer.	
(2)	No. 2 carburetor	1		
(3)	Carburetor connecting bolt	3		
	<b>Assemble No. 3 carb. with No. 1/2 carb.</b>			
(4)	Starting enrichment link assembly	1		
(5)	Fuel tube/joint pipe/O-ring	2/3/6		
(6)	Center collar	1		
(7)	Rear collared dowel pin	1		
(8)	Front collared dowel pin	1		
(9)	Air vent joint pipe/tube/O-ring	2/2/4		
(10)	Sub-air joint pipe/tube/O-ring	2/2/4		
(11)	No. 3 carburetor	1		
(12)	Thrust spring	1		
	<b>Assemble No. 4 carb. with No. 1/2/3 carb.</b>			
(13)	Choke cable holder	1		<b>CAUTION</b> • Tighten each nut gradually and alternately using the procedure in the NOTE above. Do not over-tighten the nuts.  NOTE • After '94 : Shorter stacks toward front. <b>NEW</b>
(14)	No. 4 carburetor	1		
(15)	Thrust spring	1		
(16)	Carburetor connecting nut	6		
(17)	Return spring	2		
(18)	Plastic collar	4		
(19)	Starting enrichment arm	2		
(20)	Plastic washer	4		
(21)	Starting enrichment arm screw	4		
(22)	Choke cable	1		
(23)	O-ring	4		
(24)	Air chamber	1		
(25)	Air funnel	4		
(26)	Lock plate	4		
(27)	Air chamber screw	16		

Carburetor Tube Routing (After '93)

49 state/Canada type:

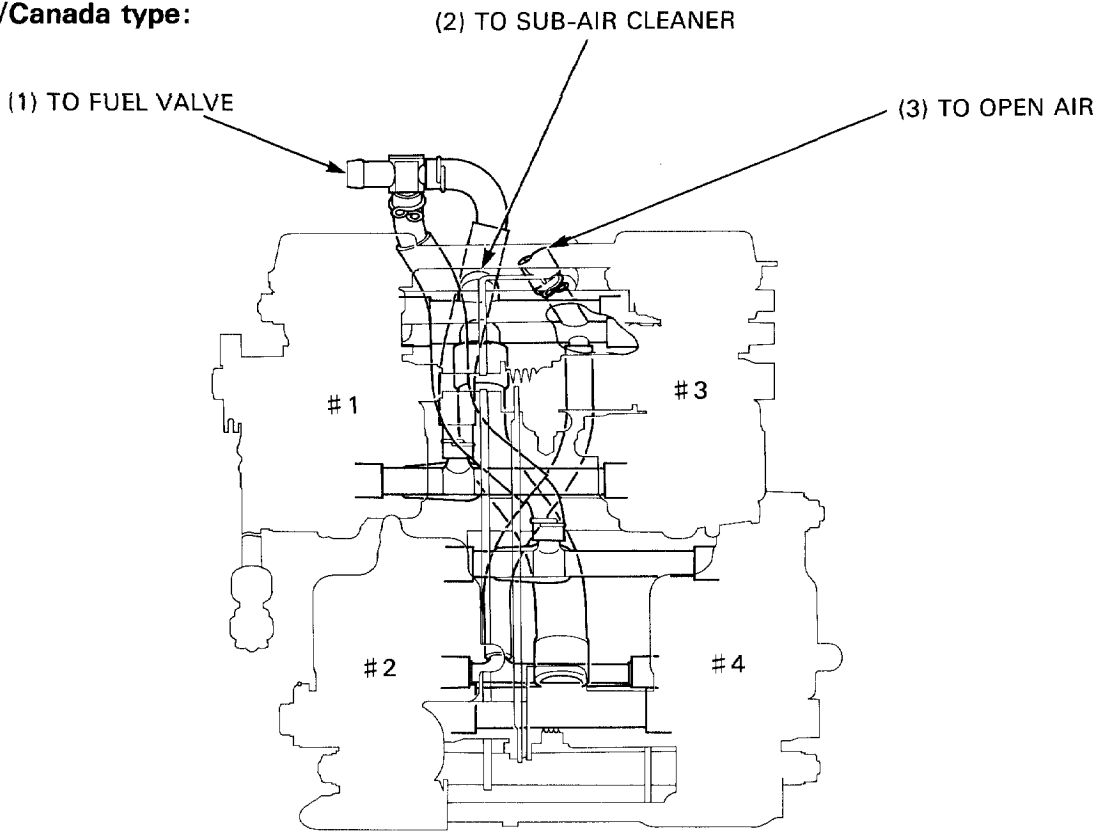

California type:

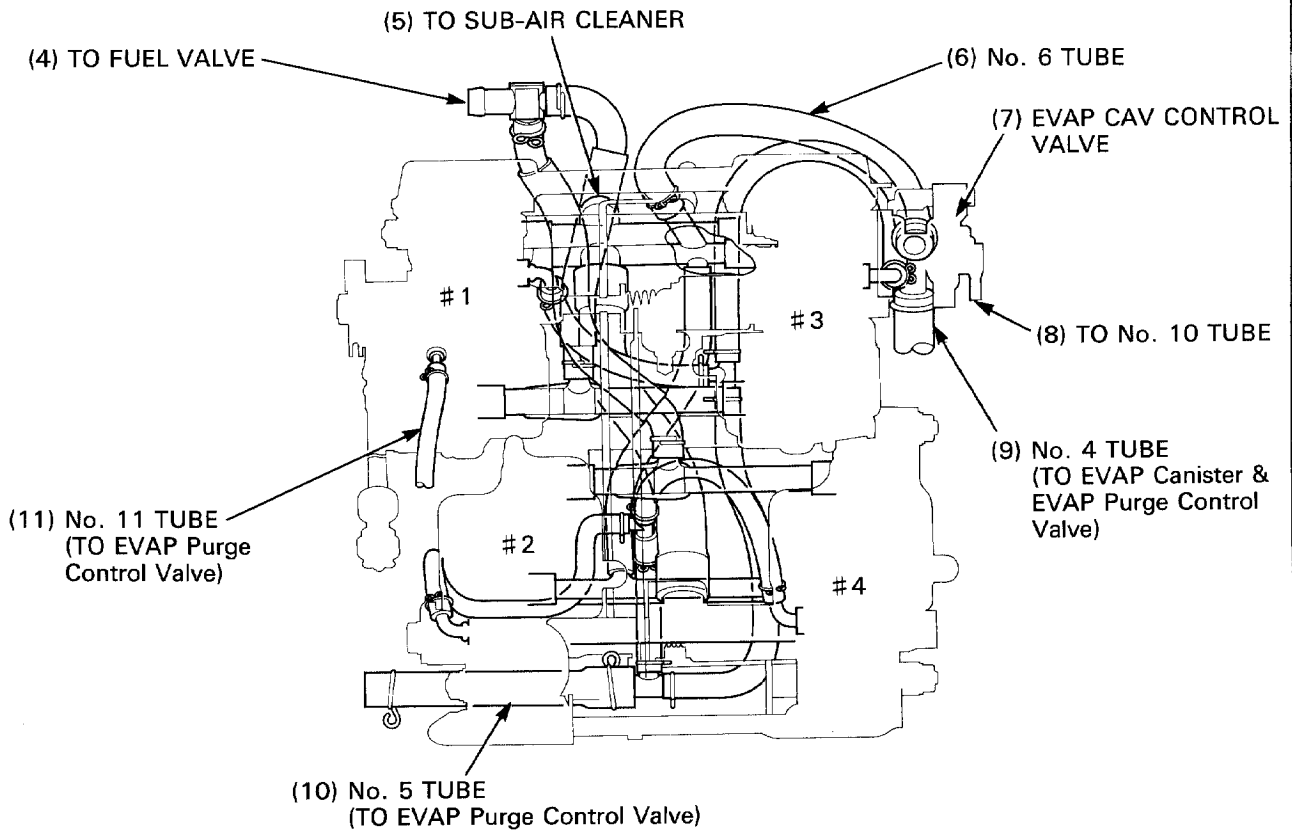



# Carburetor Disassembly/Assembly

'90-'93:

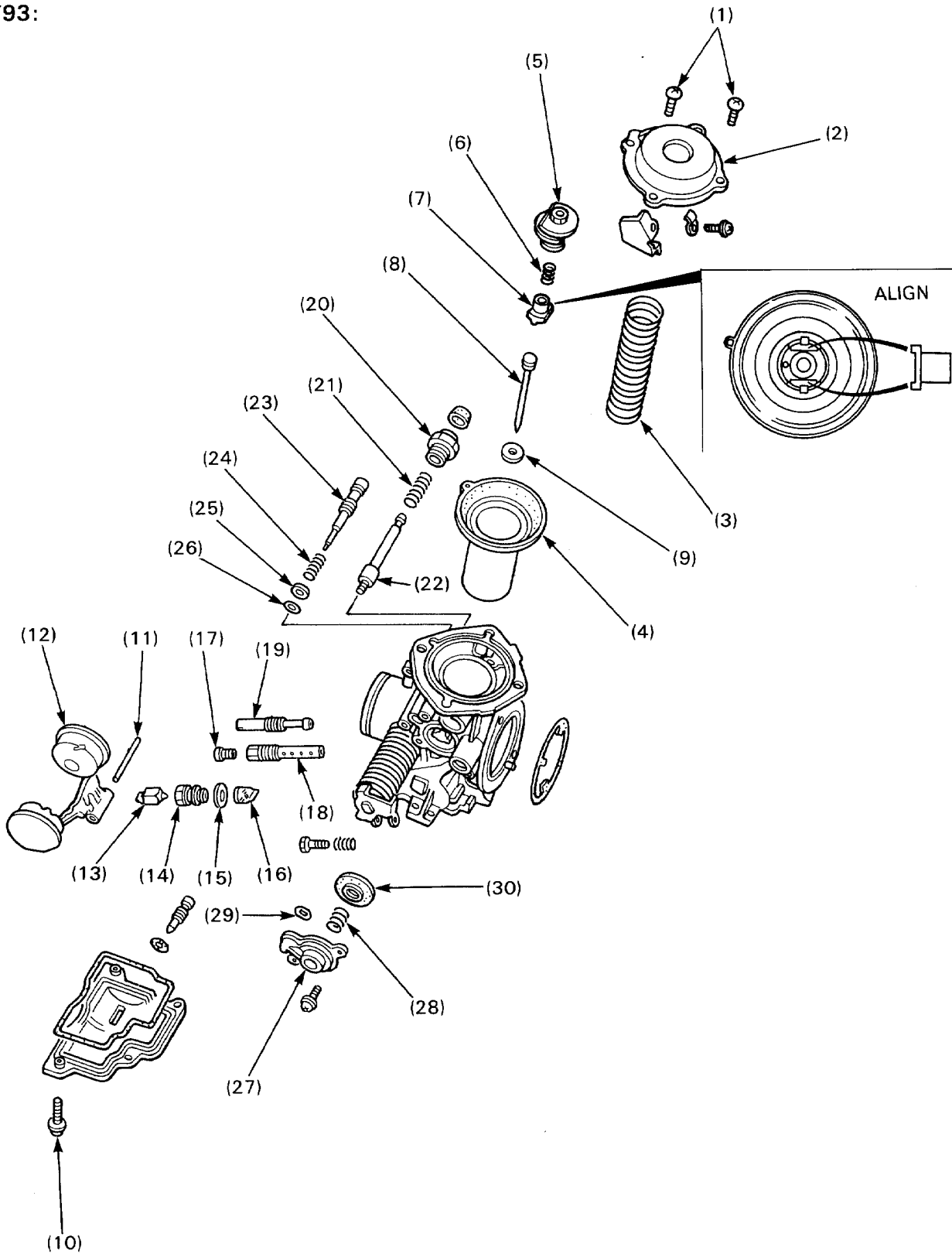

 : O-ring

**CAUTION**

- Damage to the pilot screw seat will occur if the pilot screw is tightened against the seat.

**NOTE**

- The vacuum chamber and float chamber can be serviced with the carburetors assembled.
- The pilot screws are factory pre-set and should not be removed unless the carburetors are overhauled. Turn each pilot screw in and carefully count the number of turns before it seats lightly. Make a note of this to use as a reference when reinstalling the pilot screws. If new pilot screws are installed, turn pilot screws out to the initial opening (page 6-21).

**Requisite Service**

- Fuel tank removal/installation (page 2-22)
- Air cleaner housing removal/installation (page 6-3)
- Carburetor removal/installation (page 6-4)
- Carburetor separation/combination (page 6-8)
- Carburetor synchronization (page 3-11)

Procedure		Q'ty	Remarks
<b>Disassembly Order</b>			• Assembly is in the reverse order of disassembly.
<b>Vacuum Chamber</b>			
(1)	Vacuum chamber cover screws	4	At installation, first tighten the two screws on the dowel pin side.
(2)	Vacuum chamber cover	1	
(3)	Spring	1	
(4)	Diaphragm/vacuum piston	1	
(5)	Jet needle holder	1	Turn the holder 90°counterclockwise while pushing it in and remove it.
(6)	Spring	1	
(7)	Spring holder	1	At installation, align holder claws with piston grooves.
(8)	Jet needle	1	
(9)	Washer	1	
<b>Float Chamber</b>			
(10)	Float chamber cover screws	4	At installation, first tighten the two screws on the dowel pin side.
(11)	Float pin	1	
(12)	Float	1	For float level inspection, refer to the section 8 of the Common Service Manual.
(13)	Float valve	1	
(14)	Valve seat	1	
(15)	Sealing washer	1	
(16)	Fuel filter	1	
(17)	Main jet	1	
(18)	Needle jet	1	
(19)	Slow jet	1	
<b>Starting Enrichment (SE) Valve</b>			
(20)	Valve nut	1	
(21)	Spring	1	
(22)	SE valve	1	
<b>Pilot Screw</b>			
(23)	Pilot screw	1	
(24)	Spring	1	
(25)	Washer	1	
(26)	O-ring	1	
<b>Air cut off valve</b>			
(27)	Air cut off valve cover	1	
(28)	Spring	1	
(29)	O-ring	1	Install with the flat side facing carburetor.
(30)	Diaphragm	1	Be careful not to pinch with the cut off valve cover.

After '93:

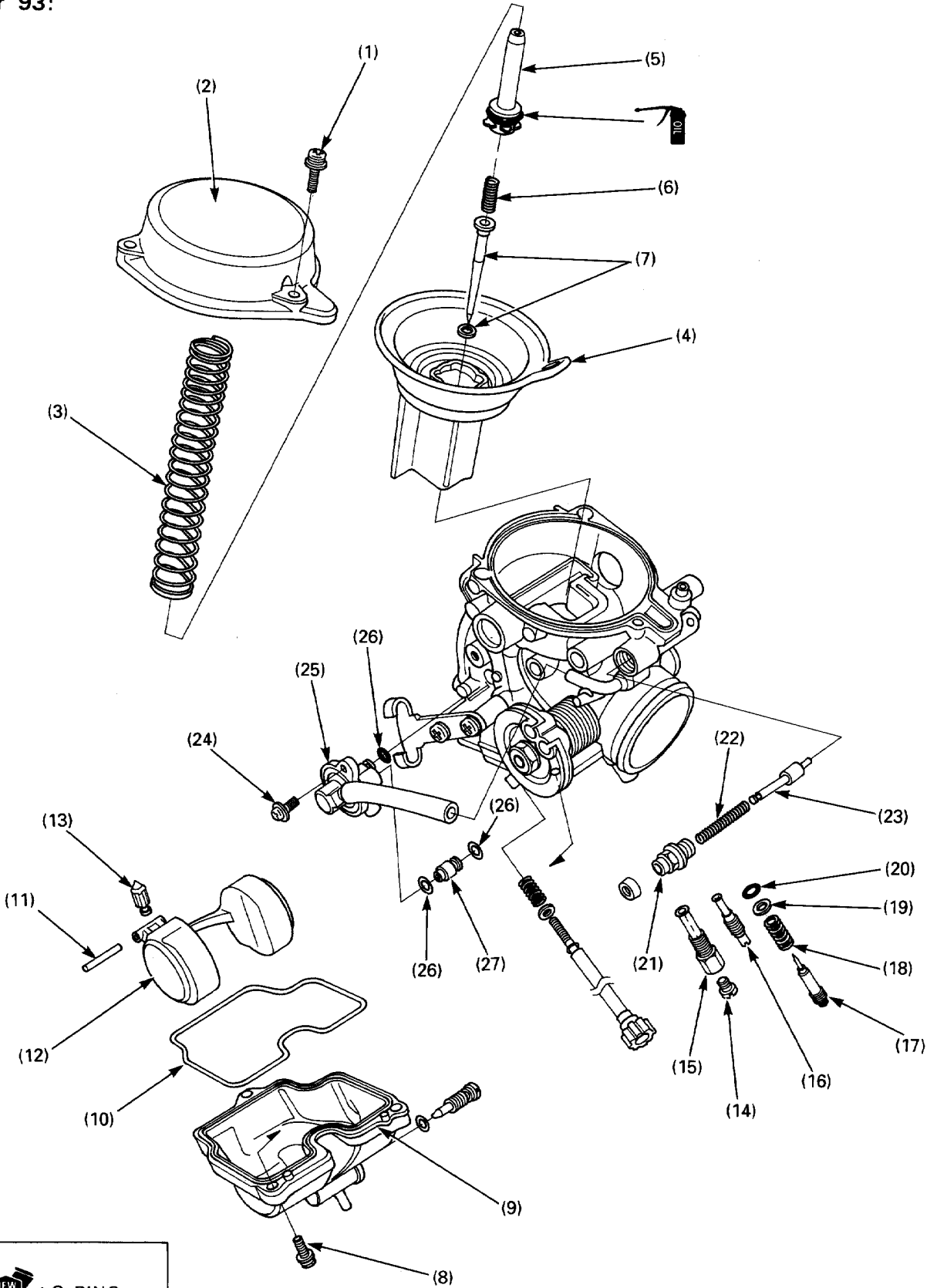

 : O-RING

NOTE

- Vacuum chamber, float chamber and jets can be serviced without separating the carburetors.
- Keep each carburetor's parts separate from the other's so you can install the parts in their original positions.

**Requisite Service**

• Carburetor separation (page 6-10)

• Carburetor combination (page 6-12)

Procedure	Q'ty	Remarks
<p><b>Disassembly Order</b></p> <p><b>Vacuum Chamber</b></p> <p>(1) Vacuum chamber cover screw</p> <p>(2) Vacuum chamber cover</p> <p>(3) Diaphragm spring</p> <p>(4) Diaphragm/vacuum piston</p> <p>(5) Jet needle holder</p> <p>(6) Jet needle holder spring</p> <p>(7) Jet needle/washer</p>	<p>3</p> <p>1</p> <p>1</p> <p>1</p> <p>1</p> <p>1</p> <p>1</p> <p>1/1</p>	<p>Assembly is in the reverse order of disassembly.</p> <p>NOTE</p> <ul style="list-style-type: none"> <li>• At installation, be careful not to damage the spring.</li> </ul> <p>NOTE</p> <ul style="list-style-type: none"> <li>• At installation, align the tab of the diaphragm with the carburetor body groove.</li> </ul> <p>Removal/installation (page 6-20)</p>
<p><b>Float Chamber</b></p> <p>(8) Float chamber cover screw</p> <p>(9) Float chamber</p> <p>(10) O-ring</p> <p>(11) Float pin</p> <p>(12) Float</p> <p>(13) Float valve</p> <p>(14) Main Jet</p> <p>(15) Needle jet holder</p> <p>(16) Slow jet</p> <p>(17) Pilot screw</p> <p>(18) Spring</p> <p>(19) Washer</p> <p>(20) O-ring</p>	<p>3</p> <p>1</p> <p>1</p> <p>1</p> <p>1</p> <p>1</p> <p>1</p> <p>1</p> <p>1</p> <p>1</p> <p>1</p> <p>1</p> <p>1</p> <p>1</p>	
<p><b>Starting Enrichment (SE) Valve</b></p> <p>(21) Valve nut</p> <p>(22) Spring</p> <p>(23) SE valve</p>	<p>4</p> <p>1</p> <p>1</p>	
<p><b>Air Cut Off Valve</b></p> <p>(24) Air cut off valve cover screw</p> <p>(25) Air cut off valve cover</p> <p>(26) O-ring</p> <p>(27) Air cut off valve</p>	<p>1</p> <p>1</p> <p>3</p> <p>1</p>	<p>At installation, be sure the diaphragm and spring are properly seated, then tighten them.</p> <p>At installation, install the new O-ring with its flat side toward the carburetor body.</p>

## Jet Needle Holder Removal/Installation (After '93)

### Removal

Remove the vacuum piston (page 6-18).

Temporarily install a 4 mm screw or equivalent (Example; vacuum chamber screw).

Pull the screw and remove the jet needle holder.

### CAUTION

- Be careful not to damage the diaphragm.
- Do not remove the jet needle holder by pushing the jet needle.

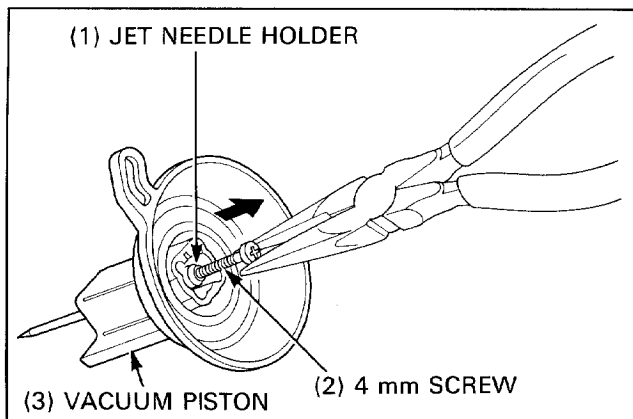

### Installation

Install the jet needle holder into the vacuum piston until you felt the click.

Install the vacuum piston (page 6-18)

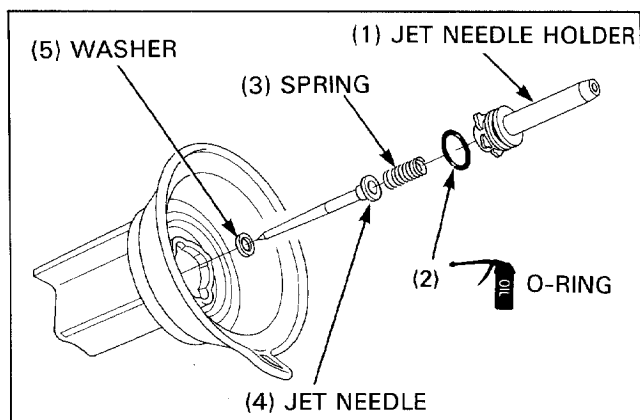

## Carburetor Body Cleaning

Clean the fuel strainer in the float valve using compressed air from the float valve seat side.

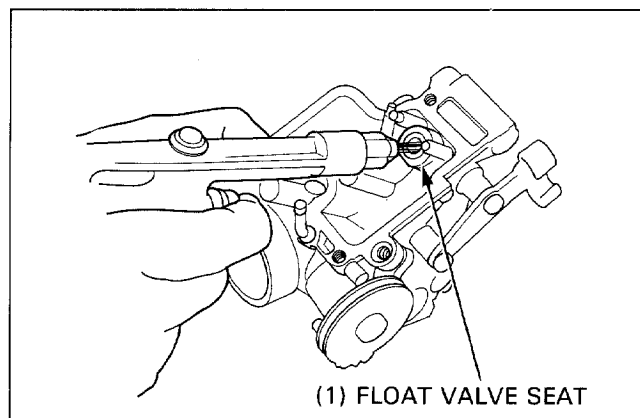



# Pilot Screw Adjustment

## Idle Drop Procedure

'90-'93:

**▲ WARNING**

- If the engine must be running to do some work, make sure the area is well ventilated. Never run the engine in an enclosed area. The exhaust contains poisonous carbon monoxide gas that may cause loss of consciousness and lead to death.

**NOTE**

- Make sure the carburetor synchronization is within specification before pilot screw adjustment (page 3-11).
- The pilot screws are factory pre-set and no adjustment is necessary unless the pilot screws are replaced.
- Use a tachometer with graduations of 50 rpm change.

1. Turn each pilot screw clockwise until it seats lightly, then back it out to the specification given.

**CAUTION**

- Damage to the pilot screw seat will occur if the pilot screw is tightened against the seat.

This is an initial setting prior to the final pilot screw adjustment.

- Initial Opening:** 49 states type '90-'91: 1-1/2 turns out  
 '92-'93: 1-7/8 turns out  
 California type '90-'91: 2-1/2 turns out  
 '92-'93: 2 turns out  
 Canada type '90-'91: 2-1/4 turns out  
 '92-'93: 1-7/8 turns out

2. Warm up the engine to operating temperature. Stop and go riding for 10 minutes is sufficient.
3. Attach a tachometer according to its manufacturer's instructions.
4. Adjust the idle speed to the specified rpm with the throttle stop screw.

**Idle Speed:** 49 state/Canada type: 1,000±100 rpm  
 California type: 1,200±100 rpm

5. Turn all pilot screws 1/2 turn counterclockwise from the initial setting.
6. If the engine speed increases by 50 rpm or more, turn all pilot screws out by successive 1/2 turn increments until engine speed does not increase.
7. Adjust the idle speed with the throttle stop screw.
8. Turn the No.2 carburetor pilot screw in until the engine speed drops 50 rpm.
9. Then turn the No.2 carburetor pilot screw counterclockwise 1/8 turn from the position obtained in step 8.
10. Adjust the idle speed with the throttle stop screw.
11. Perform steps 8,9 and 10 for the No.1,3 and 4 carburetor pilot screws.
12. U.S.A. only: Apply Loctite 601 or equivalent to the inside of the limiter caps. Place the caps over the pilot screws so that they can be turned clockwise only. This will prevent adjustment in the counterclockwise direction which richens the fuel mixture.

**NOTE**

- Be careful not to turn the pilot screw when installing the limiter cap.

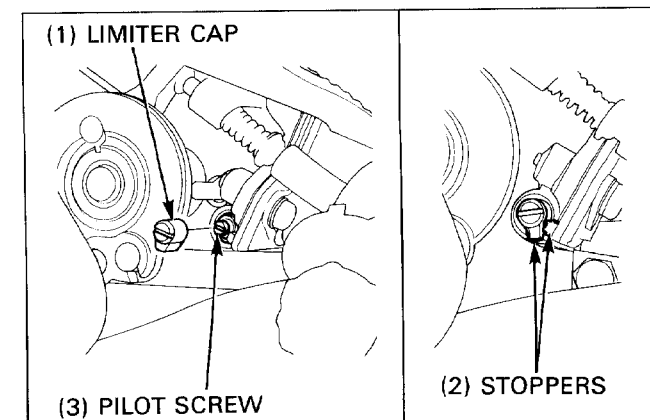
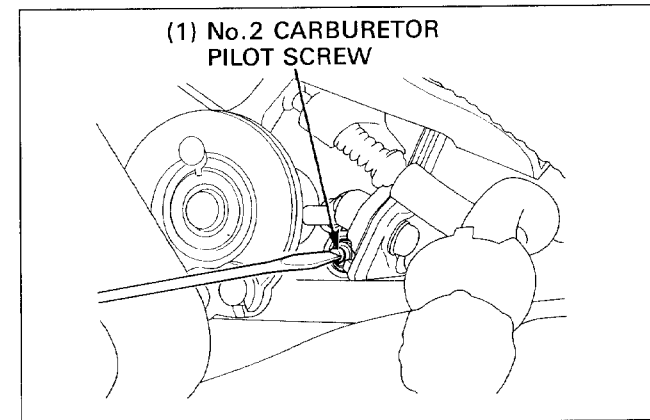
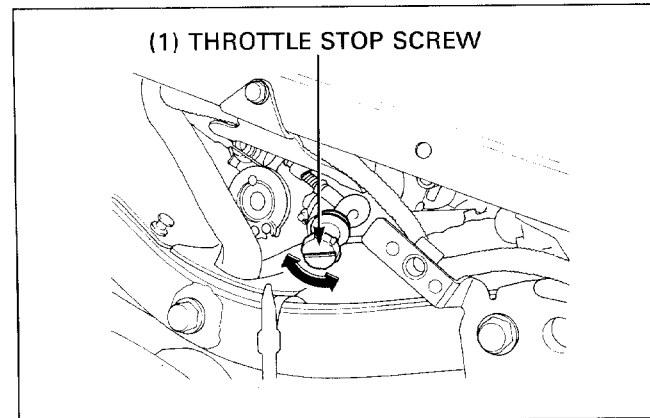
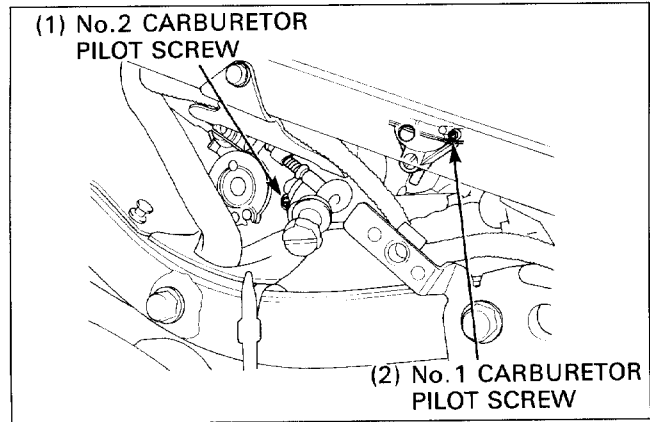

After '93:

**⚠ WARNING**

- If the engine must be running to do some work, make sure the area is well-ventilated. Never run the engine in an enclosed area. The exhaust contains poisonous carbon monoxide gas that may cause loss of consciousness and may lead to death.

NOTE

- Make sure the carburetor synchronization is within specification before pilot screw adjustment (page 3-11).
- The pilot screw is factory pre-set and no adjustment is necessary unless the pilot screw is replaced.
- Use a tachometer with graduations of 50 rpm change.

1. Turn the pilot screw clockwise until seats lightly, then back it out to the specification given. This is an initial setting prior to the final screw adjustment.

**CAUTION**

- Damage to the pilot screw seat will occur if the pilot screw is tightened against the seat.

**S TOOL**

Pilot screw wrench

**49 state/California type:** 07KMA-MS60101 and 07PMA-MZ20110  
**Canada type:** 07908-4220201

**Initial Opening:** **49 state type:** 1-5/8 turns out  
**California type:** 2-3/8 turns out  
**Canada type:** 1-3/8 turns out

2. Warm up the engine to operating temperature.
3. Attach the tachometer according to the tachometer manufacturer's instructions.
4. Adjust the idle speed to the specified rpm with the throttle stop screw knob.

**Idle Speed:** **49 state type:** 1,100±100 rpm  
**California type:** 1,200±100 rpm  
**Canada type:** 1,000±100 rpm

5. Turn each pilot screw 1/2 turn out from the initial setting.
6. If the idle speed increases by 50 rpm or more, turn each pilot screw out by successive 1/2 turn increments until engine speed does not increase.
7. Adjust the idle speed with the throttle stop screw knob.
8. Turn the No. 1 carburetor pilot screw in until the engine speed drops 50 rpm.
9. Turn the No.1 carburetor pilot screw out 1/4 turn from the position obtained in step 8.
10. Adjust the idle speed with the throttle stop screw knob.
11. Perform steps 8, 9 and 10 for the No.2, 3 and 4 carburetor pilot screws.

**49 state/California types:**

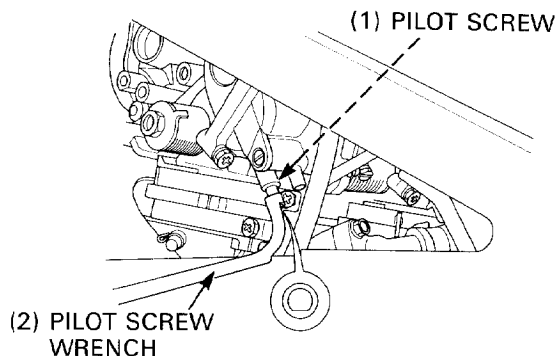

**Canada type:**

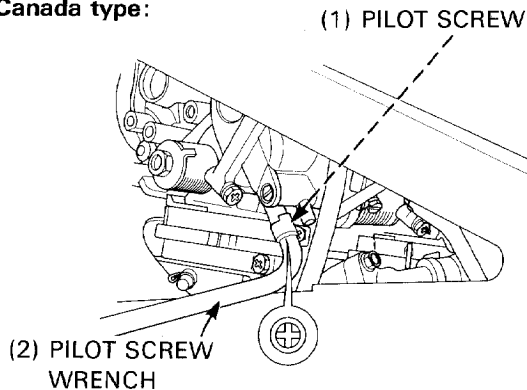

**(1) THROTTLE STOP SCREW KNOB**

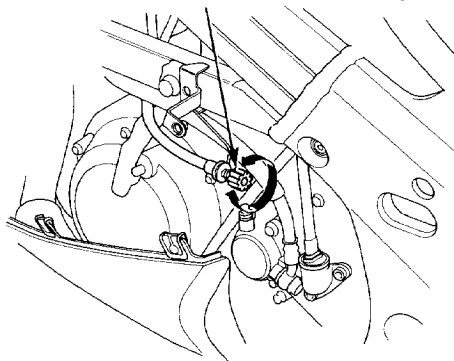

## High Altitude Adjustment (U.S.A. Only)

When the vehicle is to be operated continuously above 2,000 m (6,500 feet), the carburetor must be readjusted as follows to improve driveability and decrease exhaust emissions.

Warm up the engine to operating temperature. Stop and go riding for 10 minutes is sufficient.

Turn each pilot screw clockwise 1/2 turn.

Adjust the idle speed with the throttle stop screw.

### Idle Speed:

('90-'93)

49 state/Canada type: 1,000 ± 100 rpm

California type: 1,200 ± 100 rpm

(After '93)

49 state type: 1,100 ± 100 rpm

California type: 1,200 ± 100 rpm

Canada type: 1,000 ± 100 rpm

High Altitude Setting: 1/2 turn in

### NOTE

- This adjustment must be made at high altitude to ensure proper high altitude operation.

Attach a Vehicle Emission Control Information Update Label onto the rear fender beneath the seat as shown in the label position illustration.

### NOTE

- Do not attach the label to any part that can be easily removed from the vehicle.

### ⚠ WARNING

- Sustained operation at an altitude lower than 1,500 m (5,000 feet) with the carburetors adjusted for high altitude may cause the engine to idle roughly stall in traffic. It may also cause engine damage due to overheating.

When the vehicle is to be operated continuously below 1,500 m (5,000 feet), turn each pilot screw counter-clockwise 1/2 turn to its original position and adjust the idle speed.

### Idle Speed:

('90-'93)

49 state/Canada type: 1,000 ± 100 rpm

California type: 1,200 ± 100 rpm

(After '93)

49 state type: 1,100 ± 100 rpm

California type: 1,200 ± 100 rpm

Canada type: 1,000 ± 100 rpm

Be sure to make these adjustments at low altitude.

Remove the Vehicle Emission Control Information Update Label that is attached to the rear fender beneath the seat after adjusting for low altitude.

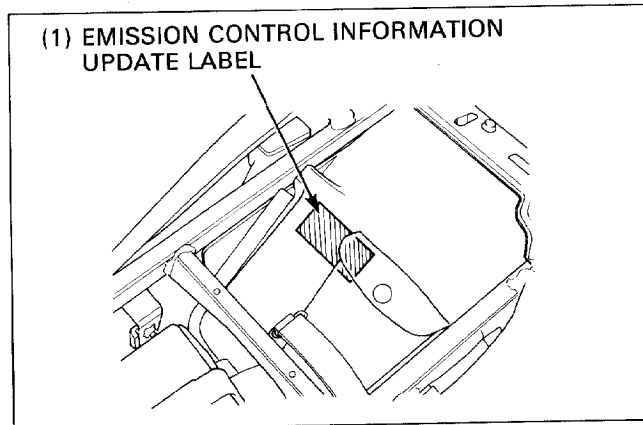
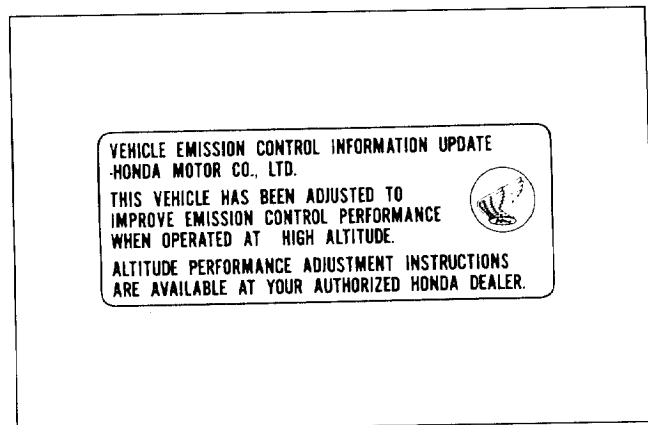
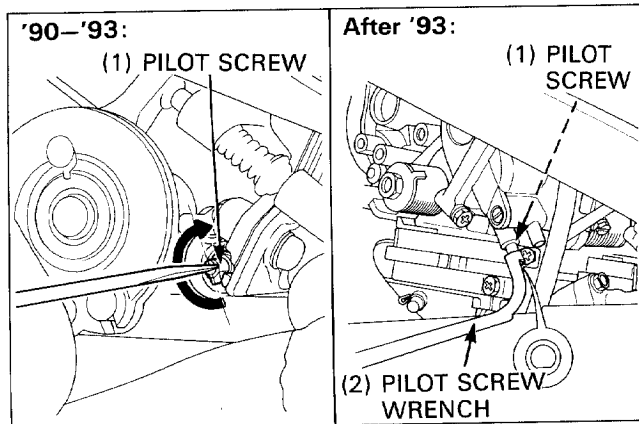

'91-'93 shown

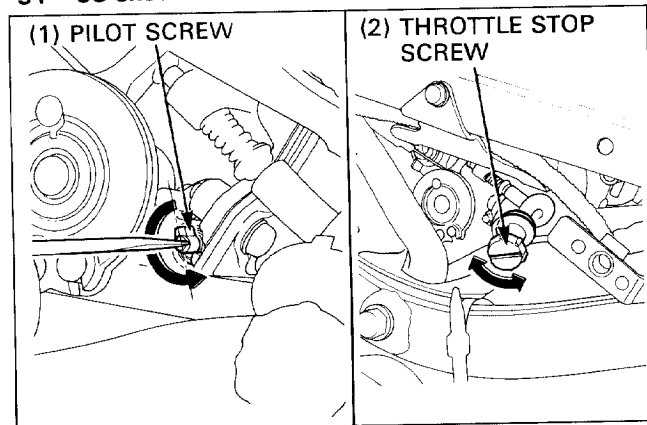

## Secondary Air Supply System (U.S.A. Only)

### Pulse Secondary Air Injection (PAIR) Control Valve

#### CAUTION

- To prevent damage to the PAIR control valve, do not use high air pressure sources. Use a hand operated air pump only

#### Front Bank

Remove the lower fairing (page 2-7).

Disconnect and remove the following:

- air intake hose
- vacuum tube
- PAIR control valve mounting bolt

Remove the air injection pipe mounting bolts and pipes.

Remove the PAIR control valve assembly.

#### Rear Bank

Remove the lower fairing (page 2-7).

Remove the fuel tank (page 2-22).

Remove the PAIR control valve following the removal procedure of the front bank.

#### Installation

Install new gaskets on the air injection pipe joint.

Install the removed parts in the reverse order of removal.

After installing, check the tubes for loose connections and kinks.

Install the following:

- lower fairing (page 2-7)
- fuel tank (page 2-22)

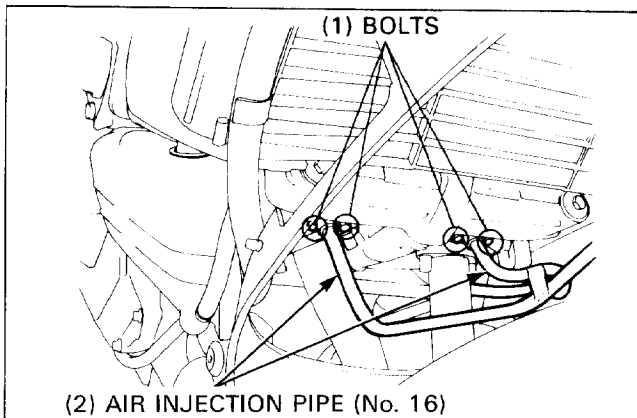
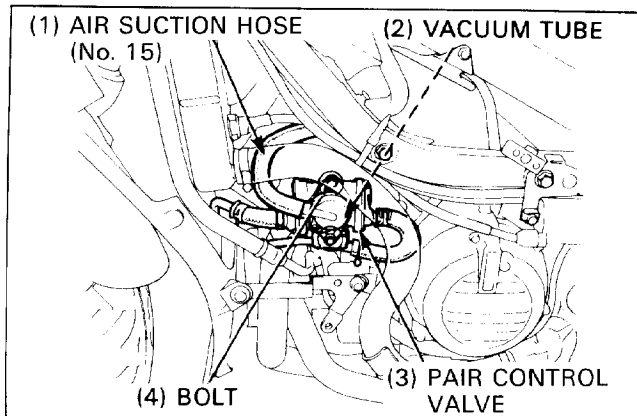

### Evaporative Emission (EVAP) Canister Removal/Installation

Remove the lower fairing (page 2-7).

Disconnect the No. 1 and No. 4 tubes.

Remove the bolts and EVAP canister.

Installation is in the reverse order of removal.

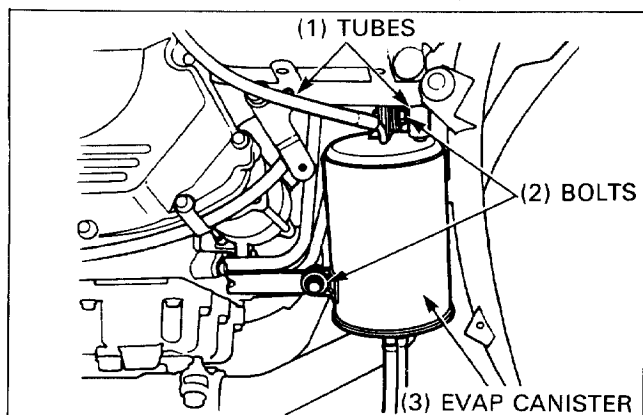



# 7. Engine Removal/Installation

Service Information	7-1	Engine Mounting Bolt Installation	7-4
Engine Removal/Installation	7-2		

## Service Information

- A floor jack or other support is required to support and maneuver the engine.
- When removing/installing the engine, tape the frame around the engine beforehand to protect the frame.
- During engine removal/installation, be careful not to damage the wire harnesses or cables by pinching them between the engine and frame.

### CAUTION

- Do not use the oil filter as a jack point.

7

- The following components can be serviced with the engine installed in the frame:
  - alternator (Section 15)
  - camshaft (Section 8)
  - carburetors (Section 6)
  - clutch (Section 9)
  - gearshift linkage (Section 10)
  - oil pump (Section 4)
  - ignition pulse generator (Section 16)
  - starter clutch (Section 17)
  - starter motor (Section 17)
  - water pump (Section 5)
- The following components require engine removal for service:
  - connecting rod (Section 11)
  - crankshaft (Section 11)
  - cylinder (Section 11)
  - cylinder head (Section 8)
  - piston (Section 11)
  - transmission (Section 11)

# Engine Removal/Installation

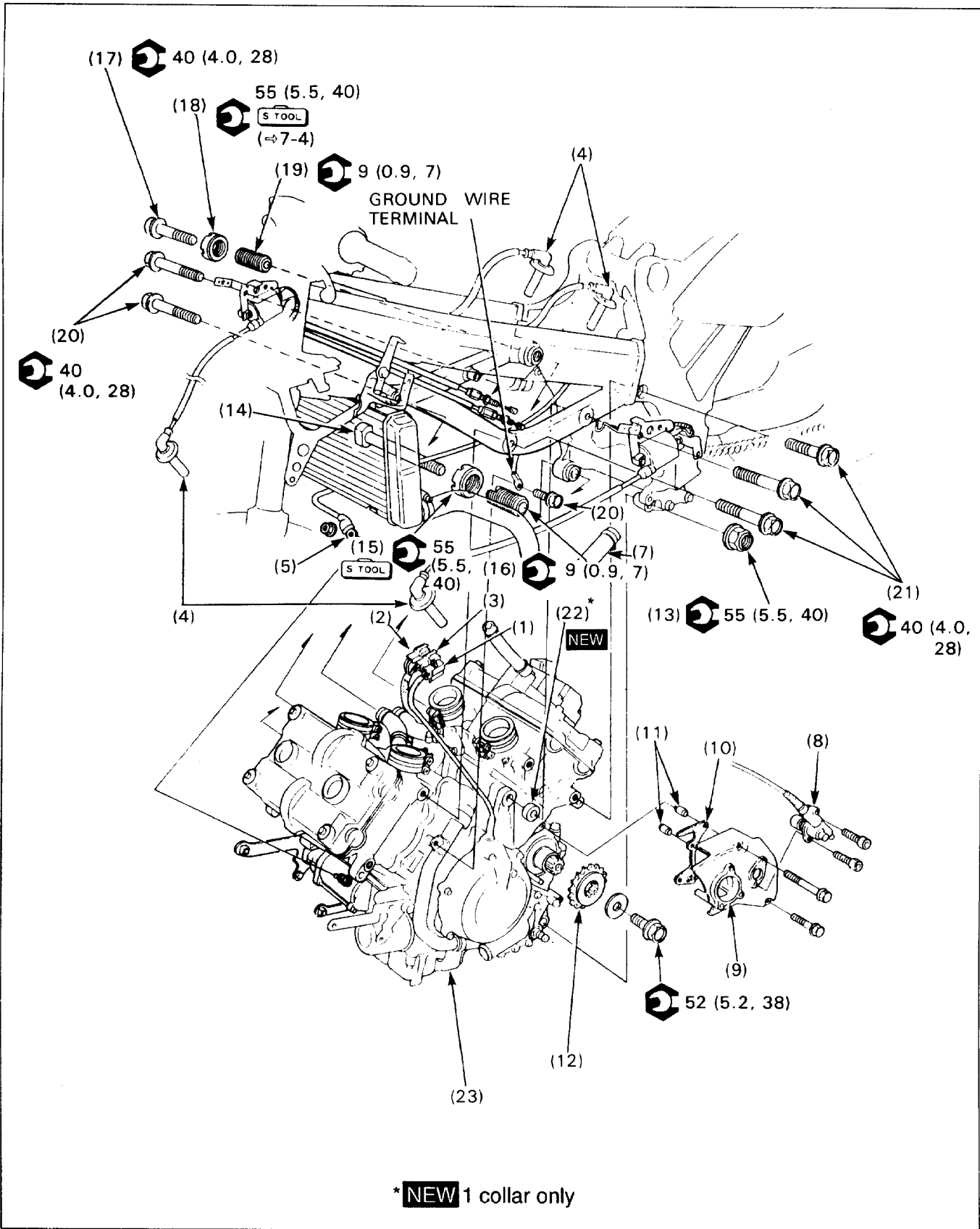

**CAUTION**

- Do not use the oil filter as a jack point.

**NOTE**

- Support the motorcycle using a hoist or a jack.
- Turn the ignition switch OFF and disconnect the battery (–) cable.
- When removing the engine, be careful not to pinch the wire harnesses between the engine and frame.
- If you plan to remove the clutch lock nut, primary drive gear bolt and/or flywheel bolt, loosen them in advance of engine removal for easy removal.

**Requisite Service**

- Lower center fairing removal/installation (page 2-8)
- Fuel tank removal/installation (page 2-22)
- Air cleaner housing removal/installation (page 6-3)
- Carburetor removal/installation (page 6-4)
- Thermostat removal/installation (page 5-4)
- Oil hose removal/installation (page 4-5)
- PAIR control valve removal/installation (page 6-25)
- Clutch slave cylinder removal/installation (page 9-8)
- Engine oil draining/refilling
- Remove the radiator lower mounting bolt and loosen the upper mounting bolt (page 5-5). Swing the radiator forward.
- Coolant draining/refilling (page 5-3 and section 5 of the Common Service Manual)

Procedure	Q'ty	Remarks
<b>Removal Order</b>		• Installation is in the reverse order of removal.
(1) AC generator connector	1	
(2) Oil pressure switch connector	1	
(3) Ignition pulse generator connector	1	
(4) Spark plug cap	4	
(5) Starter motor cable	1	
(6) Neutral switch wire	1	
(7) Water hose	1	After connecting, secure with the hose band.
(8) Speedometer cable	1	'90-'93
Speed sensor	1	After '93
(9) Drive sprocket cover	1	
(10) Gasket	1	
(11) Dowel pin	2	
(12) Drive sprocket	1	Loosen the drive chain fully (page 3-12) before removing the drive sprocket.
(13) Rear lower engine mounting nut	1	
(14) Rear lower engine mounting bolt	1	
(15) Adjusting bolt lock nut	1	Refer to page 7-4 for installation.
(16) Adjusting bolt	1	
(17) Rear upper engine mounting bolt	1	
(18) Adjusting bolt lock nut	1	Refer to page 7-4 for installation.
(19) Adjusting bolt	1	
(20) Water pipe mounting bolt	1	Tighten with the ground wire terminal.
(21) Engine mounting bolt	5	Tighten with the No. 2 and No. 4 ignition coil stay.
(22) Collar	1	<b>NEW</b>
(23) Engine assembly		

## Engine Mounting Bolt Installation

### Rear Lower Engine Mounting Bolt

Apply a thin coating of grease on the rear lower engine mounting bolt.

Tighten the adjusting bolt fully by hand, and insert the engine mounting bolt fitting the bolt head with the cut-out in the adjusting bolt.

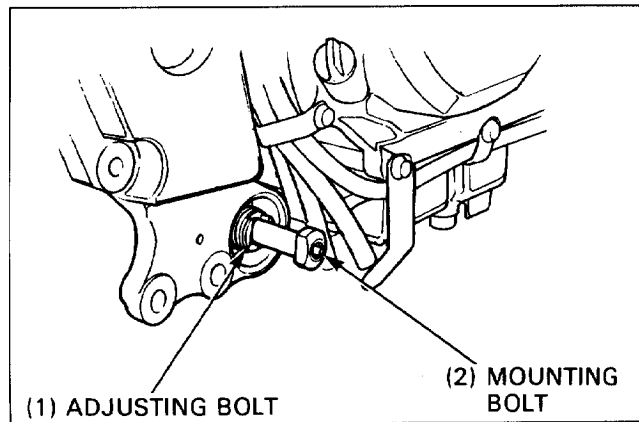

Tighten the adjusting bolt with the mounting bolt.

**Torque: 9N · m (0.9kg-m, 7ft-lb)**

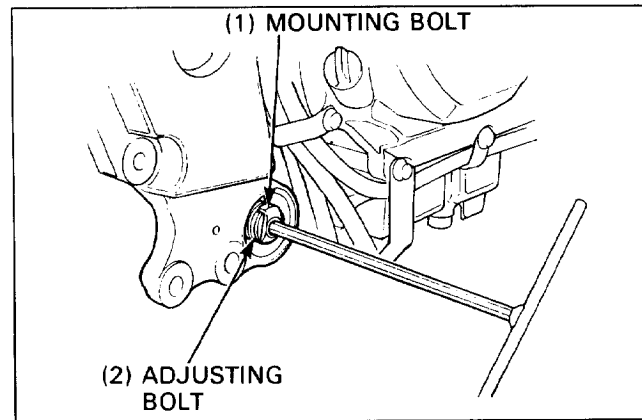

Tighten the lock nut holding the engine mounting bolt.

**Torque: 55N · m (5.5kg-m, 40ft-lb)**

**Lock nut wrench**

**07HMA-MR70200**

Tighten the rear lower engine mounting nut.

**Torque: 55N · m (5.5kg-m, 40ft-lb)**

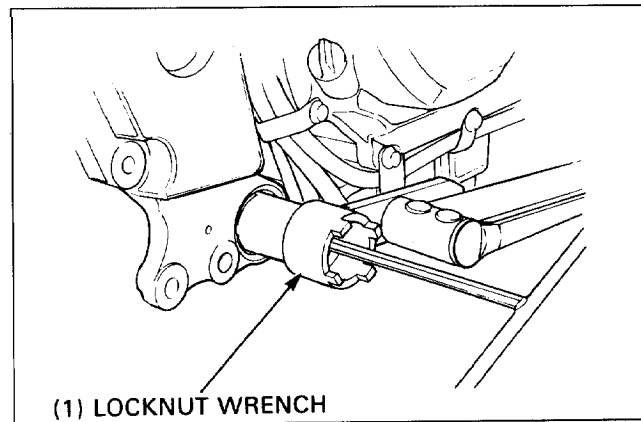

### Rear Upper Engine Mounting Bolt

#### NOTE

- Perform the rear upper engine mounting bolt tightening procedure after tightening the other engine mounting bolts.

Tighten the adjusting bolt to the specified torque.

**Torque: 9N · m (0.9kg-m, 7ft-lb)**

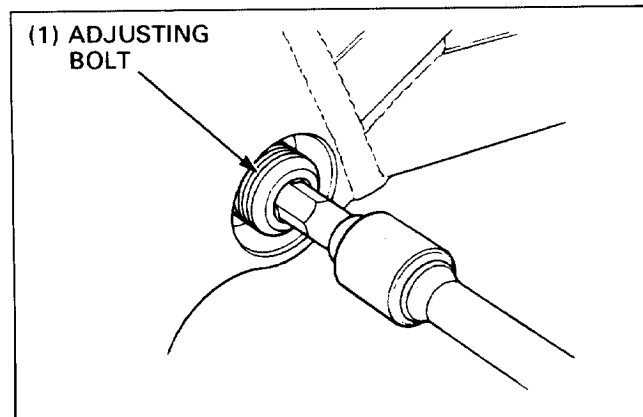

Tighten the lock nut holding the adjusting bolt.  
Torque: 55N · m (5.5kg-m, 40ft-lb)

Lock nut wrench

07HMA-MR70200

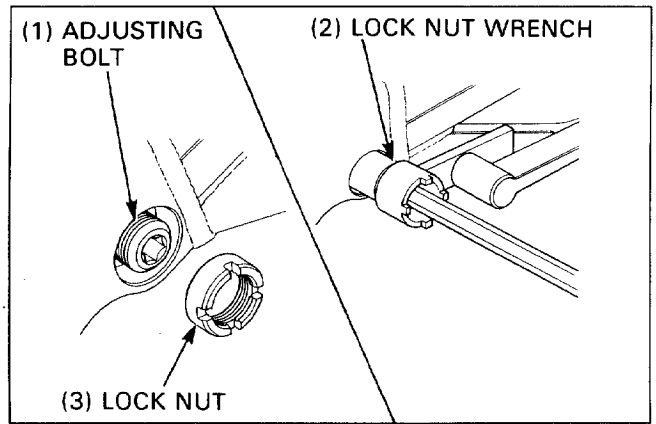

Install and tighten the rear lower engine mounting bolt.

Torque: 40N · m (4.0kg-m, 28ft-lb)

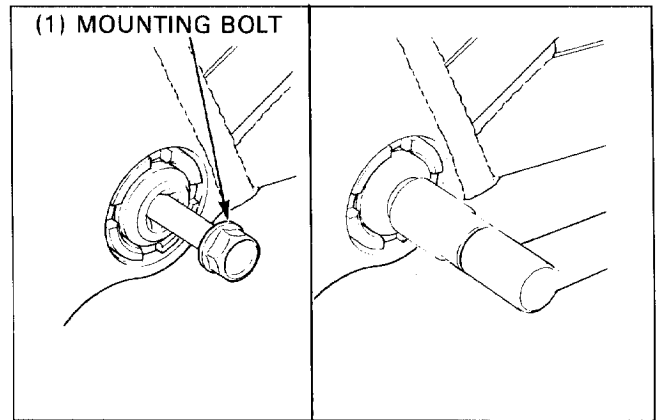



# 8. Cylinder Head/Valves

<b>Service Information</b>	<b>8-1</b>	<b>Cylinder Head, Camshaft Idle Gear</b>	
<b>Troubleshooting</b>	<b>8-1</b>	<b>Case Removal/Installation</b>	<b>8-4</b>
<b>Camshaft Removal</b>	<b>8-2</b>	<b>Cylinder Head Disassembly/Assembly</b>	<b>8-6</b>
		<b>Camshaft Installation</b>	<b>8-8</b>

## Service Information

- The front cylinder head can be removed with the engine in the frame.
- The rear cylinder head cannot be removed with the engine in the frame; however its camshafts and the cam drive gear case can be serviced with the engine in the frame.
- Camshaft lubricating oil is fed through oil passages in the cylinder head. Clean the oil passages before assembling the cylinder head. Fill the cylinder head oil pockets with the clean engine oil of the proper type and viscosity.
- Clean all disassembled parts with non-flammable or high flash point cleaning solvent and dry them by blowing them off with compressed air before inspection.
- Before reassembly, lubricate the camshaft journals and cam lobes with a molybdenum oil solution.
- When disassembling, mark and store the disassembled parts to ensure that they are reinstalled in their proper locations.
- The cylinder numbering is given below:
- The crankshaft rotates clockwise and the camshafts rotate counterclockwise when viewed from the right.

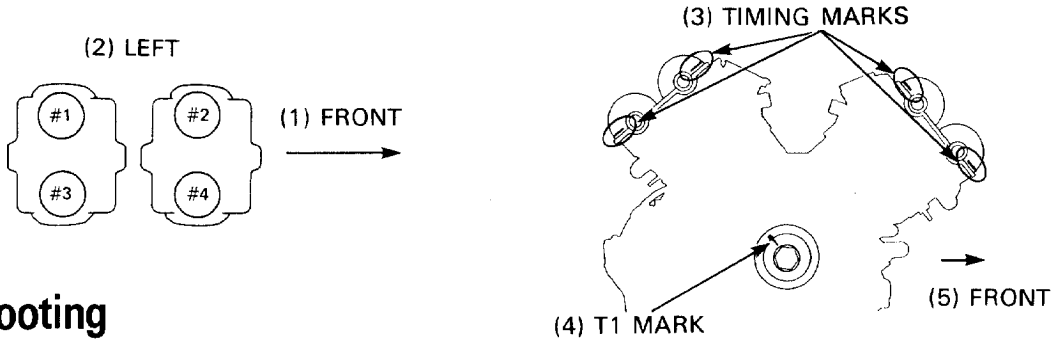

## Troubleshooting

Engine top-end problems usually affect engine performance. These can be diagnosed by a compression or leak-down test, or by tracing noises in the top-end with a sounding rod or stethoscope.

### NOTE

- For cylinder compression and leak-down test procedures, refer to section 3 of the Common Service Manual.

### Rough idle

- Low cylinder compression

### Low compression

- Incorrect valve shim adjustment (page 3-7)
- Burned or bent valves
- Incorrect valve timing
- Broken valve spring
- Uneven valve seating
- Leaking or damaged head gasket
- Warped or cracked cylinder head
- Loose spark plug
- Worn, stuck or broken piston rings
- Worn or damaged cylinder and piston

### Compression too high

- Excessive carbon build-up on piston top or combustion chamber

### Excessive smoke

- Worn valve stem or valve guide
- Damaged stem seal
- Worn cylinder, piston or piston rings
- Improper installation of piston rings
- Scored or scratched piston or cylinder wall

### Excessive noise

- Incorrect valve shim adjustment (page 3-7)
- Sticking valve or broken valve spring
- Damaged or worn camshaft
- Damaged camshaft drive gear

### Abnormal noise (piston)

- Worn cylinder and piston
- Worn piston pin or piston pin hole
- Worn connecting rod big end bearing

# Camshaft Removal

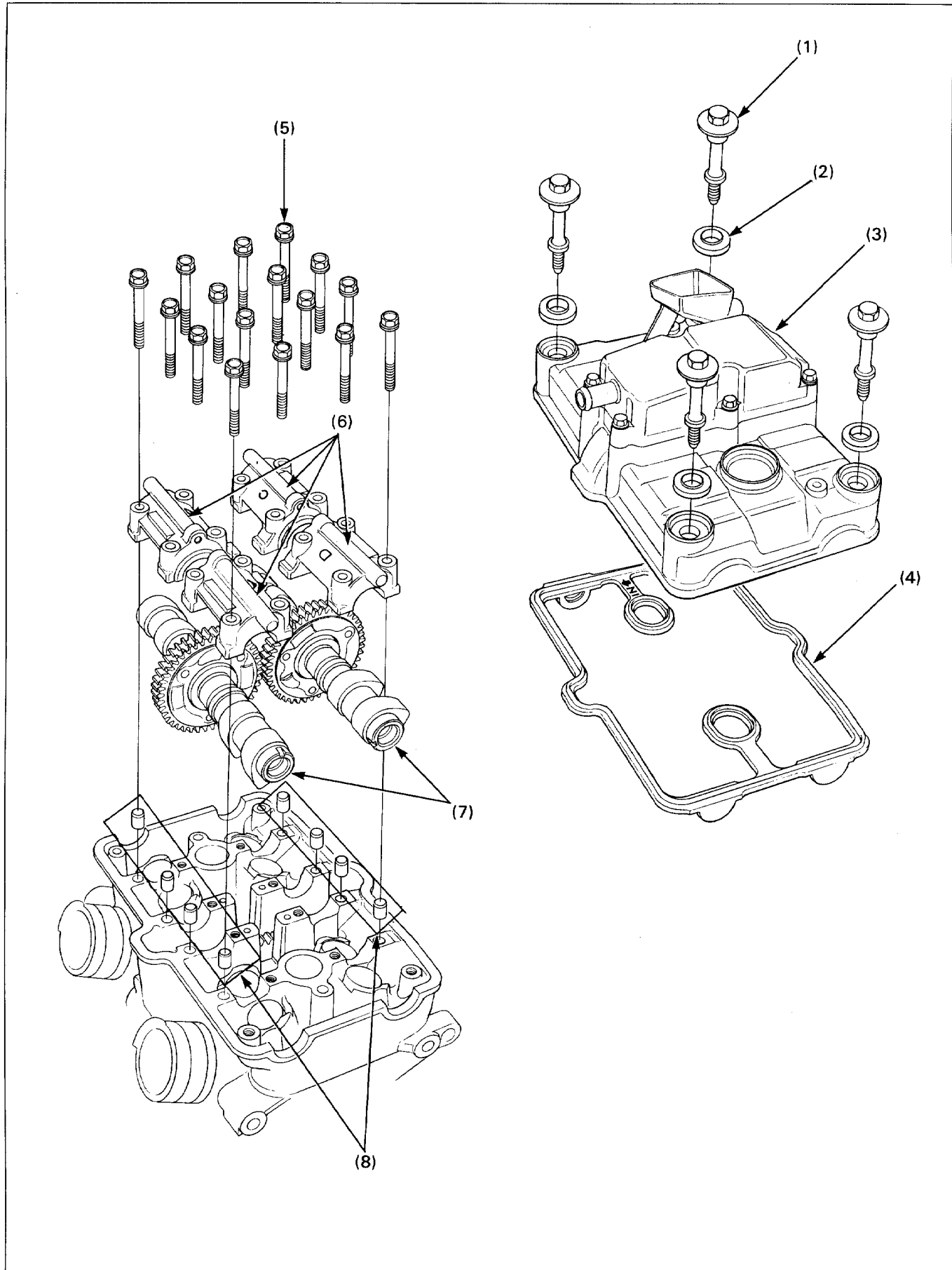

NOTE

- This service procedure is specific to for the rear cylinder head, but the front cylinder head service is the same.
- Keep the front and rear parts separate so as not to confuse them.
- Be careful not to let any parts fall in the engine opening.

**Requisite Service**

- Radiator removal (page 5-5)
- Carburetor removal (page 6-4)
- Thermostat housing removal (page 5-4)
- Water pipe removal (page 5-7)
- Spark plug removal

Procedure		Q'ty	Remarks
(1)	Cylinder head cover bolt	4	<p>NOTE:</p> <ul style="list-style-type: none"> <li>• Before loosening, align the "1T" (front cylinder: "2T") mark on the starter clutch with the index mark on the right crankcase cover, and make sure the No. 1 piston (front cylinder: No.2 piston) is on the compression stroke. Unless it is on the compression stroke, turn the crankshaft clockwise 360° and align the marks again.</li> <li>• Loosen the holder bolts in a gradual, crisscross pattern.</li> <li>• The holder bolts are different between the dowel pin side and the others in length. Keep separate for installation.</li> </ul>
(2)	Washer	4	
(3)	Cylinder head cover	1	
(4)	Cylinder head cover packing	1	
(5)	Camshaft holder bolt	16	
(6)	Camshaft holder	4	
(7)	Camshaft IN/EX	2	
(8)	Dowel pin	8	

# Cylinder Head, Camshaft Idle Gear Case Removal/Installation

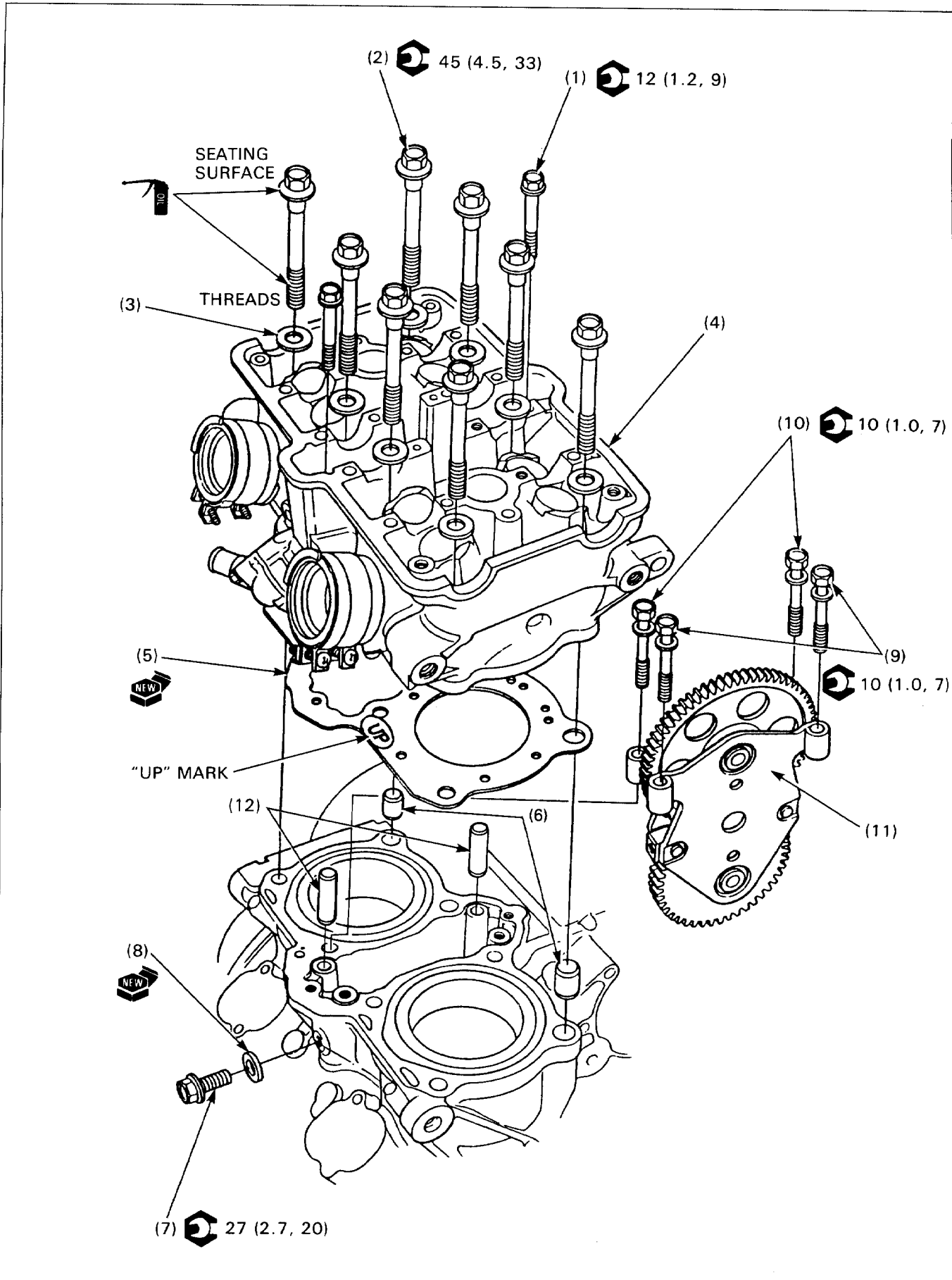

**CAUTION**

- Apply engine oil to the seat and threads of the cylinder head mounting bolts.

**NOTE**

- This service procedure is specific to the rear cylinder head, but the front cylinder head service is the same.
- Before removing the engine mounting bolts, support the engine with a floor jack or other support to avoid overloading the other bolts.

**Requisite Service**

FRONT CYLINDER: Radiator removal/installation (page 5-5), Thermostat housing removal/installation (page 5-4)  
Air injection pipe removal/installation (page 6-25)

FRONT AND REAR CYLINDER: Camshaft removal/installation (page 8-2), Coolant draining/refilling (page 5-3), Exhaust pipe removal/installation (page 2-14), Engine mounting bolt removal/installation (page 7-2), Air injection pipe removal/installation (page 6-25)

Procedure		Q'ty	Remarks
<b>Removal Order</b>			• Installation is in the reverse order of removal.
(1)	Cylinder head mounting bolt (6 mm)	2	Refer to page 8-10 for installation.
(2)	Cylinder head mounting bolt (9 mm)	8	
(3)	Washer	8	
(4)	Cylinder head assembly	1	Install with the "UP" mark facing up.
(5)	Gasket	1	
(6)	Dowel pin	2	Refer to page 8-10 for installation.
(7)	Camshaft idle gear case mounting bolt (8 mm)	1	
(8)	Sealing washer	1	
(9)	Camshaft idle gear case mounting bolt (6x40)	2	
(10)	Camshaft idle gear case mounting bolt (6x45)	2	
(11)	Camshaft idle gear case	1	
(12)	Dowel pin	2	

# Cylinder Head Disassembly/Assembly

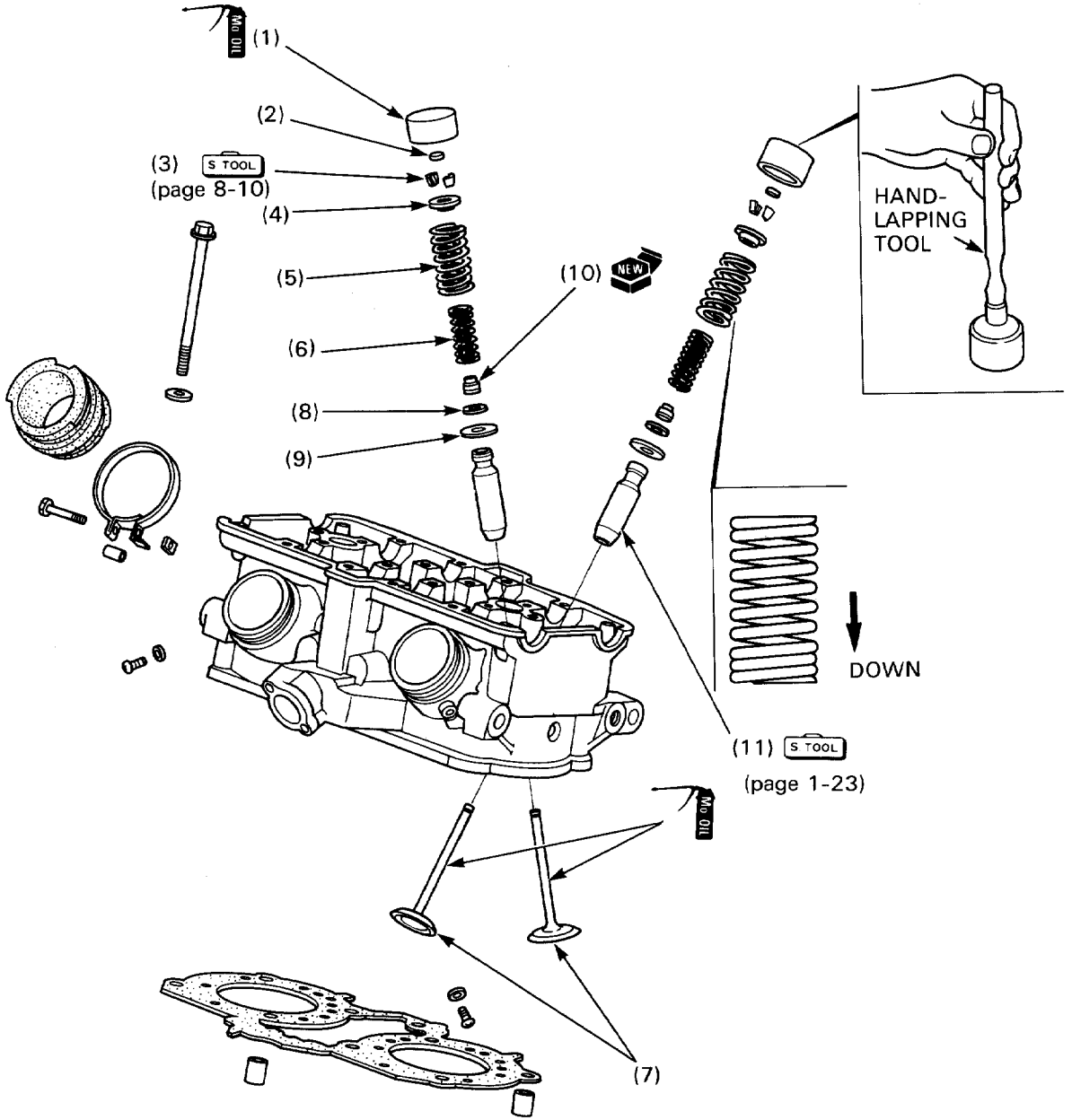

**CAUTION**

- Keep the valve components in the same order they were installed so they can be installed in the original positions.
- Do not compress the valve spring more than necessary.

**NOTE**

- Refer to section 9 of the Common Service Manual for valve guide inspection/replacement.

**Requisite Service**

- Cylinder head removal/installation (page 8-4)

	Procedure	Q'ty	Remarks
	<b>Disassembly Order</b>		
(1)	Valve bucket	8	• Assembly is in the reverse order of disassembly. NOTE: • Remove using a handlapping tool. Do not damage the cylinder head-bucket sliding surface.
(2)	Valve shim	8	
(3)	Valve cotter	16	Removal/installation (page 8-10)
(4)	Retainer	8	
(5)	Valve spring (outer)	8	Install them with the narrow pitch end facing down.
(6)	Valve spring (inner)	8	
(7)	Valve IN/EX	8	
(8)	Spring seat (inner)	8	
(9)	Spring seat (outer)	8	
(10)	Stem seal	8	
(11)	Valve guide	8	

# Camshaft Installation

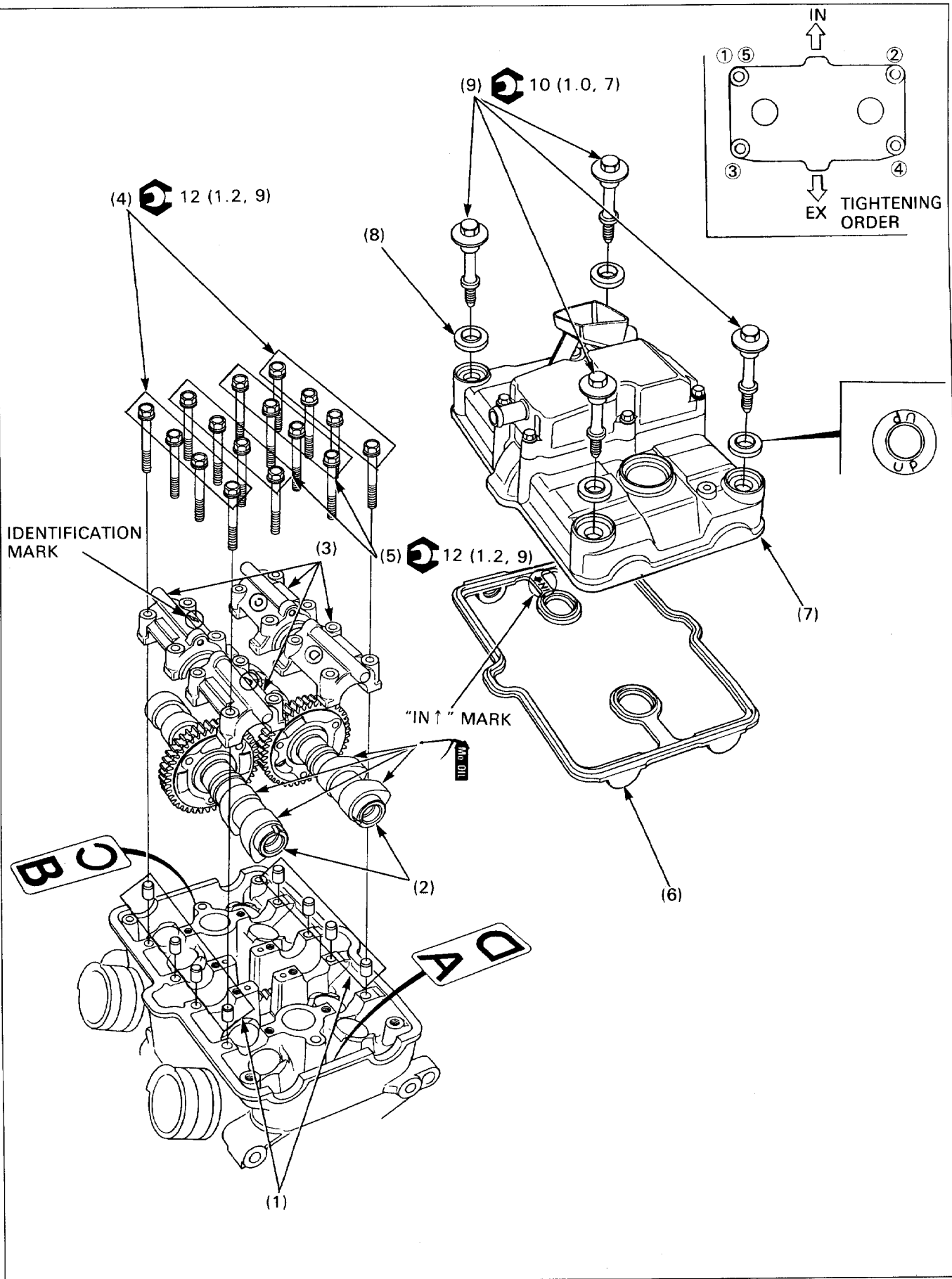

**NOTE**

- This service procedure is specific to the rear cylinder head, but the front cylinder head service is the same.
- Keep the front and rear parts separate so as not to confuse them.
- Each camshaft has an identification mark. Note these marks during installation to ensure that the camshafts are properly located:  

FRONT INTAKE: "FR", "IN"	REAR INTAKE: "RR", "IN"
FRONT EXHAUST: "FR", "EX"	REAR EXHAUST: "RR", "EX"
- Be careful not to let any parts fall in the engine opening.

**Requisite Service**

- |                                                                                                                                                                                 |                                                                                                                                    |
|---------------------------------------------------------------------------------------------------------------------------------------------------------------------------------|------------------------------------------------------------------------------------------------------------------------------------|
| <ul style="list-style-type: none"> <li>• Spark plug installation</li> <li>• Water pipe installation (page 5-7)</li> <li>• Thermostat housing installation (page 5-4)</li> </ul> | <ul style="list-style-type: none"> <li>• Carburetor installation (page 6-4)</li> <li>• Radiator installation (page 5-5)</li> </ul> |
|---------------------------------------------------------------------------------------------------------------------------------------------------------------------------------|------------------------------------------------------------------------------------------------------------------------------------|

	Procedure	Q'ty	Remarks
(1)	Dowel pin	8	Refer to page 8-11 for installation.  NOTE: • Apply Three bond 1521 or equivalent to the head cover and install the gasket with the "IN" mark facing the intake side.
(2)	Camshaft IN/EX	2	
(3)	Camshaft holder	4	
(4)	Camshaft holder bolt (6×45.5)	8	
(5)	Camshaft holder bolt (6×39.5)	8	
(6)	Cylinder head cover packing	1	
(7)	Cylinder head cover	1	Install with the "UP" mark facing up. Tighten the bolts in the order shown. Tighten the ① bolt again after tightening the other bolts.
(8)	Washer	4	
(9)	Cylinder head cover bolt	4	

## Valve Cotters Removal/Installation

Remove the valve buckets and shims.  
Install the valve bucket hole protector into the cylinder head-bucket sliding surface.

**S TOOL**

**Valve bucket hole protector**

**07HMG-MR70001**

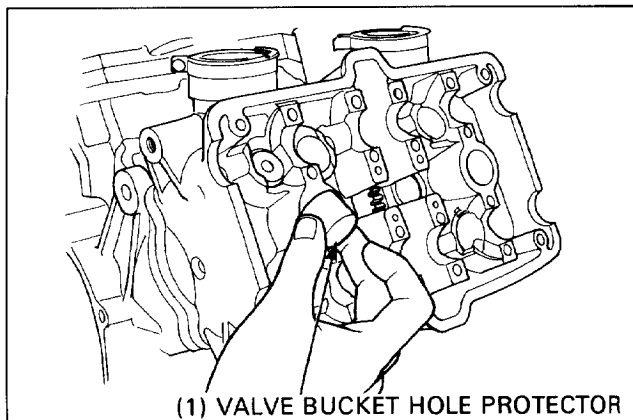

Install the valve spring compressor onto the valve and compress the valve spring.  
Remove (or install) the valve cotters.

**S TOOL**

**Valve spring compressor attachment**  
**Valve spring compressor**

**07959-KM30101**

**07757-0010000**

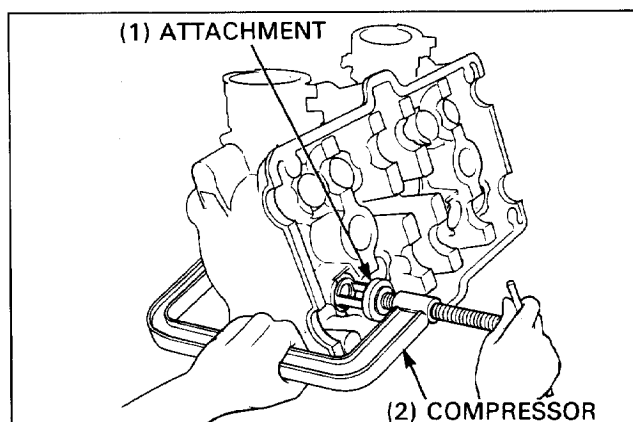

## Camshaft Idle Gear Case Installation

Install the camshaft idle gear case dowel pins until they are bottomed.

### NOTE

- If the dowel pins are not installed properly, the camshaft idle gear may not engage with the timing gear.
- The identification mark "F" (front) or "R" (rear) is stamped on each gear case. Install the gear cases in the correct cylinders.

Install the camshaft idle gear case onto the cylinder so that the idle gear engages with the timing gear on the crankshaft.

Install a new sealing washer and the mounting bolts.  
Tighten the bolts gradually in the order as shown.

### Torque:

6mm bolt: 10N·m (1.0kg-m, 7ft-lb)

8mm bolt: 23N·m (2.3kg-m, 17ft-lb)

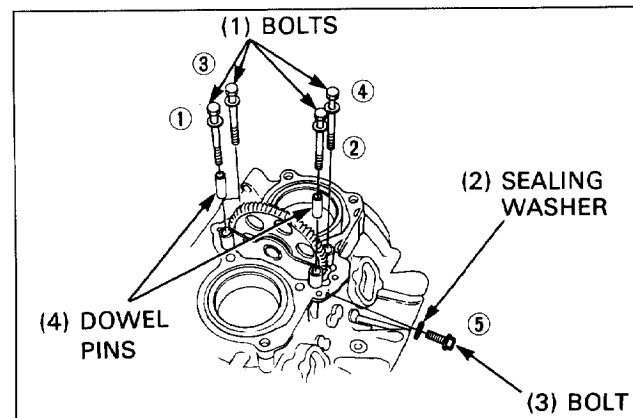
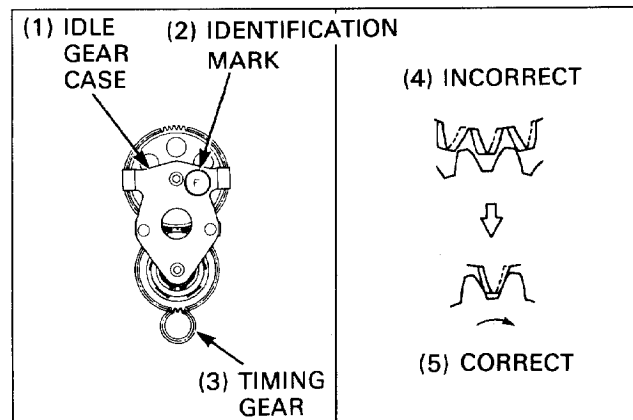

### Cylinder Head Bolt Installation

Apply engine oil to the seating surface and threads, then tighten the cylinder head mounting bolts gradually in a crisscross pattern in the order as shown:

**Torque:**

**6mm bolt: 12N · m (1.2kg-m, 9ft-lb)**

**9mm bolt: 45N · m (4.5kg-m, 33ft-lb)**

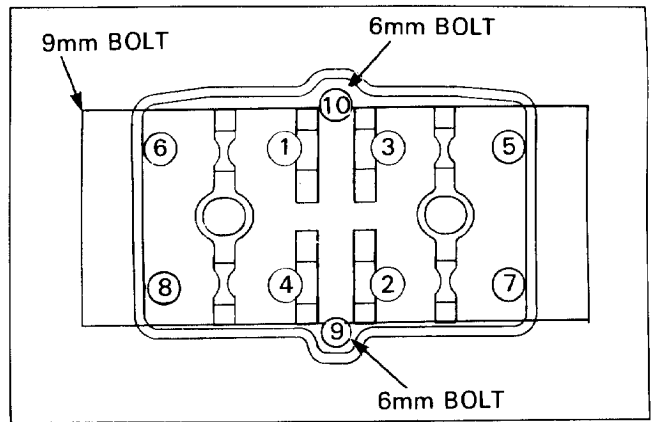

### Camshaft Installation

Each camshaft has identification marks. Install the camshafts in the correct positions, noting the identification marks below:

**Front Intake: "FR", "IN"**

**Front Exhaust: "FR", "EX"**

**Rear Intake: "RR", "IN"**

**Rear Exhaust: "RR", "EX"**

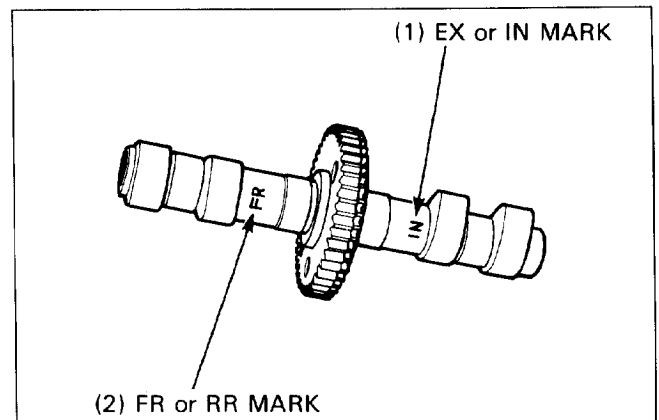

### When Both Front and Rear Cylinder Camshafts Were Removed

Align the T1 mark on the starter clutch with the index mark on the right crankcase cover.

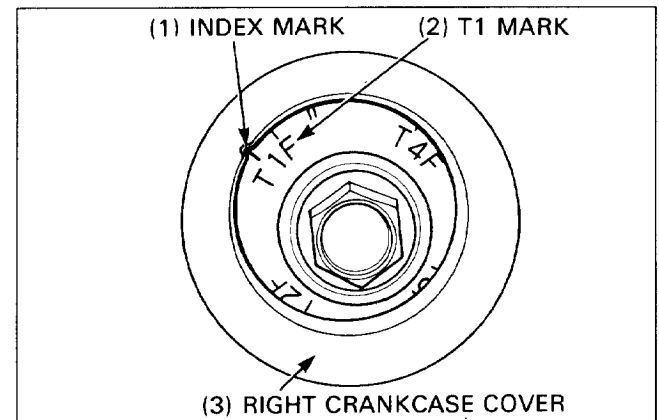

Apply molybdenum oil solution to the cam lobes. Install the camshafts onto the rear cylinder head so that the timing marks on the camshaft gears are level with the cylinder head upper edge and facing opposite each other.

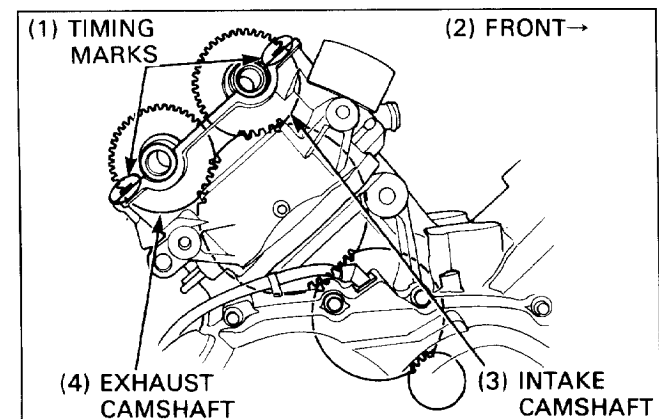

## Cylinder Head/Valves

Install the camshaft holder dowel pins onto the rear cylinder head.

Install the holders in the correct positions, checking the identification marks on the holders and the cylinder head. Tighten the holder bolts in the sequence as shown.

**Torque: 12 N · m (1.2kg-m, 7ft-lb)**

Make sure the timing marks on the camshaft gears are level with the cylinder head upper edge and facing opposite each other.

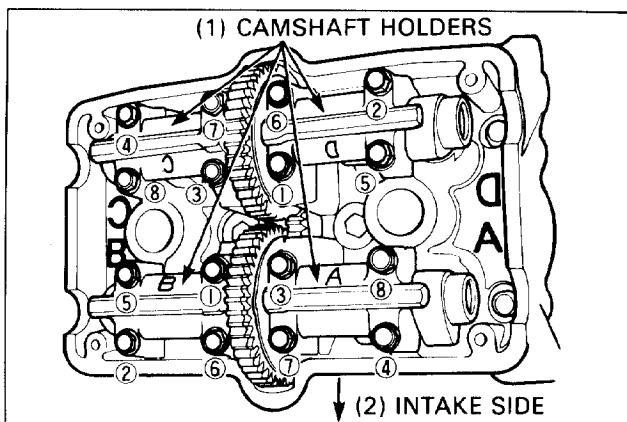

Align the T2 mark on the starter clutch with the index mark right crankcase cover by turning the crankshaft 1/4 turn (45°) clockwise.

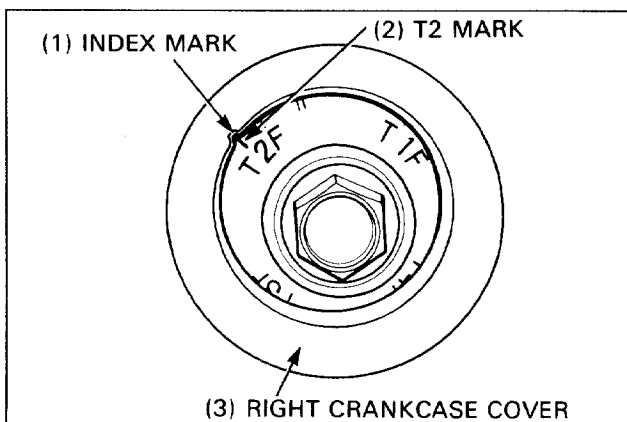

Apply molybdenum oil solution to the cam lobes.

Install the camshafts onto the front cylinder head so that the timing arrows on the camshaft gears face opposite each other as shown.

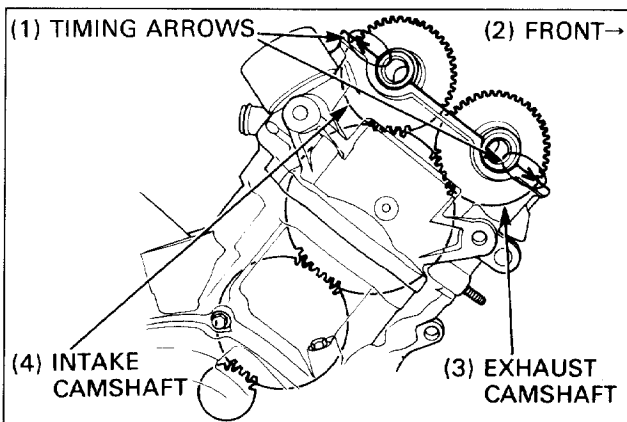

Install the camshaft holder dowel pins onto the front cylinder head.

Install the holders in the correct positions, checking the identification marks on the holders and the cylinder head. Tighten the holder bolts in the sequence as shown.

**Torque: 12N · m (1.2kg-m, 9ft-lb)**

Make sure the timing arrows on the camshaft gears are level with cylinder head upper edge and facing opposite each other.

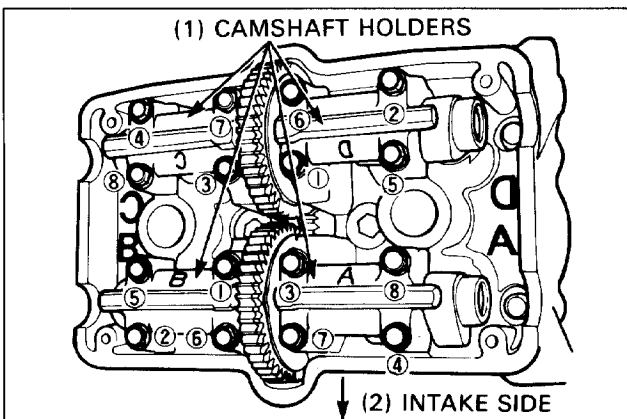

Valve timing will be correct when the timing arrows are level with the cylinder head upper edge, and the intake and exhaust timing arrows face opposite each other.

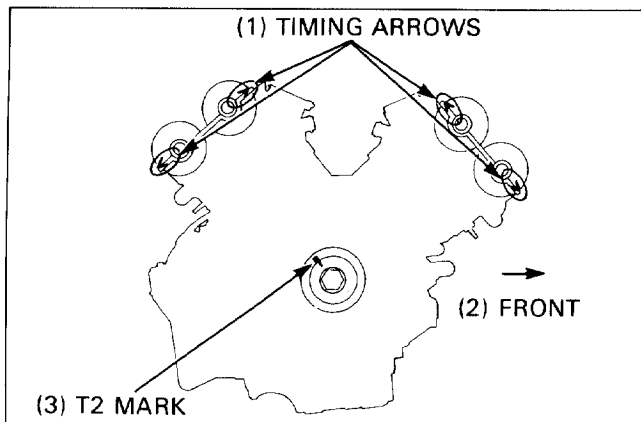

**When Only the Rear Cylinder Camshafts Were Removed**

Align the T2 mark with the index mark on the right crankcase cover.

Remove the front cylinder head cover.

Make sure #2 cylinder is at TDC on the compression stroke. If it is not, turn the crankshaft clockwise one full turn (360°) and make sure T2 mark aligns with the index mark on the right crankcase cover.

Rotate the crankshaft clockwise ¾ turn (270°) to align the T1 mark with the index mark on the right crankcase cover.

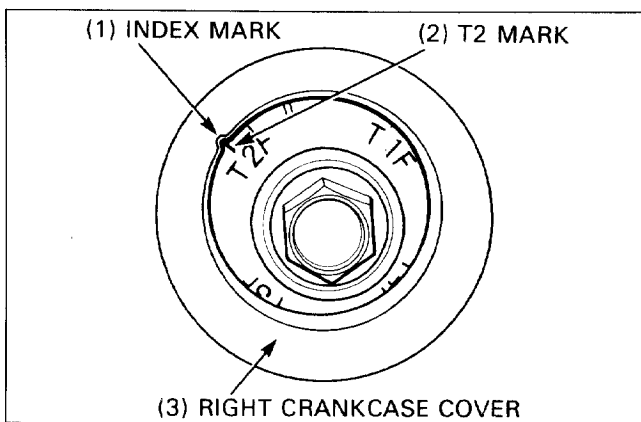

Apply molybdenum oil solution to the cam lobes.

Install the camshafts onto the rear cylinder head so that the timing marks on the camshaft gears are level with the cylinder head upper edge and facing opposite each other.

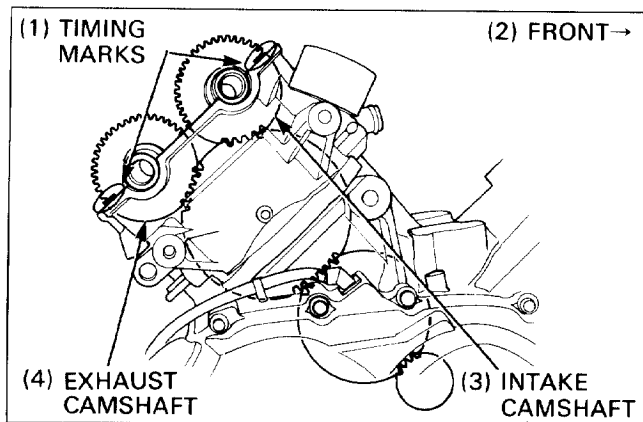

Install the camshaft holder dowel pins onto the rear cylinder head.

Install the holders in the correct positions, checking the identification marks on the holders and the cylinder head. Tighten the holder bolts in the sequence as shown.

**Torque: 12N · m (1.2kg-m, 9ft-lb)**

Make sure the timing marks on the camshaft gears are level with cylinder head upper edge and facing opposite each other.

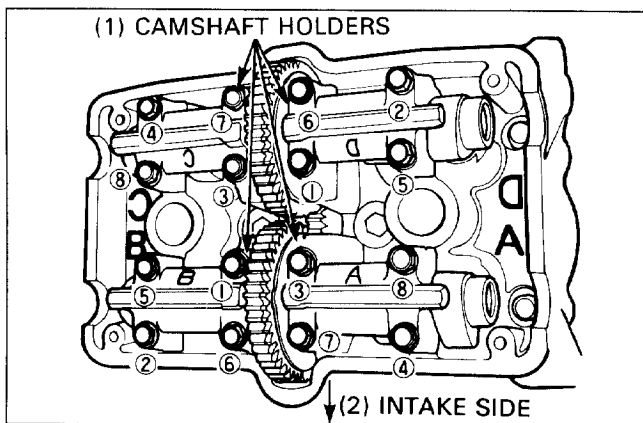

## Cylinder Head/Valves

Valve timing will be correct when the timing marks are level with the cylinder head upper edges, and the timing marks on the intake and exhaust camshaft face opposite each other.

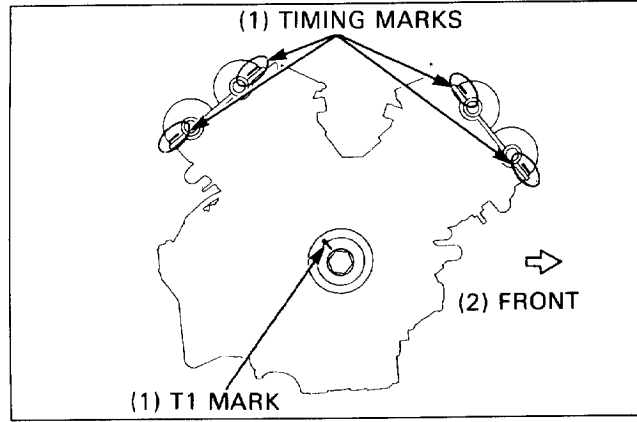

### When Only the Front Cylinder Camshafts Were Removed

Align the T1 mark with the index mark on the right crankcase cover.

Remove the rear cylinder head cover.

Make sure #1 cylinder is at TDC on the compression stroke. If it is not, turn the crankshaft clockwise one full turn (360°) and make sure T1 mark aligns with the index mark on the right crankcase cover.

Rotate the crankshaft clockwise 1¼ turns (450°) to align the T2 mark on the starter clutch with the index mark on the right crankcase cover.

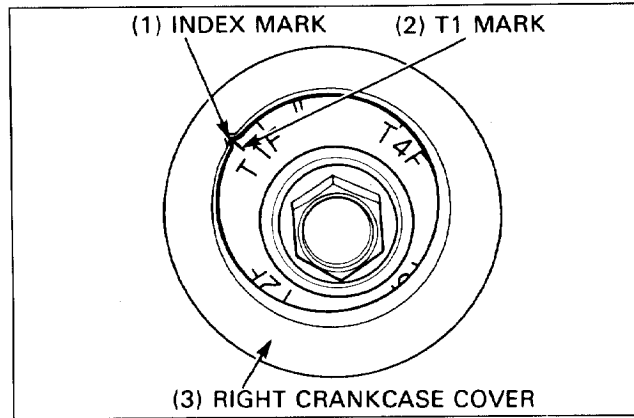

Apply molybdenum oil solution to the cam lobes.

Install the camshafts onto the front cylinder head so that the timing arrows on the camshaft gears face opposite each other as shown.

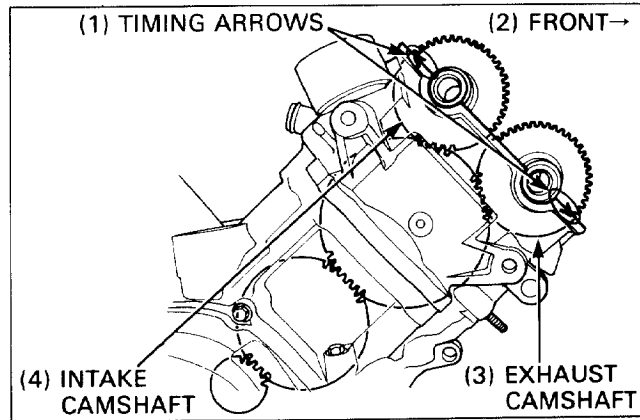

Install the camshaft holder dowel pins onto the rear cylinder head.

Install the holders in the correct positions, checking the identification marks on the holders and the cylinder head. Tighten the holder bolts in the sequence as shown.

**Torque: 12N · m(1.2kg·m, 9ft·lb)**

Make sure the timing arrows on the camshaft gears are level with cylinder head upper edge and facing opposite each other.

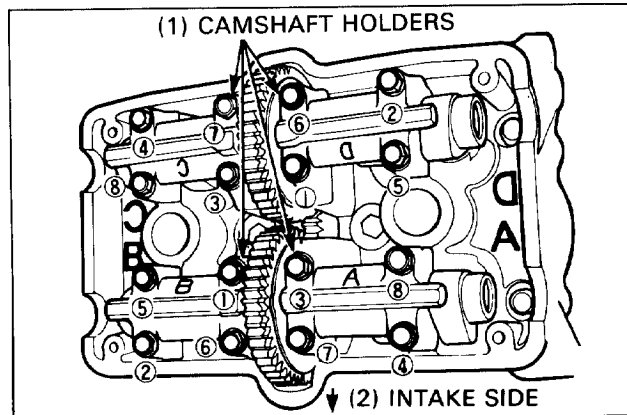

Valve timing is correct when the timing arrows are level with the cylinder head upper edges, and the intake and exhaust timing arrows face opposite each other.

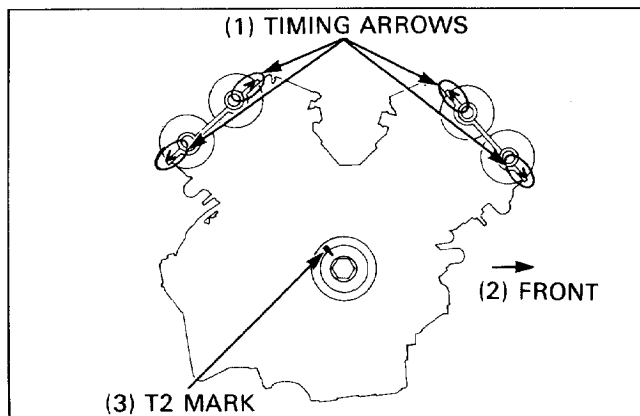



# 9. Clutch System

<b>Service Information</b>	<b>9-1</b>	<b>Clutch Installation</b>	<b>9-4</b>
<b>Troubleshooting</b>	<b>9-1</b>	<b>Clutch Master Cylinder Disassembly/ Assembly</b>	<b>9-7</b>
<b>Right Crankcase Cover Removal/ Installation</b>	<b>9-2</b>	<b>Clutch Slave Cylinder Disassembly/ Assembly</b>	<b>9-8</b>
<b>Clutch Removal</b>	<b>9-3</b>		

## Service Information

- Clutch and gearshift linkage maintenance can be done with the engine in the frame.
- Engine oil viscosity and level have an effect on clutch operation. When the clutch does not disengage or the vehicle creeps with clutch disengaged, inspect the engine oil and oil level before servicing the clutch system.
- Clean any gasket material off the crankcase cover-crankcase mating surface.
- Do not damage the cover-case mating surface.
- Never allow foreign materials to get into the engine.
- This section covers removal and installation of the clutch hydraulic system and mechanical clutch.
- DOT 4 brake fluid is used for the hydraulic clutch and is referred to as clutch fluid in the section. Do not use other types of fluid.
- Brake fluid will damage painted, plastic, and rubber parts. Whenever handling brake fluid, protect the painted, plastic, and rubber parts by covering them with a rag. If fluid does get on these parts, wipe it off with a clean cloth.

9

## Troubleshooting

### Clutch lever soft or spongy

- Air bubbles in hydraulic system
- Low fluid level
- Hydraulic system leaking

### Clutch lever too hard

- Sticking piston(s)
- Clogged hydraulic system

### Clutch slips

- Discs worn
- Springs weak
- Hydraulic system sticking

### Clutch will not disengage

- Air bubbles in hydraulic system
- Low fluid level
- Hydraulic system leaking
- Plates warped

### Motorcycle creeps with clutch disengaged

- Air bubbles in hydraulic system
- Low fluid level
- Hydraulic system leaking
- Plates warped

### Excessive lever pressure

- Lifter mechanism damaged
  - Lifter plate bearing damaged
  - Clutch push rod bent

### Clutch operation feels rough

- Outer drum slots rough
- Sticking piston(s)

# Right Crankcase Cover Removal/Installation

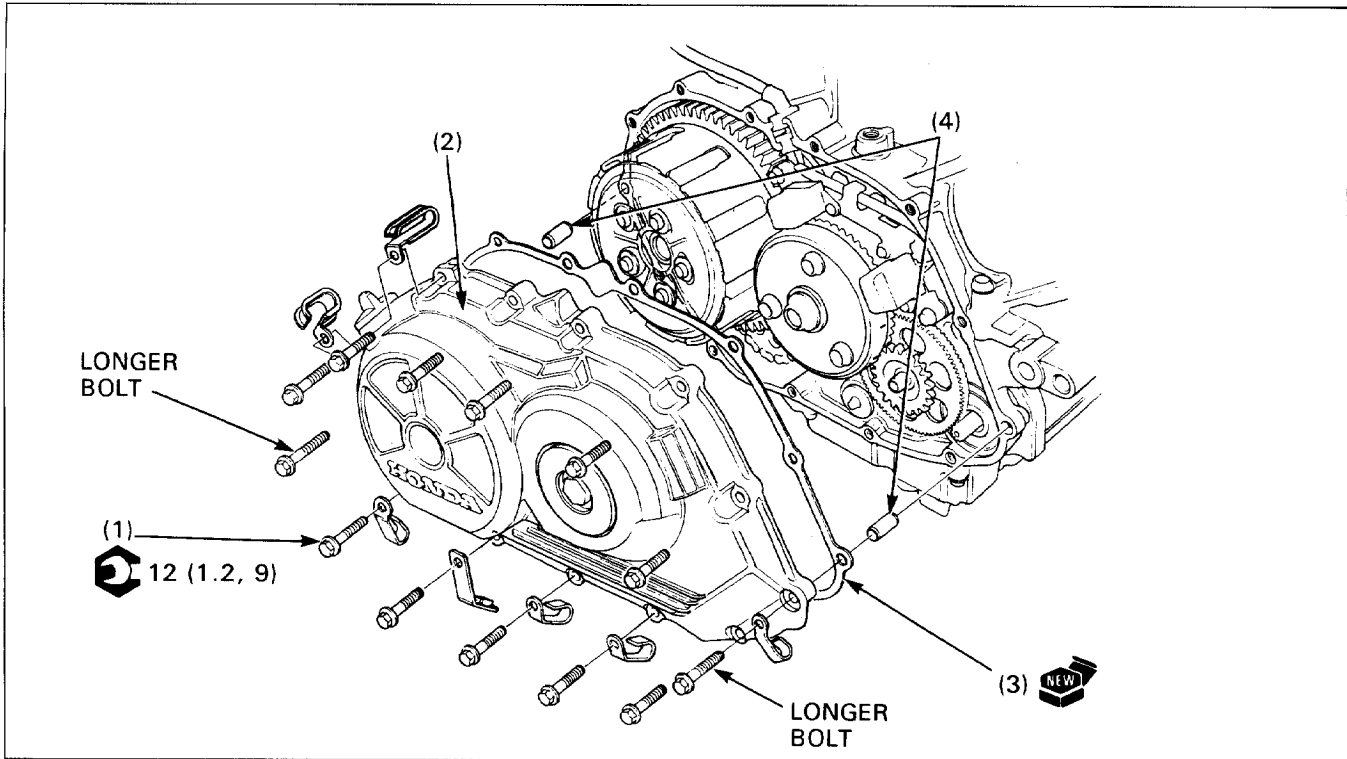

## Requisite Service

- Engine oil draining (drain bolt location: page 3-2, see: section 2 of the Common Service Manual)
- Lower fairing removal/installation (page 2-7)

	Procedure	Q'ty	Remarks
	<b>Removal Order</b>		
(1)	Right crankcase cover bolt	13	• Installation is in the reverse order of removal. <b>NOTE:</b> • Install the two longer bolts in the bolt holes with the dowel pins. • Install the clamps in the positions shown.
(2)	Right crankcase cover	1	
(3)	Gasket	1	
(4)	Dowel pin	2	

## Clutch Removal

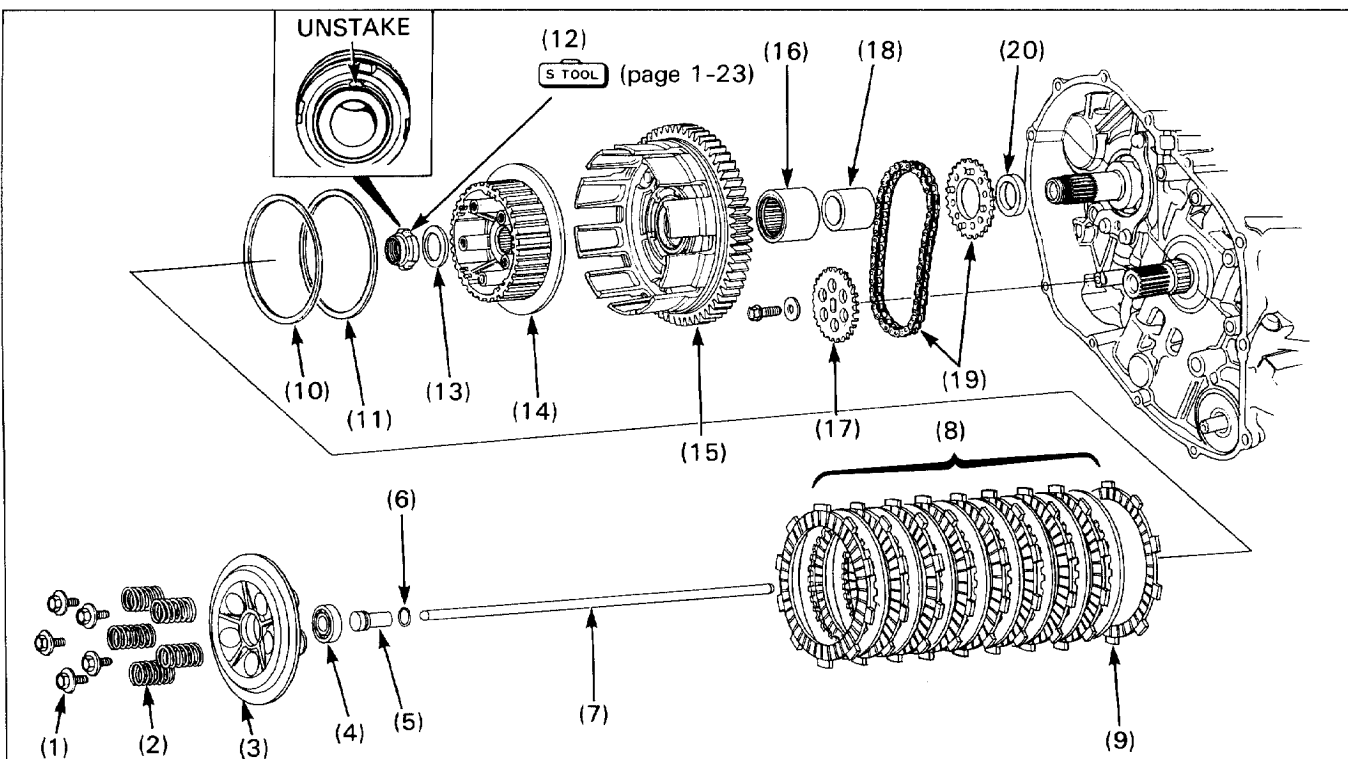

## Requisite Service

- Right crankcase cover removal (page 9-2)

- Starter clutch removal (page 17-10)

## NOTE

- When removing the oil pump driven sprocket, loosen the sprocket bolt before removing the clutch assembly. The bolt is treated with a locking agent so be careful not to damage the bolt when loosening.

Procedure	Q'ty	Remarks
(1) Clutch lifter plate bolt		Remove them in a gradual, crisscross pattern.
(2) Clutch spring	5	
(3) Clutch pressure plate	1	
(4) Clutch lifter plate bearing	1	
(5) Clutch lifter guide	1	
(6) Stopper ring	1	Detach from the lifter plate bearing only when replacing the bearing.
(7) Lifter rod	1	
(8) Clutch disc A/clutch plate	8/8	Larger I.D. than clutch disc A
(9) Clutch disc B	1	
(10) Judder spring	1	Refer to page 9-6 for removal.
(11) Spring seat	1	
(12) Clutch center lock nut	1	
(13) Spring washer	1	
(14) Clutch center	1	
(15) Clutch outer	1	
(16) Needle bearing	1	
(17) Oil pump driven sprocket	1	
(18) Clutch outer guide	1	
(19) Oil pump drive sprocket/drive chain	1/1	
(20) Collar	1	

# Clutch Installation

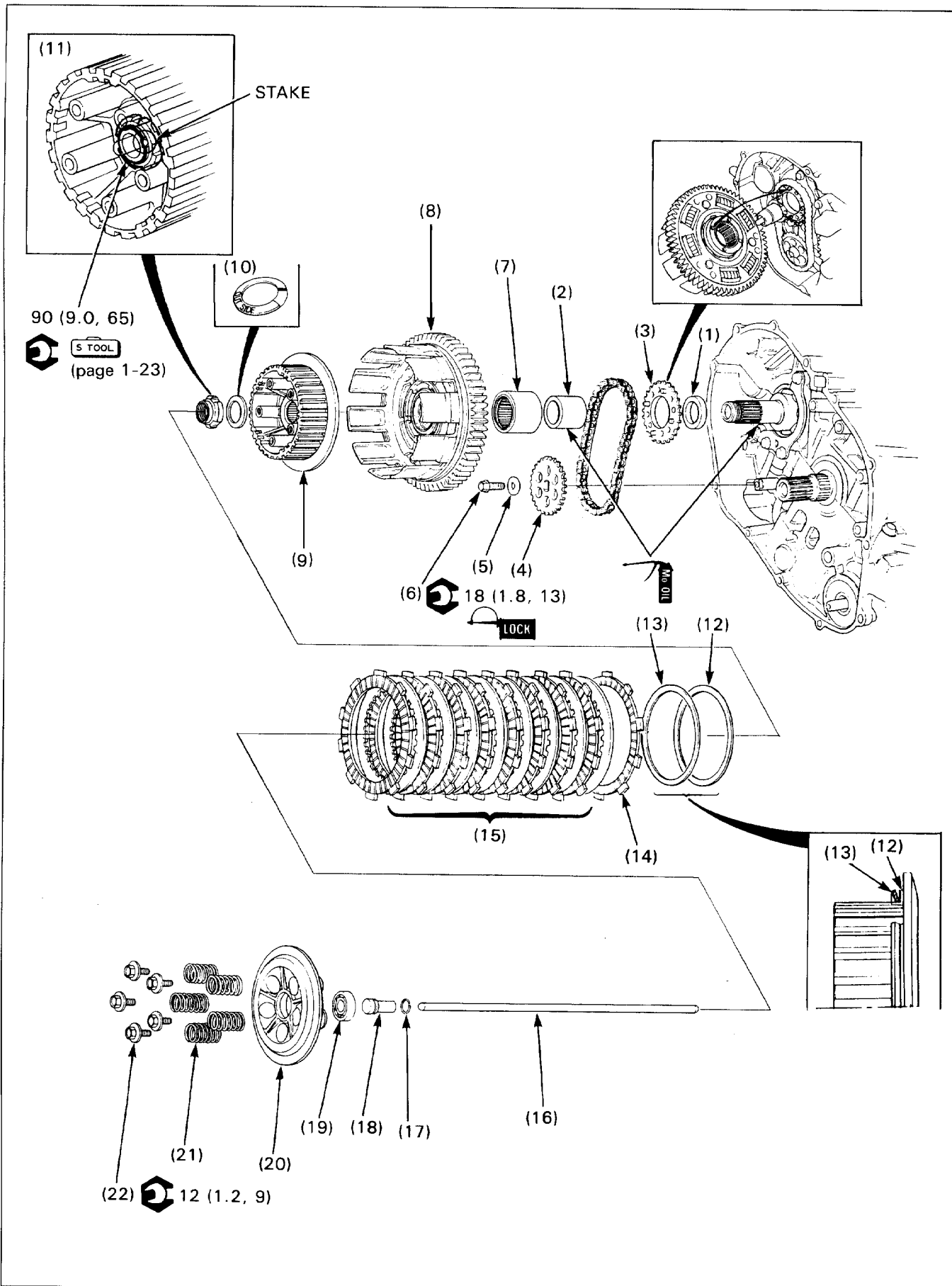

## Requisite Service

• Starter clutch installation (page 17-10)

• Right crankcase cover installation (page 9-2)

Procedure		Q'ty	Remarks
(1)	Collar	1	
(2)	Clutch outer guide	1	<b>CAUTION:</b> • Lubricate the inner and outer sliding surfaces with a molybdenum oil solution.
(3)	Oil pump drive sprocket/drive chain	1/1	Install the drive sprocket with the boss side facing out.
(4)	Oil pump driven sprocket	1	Install with the "IN" mark facing in, aligning the center hole with the oil pump shaft.
(5)	Washer	1	
(6)	Oil pump driven sprocket bolt	1	Apply a locking agent to the threads.
(7)	Needle bearing	1	
(8)	Clutch outer	1	<b>NOTE:</b> While holding the clutch outer and pushing in on it lightly, rotate the oil pump driven sprocket bolt clockwise. Install the clutch outer properly, aligning the clutch outer holes with the oil pump drive sprocket bosses.
(9)	Clutch center	1	
(10)	Spring washer	1	Install the "OUT SIDE" mark facing out.
(11)	Clutch center lock nut	1	Refer to page 9-6 for installation.
(12)	Spring seat	1	
(13)	Judder spring	1	Install the judder spring as shown.
(14)	Clutch disc B	1	Larger I.D. than clutch disc A.
(15)	Clutch disc A/clutch plate	8/8	
(16)	Lifter rod	1	
(17)	Stopper ring	1	Install securely into the lifter guide groove.
(18)	Clutch lifter guide	1	Install into the lifter plate bearing.
(19)	Clutch lifter plate bearing	1	Install into the lifter plate.
(20)	Clutch lifter plate	1	
(21)	Clutch spring	5	
(22)	Clutch lifter plate bolt	5	Tighten them in a gradual, crisscross pattern.

## Clutch System

### Clutch Center Lock Nut Removal

Unstake the lock nut, and loosen the lock nut while holding the clutch center as shown.

Clutch center holder  
Lock nut wrench, 26×30mm

07724-0050001  
07716-0020203

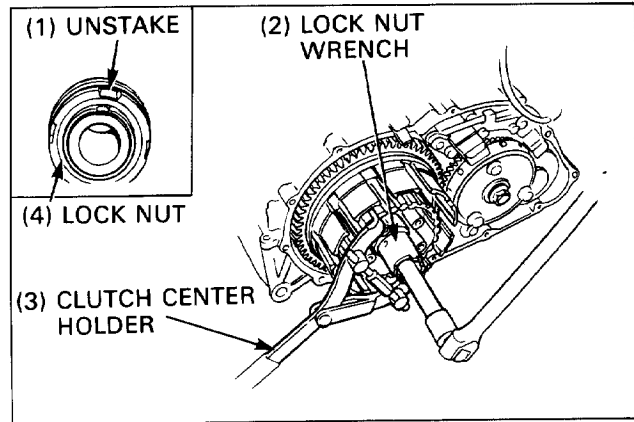

### Clutch Center Lock Nut Installation

Tighten the clutch center lock nut holding the clutch center as shown.

Clutch center holder  
Lock nut wrench, 26×30mm

07724-0050001  
07716-0020203

Stake the lock nut to the mainshaft.

#### NOTE

- Replace the lock nut if the old staked area of the nut aligns with the groove of the shaft after tightening the nut to specified torque.
- Be careful not to damage the shaft when staking the lock nut.
- Make sure that the peen point covers at least 2/3 of the width of the mainshaft groove.

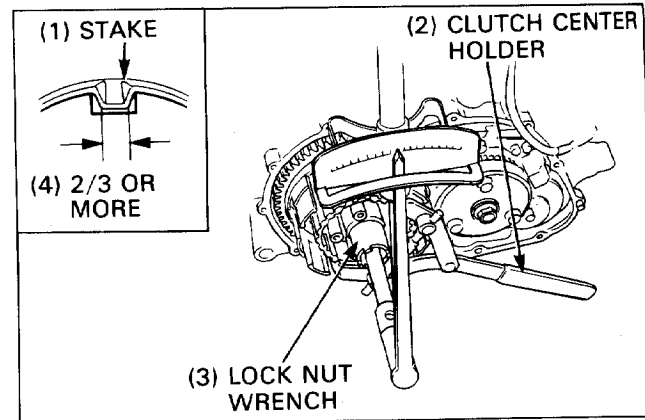

## Clutch Master Cylinder Disassembly/Assembly

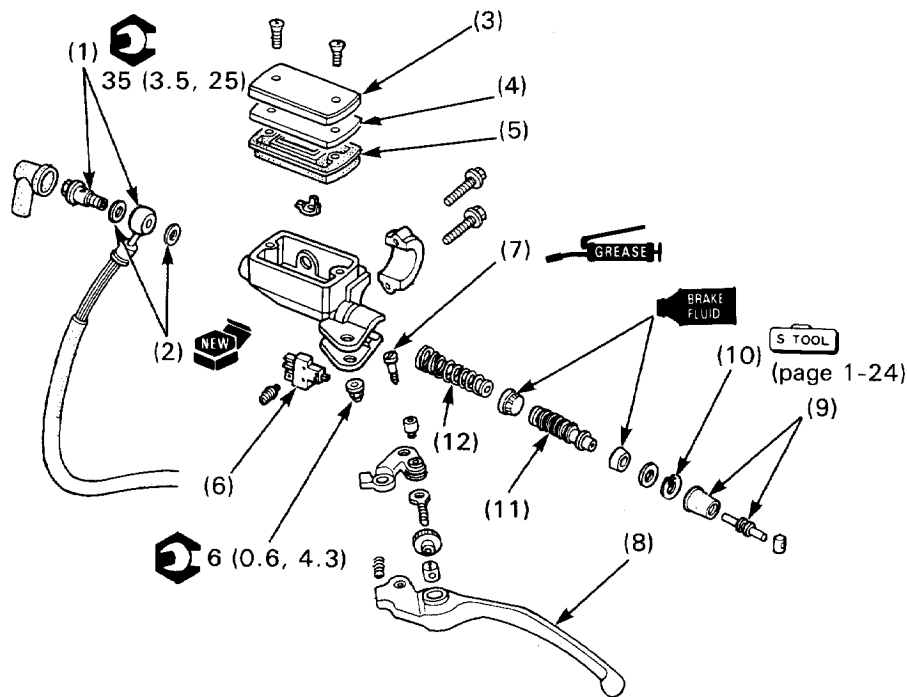

## NOTE

- Replace the master piston, spring, cups, stopper plate, snap ring and boot as a set.
- The master cylinder piston, cups and spring must be installed as a set.

## Requisite Service

- Clutch fluid replacement/air bleeding (page 11-27, 28 of the Common Service manual)
- Clutch master cylinder removal/installation (page 12-3)

Procedure	Q'ty	Remarks
<b>Disassembly Order</b>		
(1) Clutch fluid hose bolt/clutch fluid hose	1	<ul style="list-style-type: none"> <li>• Assembly is in the reverse order of disassembly. Refer to page 1-29 for correct routing.</li> </ul>
(2) Sealing washer	2	
(3) Reservoir cover	1	
(4) Diaphragm plate	1	
(5) Diaphragm	1	
(6) Clutch switch	1	
(7) Clutch lever pivot bolt	1	
(8) Clutch lever assembly	1	
(9) Push rod/boot	1/1	
(10) Snap ring		
(11) Master piston assembly	1	<b>NOTE:</b> <ul style="list-style-type: none"> <li>• Install the snap ring with the chamfered side facing inside.</li> <li>• Make sure the snap ring is fully seated in the groove.</li> </ul>
(12) Spring	1	Install with its tapered end toward the piston.

## Clutch Slave Cylinder Disassembly/Assembly

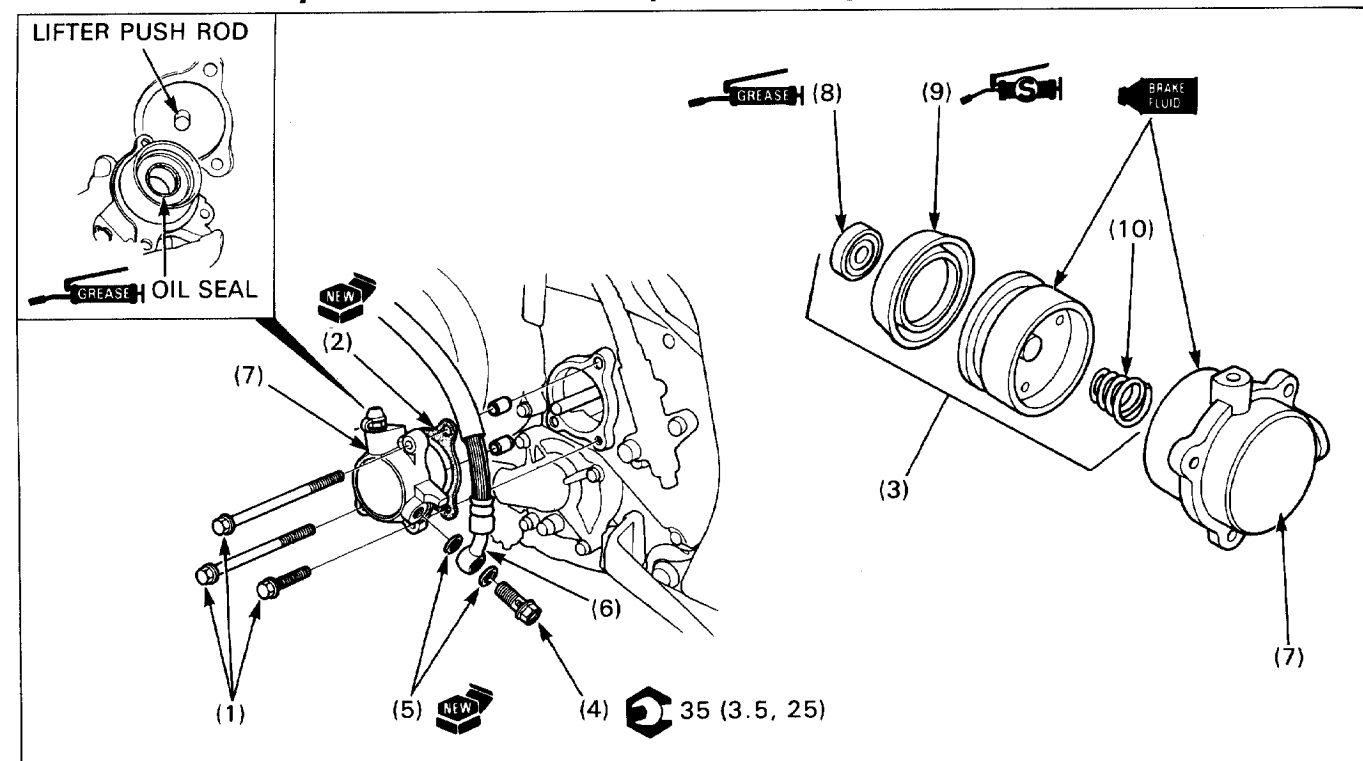

## Requisite Service

- Clutch fluid replacement/air bleeding (page 11-27, 28 of the Common Service Manual)

Procedure		Q'ty	Remarks
(1)	<b>Disassembly Order</b> Clutch slave cylinder mounting bolt	3	<ul style="list-style-type: none"> <li>• Assembly is in the reverse order of removal.</li> </ul> <b>NOTE:</b> <ul style="list-style-type: none"> <li>• Do not disconnect the clutch fluid hose until the piston has been removed.</li> </ul> <ul style="list-style-type: none"> <li>• Place a clean pan under the slave cylinder to catch the draining fluid and squeeze the clutch lever slowly to push out the piston.</li> </ul> Drain the clutch fluid. Temporarily install the slave cylinder then disconnect the clutch fluid hose. <ul style="list-style-type: none"> <li>• When installing, make sure that the clutch lifter push rod is installed properly.</li> </ul>
(2)	Gasket	1	
(3)	Clutch slave piston assembly	1	
(4)	Clutch fluid hose bolt	1	
(5)	Sealing washer	2	
(6)	Clutch fluid hose	1	
(7)	Clutch slave cylinder	1	
(8)	Oil seal	1	
(9)	Piston seal	1	
(10)	Spring	1	
			<b>NOTE:</b> <ul style="list-style-type: none"> <li>• Fit the piston seal securely into the slave cylinder groove.</li> </ul>

# 10. Gearshift Linkage

<b>Service Information</b>	<b>10-1</b>	<b>Drive Sprocket Cover Removal/ Installation</b>	<b>10-2</b>
<b>Troubleshooting</b>	<b>10-1</b>	<b>Gearshift Linkage Removal/ Installation</b>	<b>10-4</b>

## Service Information

- The gearshift linkage can be serviced with the engine in the frame.
- Do not damage the cover-case mating surface.
- Never allow foreign materials to get into the engine.

## Troubleshooting

### Hard to shift

- Misadjusted clutch cable
- Damaged or bent shift fork
- Bent shift fork shaft
- Worn gear dogs
- Incorrect engine oil viscosity
- Incorrect shifter plate assembly installation

### Jumps out of gear

- Damaged or bent shift fork
- Bent shift fork shaft
- Damaged stopper arm
- Worn gear engagement dogs or slots
- Damaged shift drum cam grooves

# Drive Sprocket Cover Removal/Installation

'90-'93:

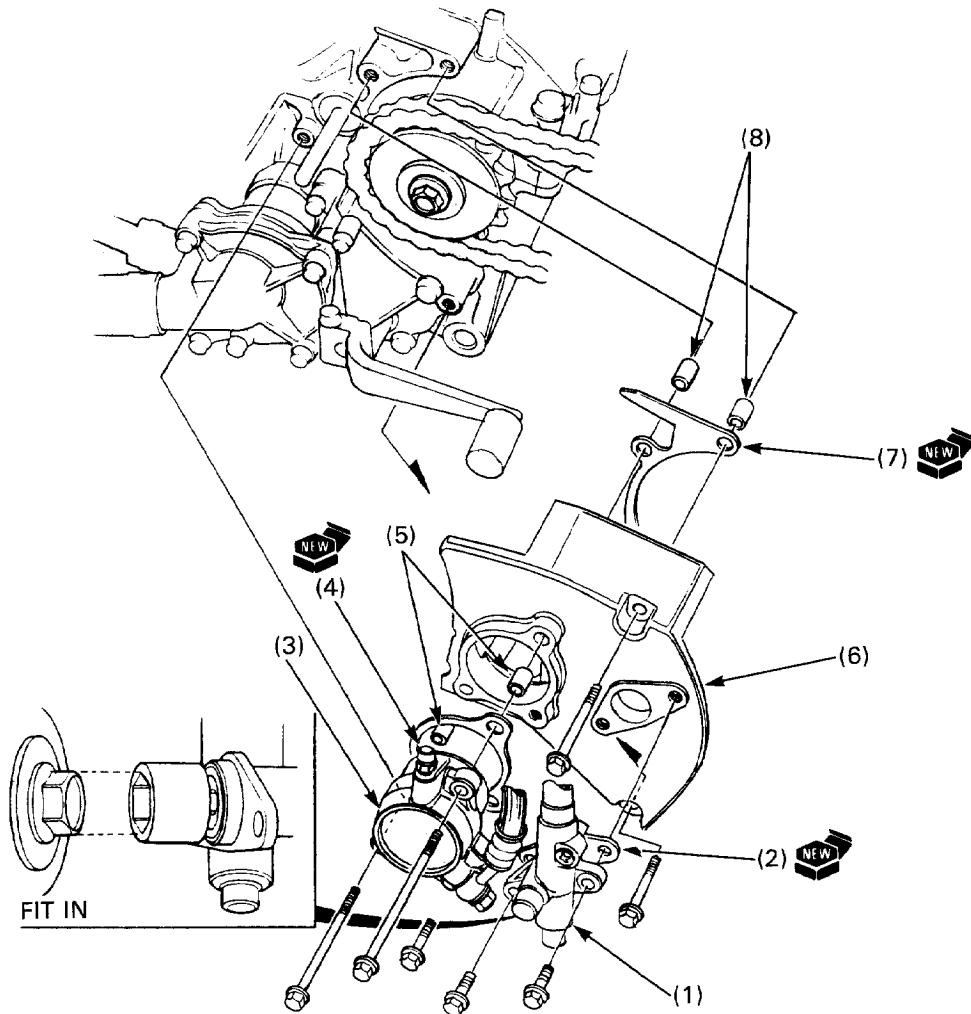

## Requisite Service

- Lower fairing removal/installation (page 2-7)

Procedure		Q'ty	Remarks
(1)	<b>Removal Order</b> Speedometer cable	1	• Installation is in the reverse order of removal. When installing, fit the hexagonal joint on the drive sprocket bolt head.
(2)	Gasket	1	
(3)	Clutch slave cylinder	1	<b>NOTE:</b> • Do not operate the clutch lever while slave cylinder is removed. The slave piston will be pushed out and installation will be difficult.
(4)	Gasket	1	
(5)	Dowel pin	2	
(6)	Drive sprocket cover	1	
(7)	Gasket	1	
(8)	Dowel pin	2	

After '93:

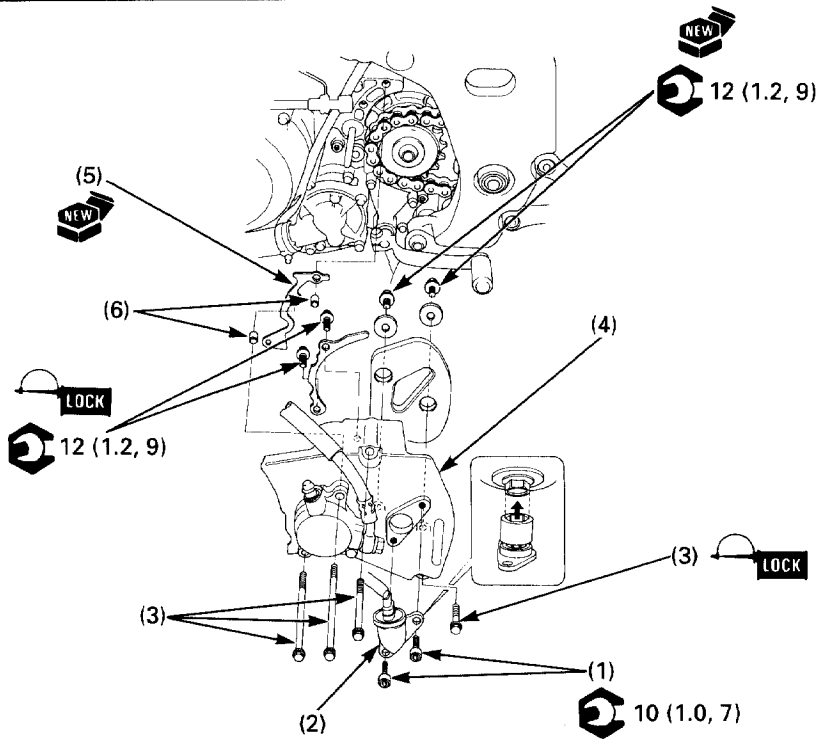

**Requisite Service**

- Lower fairing removal/installation (page 2-7)

Procedure		Q'ty	Remarks
(1)	<b>Removal Order</b> Bolt	2	Installation is in the reverse order of removal.  When installing, fit the hexagonal joint on the drive sprocket bolt head.
(2)	Speed sensor	1	
(3)	Bolt	4	
(4)	Drive sprocket cover	1	
(5)	Gasket	1	
(6)	Dowel pin	2	

# Gearshift Linkage Removal/Installation

(9) SHIFTER  
PLATE ASSEMBLY

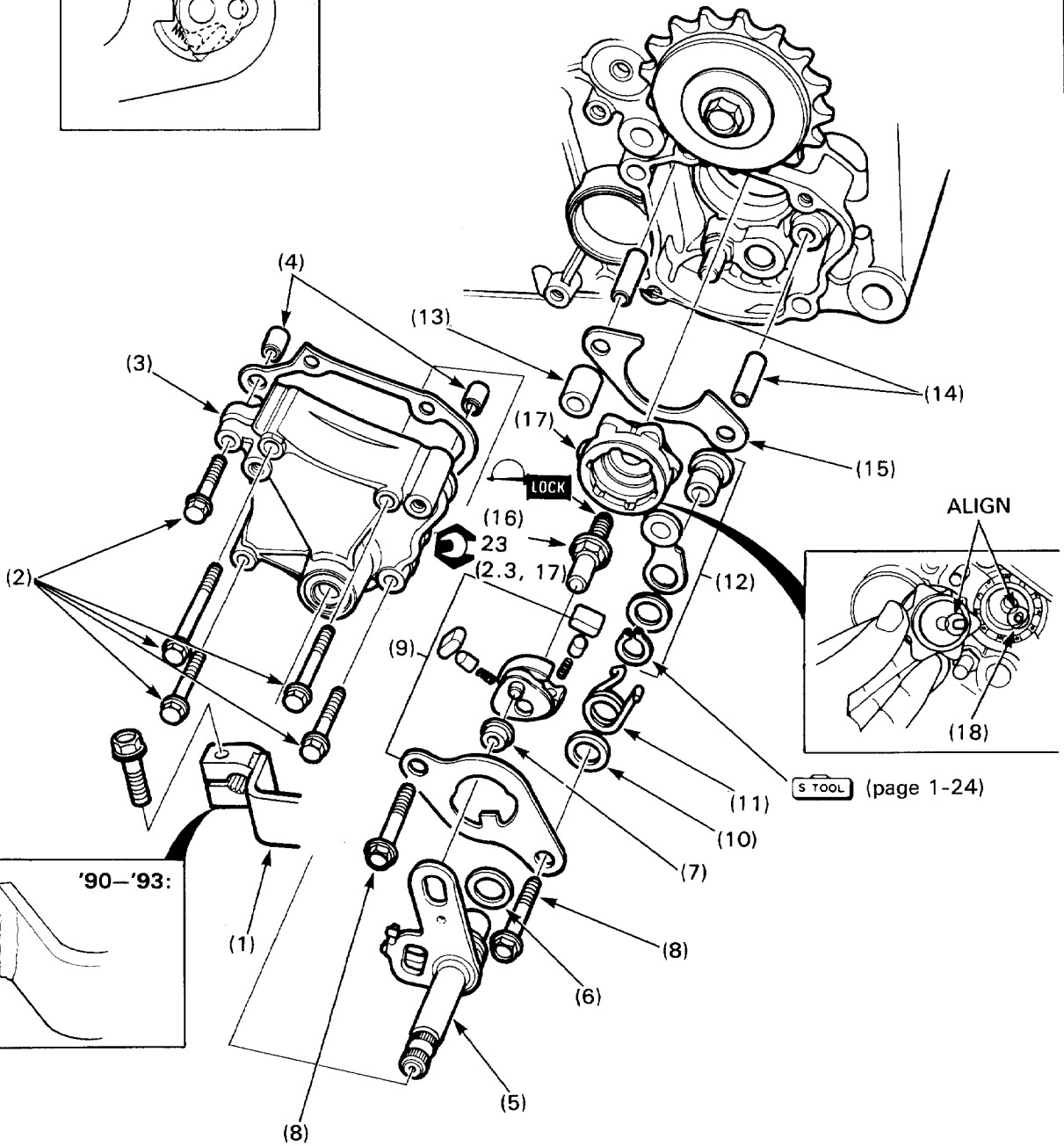
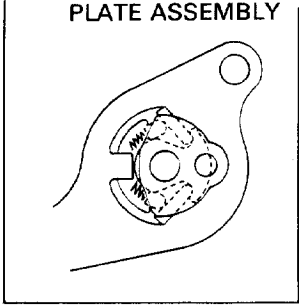

**NOTE**

- Gearshift linkage service can be performed with the engine in the frame.
- When removing the water pump, it is not necessary to disconnect the water hoses.
- After installing the gearshift linkage, make sure it operates properly.

**Requisite Service**

- Lower fairing removal/installation (page 2-7)
- Drive sprocket cover removal/installation (page 10-2)
- Water pump removal/installation (page 5-7)

Procedure		Q'ty	Remarks
<b>Removal Order</b>			
(1)	Gearshift pedal	1	• Installation is in the reverse order of removal. Install with the punch marks aligning with the gearshift spindle punch marks.
(2)	Gearshift linkage cover bolt	5	
(3)	Gearshift linkage cover	1	NOTE: • When removing and installing, clear the frame by turning the linkage cover slightly clockwise.
(4)	Gasket	1	
(5)	Gearshift spindle/return spring	1/1	Install by fitting the hole in the spindle with the shifter collar, and the return spring with the return spring pin.
(6)	Washer		
(7)	Shifter collar	1	
(8)	Shifter plate attaching bolt	2	
(9)	Shifter plate assembly	1	Lubricate each part with engine oil, and assemble as illustrated. Install on the shift drum center with the drum center positioned at any gear stop except neutral.
(10)	Washer	1	
(11)	Stopper arm spring	1	
(12)	Stopper arm assembly	1	Install the snap ring with the chamfered side facing inside, and seat fully in the flange collar groove.
(13)	Collar	1	
(14)	Dowel pin	2	
(15)	Shift drum bearing stopper plate	1	
(16)	Shift drum center bolt	1	Apply a locking agent to the threads.
(17)	Shift drum center	1	Install by aligning the cut out with the dowel pin as shown.
(18)	Dowel pin	1	



# 11. Crankshaft/Piston/Transmission

Service Information	11-1	Crankshaft Bearing Replacement	11-8
Troubleshooting	11-1	Transmission Removal/Installation	11-10
Crankcase Separation	11-2	Mainshaft Disassembly/Assembly	11-12
Crankshaft/Connecting Rod Removal/Installation	11-4	Countershaft Disassembly/Assembly	11-14
Piston Disassembly/Assembly	11-6	Crankcase Installation	11-16

## Service Information

- Remove the engine and separate the crankcase to inspect the crankshaft, connecting rod and transmission.
- Service Points

Service Item	Removed Components
Connecting rod	<ul style="list-style-type: none"> <li>• Cylinder head (page 8-4)</li> <li>• Piston (page 11-4)</li> <li>• Crankcase separation (page 11-2)</li> </ul>
Crankshaft	<ul style="list-style-type: none"> <li>• Starter clutch (page 17-10)</li> <li>• Flywheel (page 15-7)</li> <li>• Crankcase separation (page 11-2)</li> <li>• Connecting rod bearing cap (page 11-4)</li> </ul>
Transmission	<ul style="list-style-type: none"> <li>• Crankcase separation (page 11-2)</li> <li>• Gearshift linkage (page 10-4)</li> <li>• Clutch (page 9-3)</li> </ul>

11

- Prior to assembling the crankcase halves, apply a sealant to their mating surface. Wipe off excess sealant thoroughly.
- Mark and store the bearing inserts to be sure of their correct locations for reassembly. If the inserts are improperly installed they will block the oil holes, causing insufficient lubrication and eventual engine seizure.

## Troubleshooting

### Excessive noise

- Worn connecting rod bearings
- Bent connecting rod
- Worn crankshaft main bearing

### Hard to shift

- Improper clutch operation
- Incorrect engine oil viscosity
- Incorrect clutch adjustment
- Bent shift forks
- Bent fork shaft
- Bent shift fork claw
- Damaged shift drum cam grooves
- Bent shift spindle

### Transmission jumps out of gear

- Worn gear engagement dogs or slots
- Bent shift fork shaft
- Damaged shift drum stopper arm
- Damaged or bent shift fork
- Broken shift linkage return spring
- Damaged shift drum cam grooves

### Compression too high

- Excessive carbon build-up on piston top or combustion chamber

### Abnormal noise (piston)

- Worn cylinder and piston
- Worn piston pin or piston pin hole
- Worn connecting rod big end bearing

# Crankcase Separation

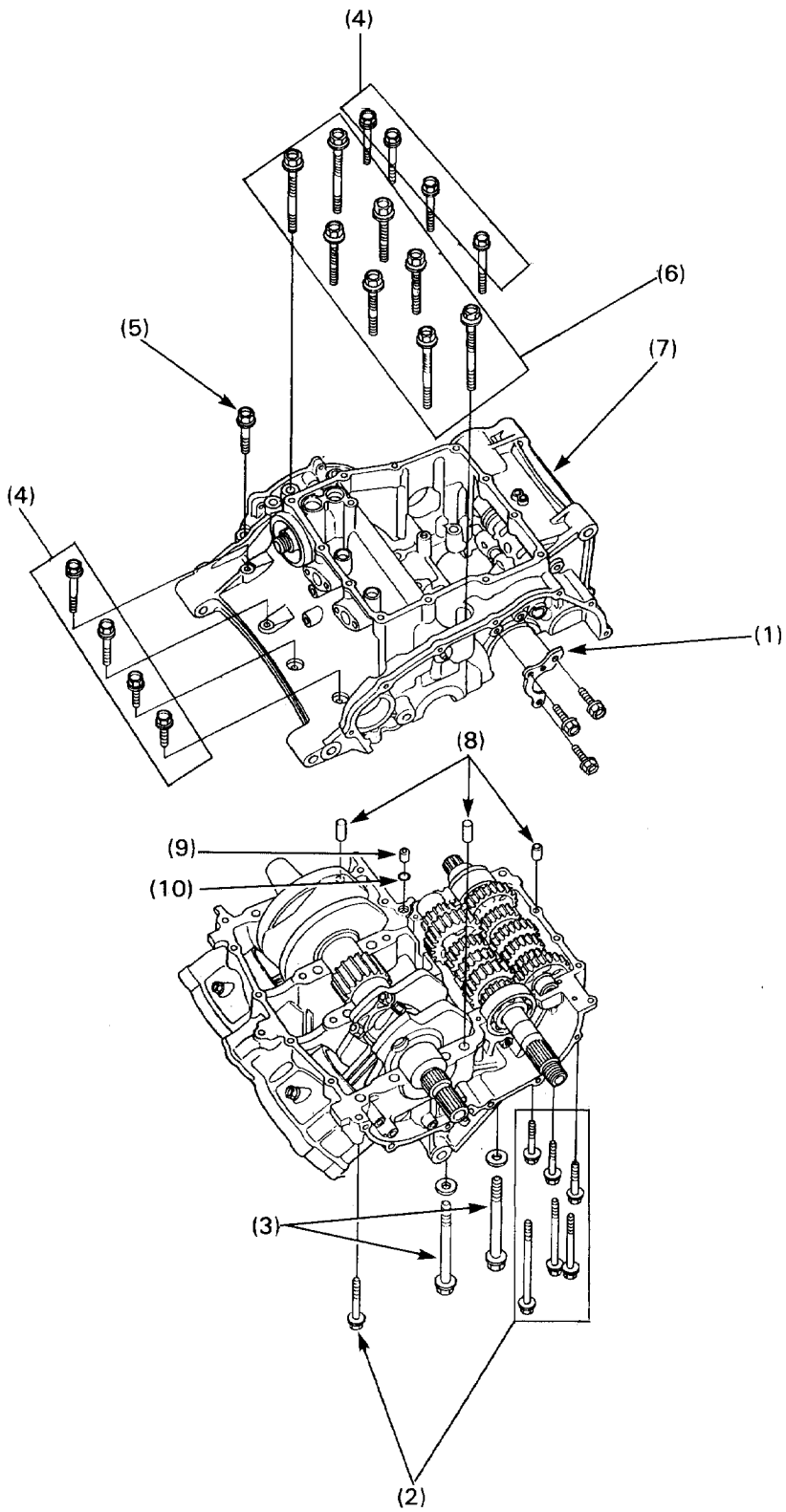

## NOTE

- Before removing the parts, make a note of their location for correct reinstallation.

**Requisite Service**

- Engine removal (page 7-2)
- Alternator cover removal (page 15-7)
- Clutch removal (page 9-3)
- Oil pump removal (page 4-3)

Procedure		Q'ty	Remarks
<b>Upper Case Side</b>			
(1)	Mainshaft bearing stopper plate	1	Loosen gradually.
(2)	6mm bolt	7	
(3)	10mm bolt	2	
<b>Lower Case Side</b>			
(4)	6mm bolt	8	Loosen in a gradual, crisscross pattern.
(5)	8mm bolt	1	Loosen in a gradual, crisscross pattern.
(6)	9mm bolt	8	
(7)	Lower crankcase		Before separating the crankcase halves, remove all crankcase bolts.
(8)	Dowel pin	3	
(9)	Oil orifice	1	
(10)	O-ring	1	

# Crankshaft/Connecting Rod Removal/Installation

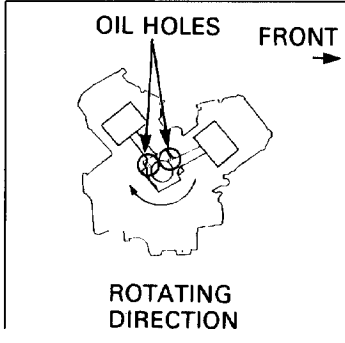
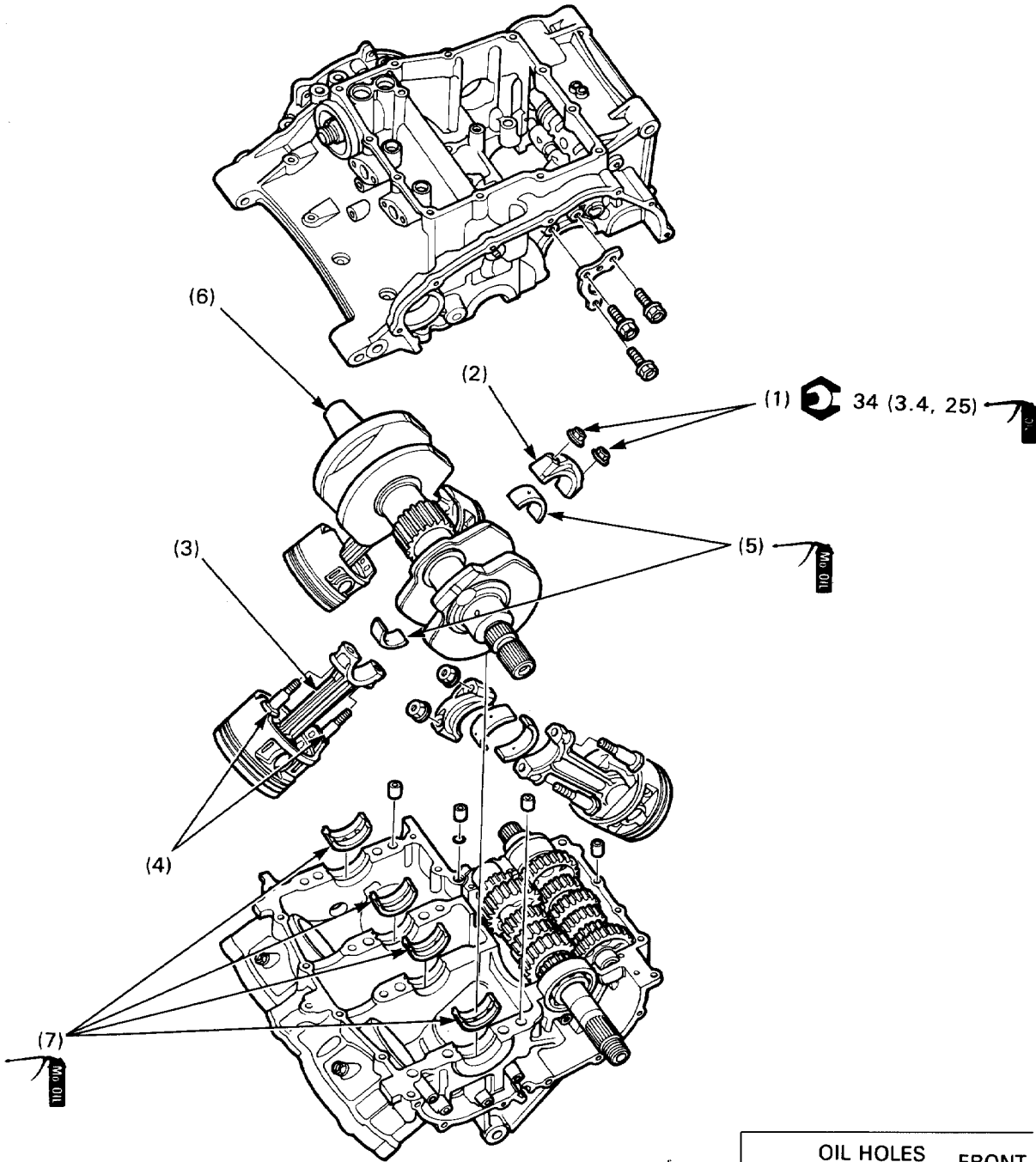

## NOTE

- Determine the replacement bearing color code according to the main bearing selection table (page 11-8) or the connecting rod bearing selection table (page 11-9).
- Mark and store the bearing inserts to be sure of their correct locations for reassembly.
- At installation, apply molybdenum solution to the main journal bearing and connecting rod bearing surface.
- Refer to page 1-8 for crankshaft and rod specification.
- Refer to section 14 of the Common Service Manual for bearing inspection.

**Requisite Service**

- Refer to Service Information (page 11-1)

Procedure		Q'ty	Remarks
<b>Removal Order</b>			
(1)	Connecting rod bearing cap nut	8	
(2)	Bearing cap	4	
(3)	Connecting rod	4	
(4)	Connecting rod bolt	8	Do not remove them without necessity.
(5)	Connecting rod bearing	8	Wipe all oil from the bearing seating areas.
(6)	Crankshaft	1	
(7)	Crankshaft main journal bearing	12	Wipe all oil from the bearing seating areas.
<b>Installation Order</b>			
(7)	Crankshaft main journal bearing	12	The bearing tabs should be aligned with the grooves in the crankcases.
(6)	Crankshaft	1	Install it onto the upper crankcase with the flywheel side facing the clutch.
(5)	Connecting rod bearing	8	NOTE: • The bearing oil hole should be aligned with the oil hole in the connecting rod.
(4)	Connecting rod bolt	8	
(3)	Connecting rod	4	NOTE: • Be sure the connecting rods are installed in their original positions and oil holes are facing opposite the rotating direction of the crankshaft. • Each connecting rod has an identification mark; "ML7-F" (front), "ML7-R" (rear). Install them in the correct cylinder.
(2)	Bearing cap	4	Install them after doublechecking that the correct bearings and rods are in place.
(1)	Connecting rod bearing cap nut	8	Apply oil to the nut threads and torque them in gradual, crisscross pattern.

# Piston Disassembly/Assembly

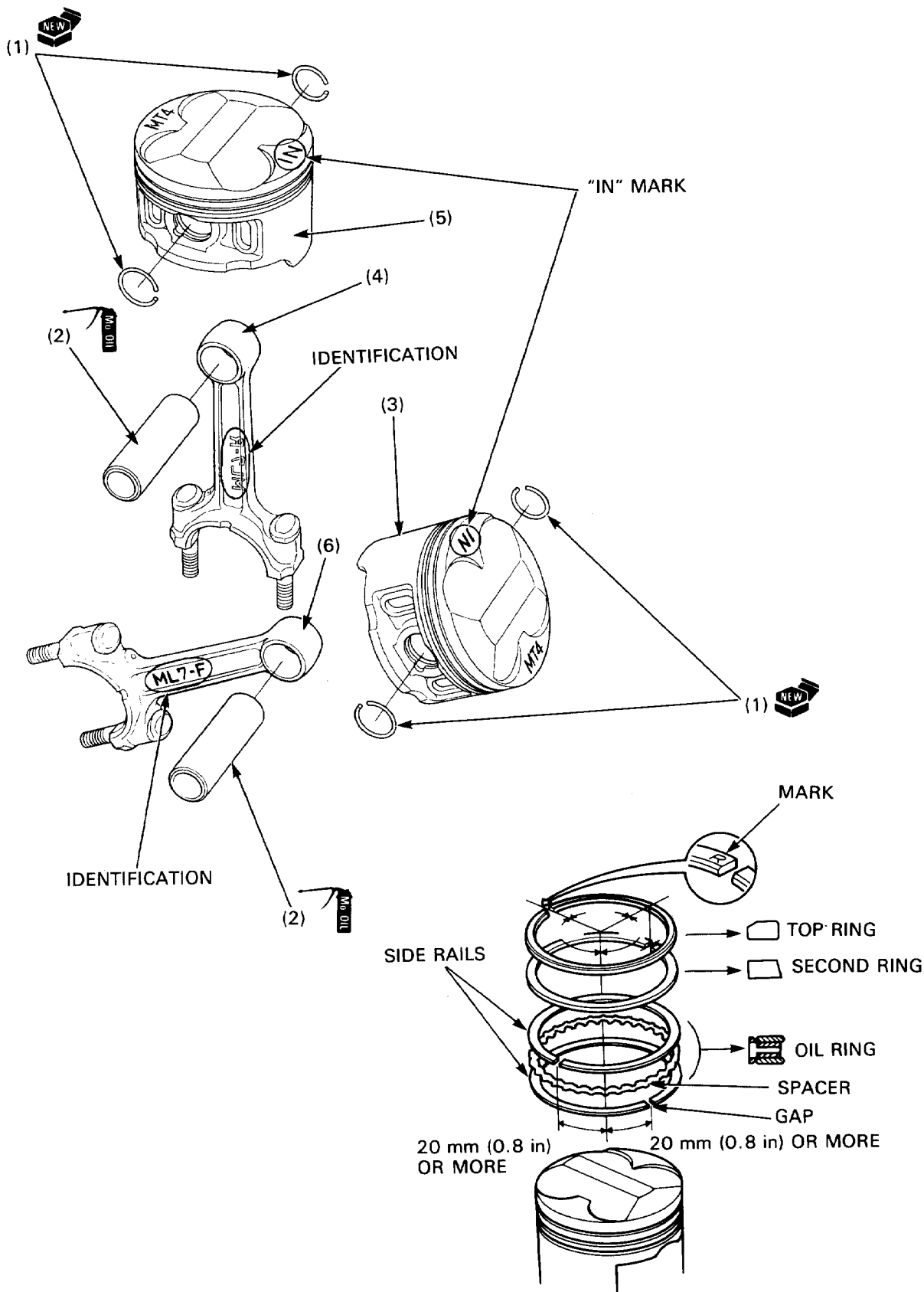

**CAUTION**

- At installation, apply molybdenum oil solution to the piston sliding surface.

**Requisite Service**

- Piston removal (page 11-4)

Procedure		Q'ty	Remarks
	<b>Disassembly Order</b>		
(1)	Piston pin clip	8	<ul style="list-style-type: none"> <li>• Assembly is in the reverse order of disassembly.</li> </ul> <b>NOTE:</b> <ul style="list-style-type: none"> <li>• Install securely in the piston groove so the clip end does not align with the cut out in the piston.</li> </ul>
(2)	Piston pin	4	At installation, apply molybdenum solution to the sliding surface.
(3)	Front piston	2	Distinguish the front connecting rod by the identification "ML7-F". Install the piston on the front connecting rod so that the "IN" mark on the piston head faces the connecting rod oil hole side. It is not necessary to remove the piston rings unless they need replacing.
(4)	Front connecting rod	2	
(5)	Rear piston	2	Distinguish the rear connecting rod by the identification "ML7-R". Install the piston on the rear connecting rod so that the "IN" mark on the piston head faces the side opposite the connecting rod oil hole. It is not necessary to remove the piston rings unless they need replacing.
(6)	Rear connecting rod	2	

# Crankshaft Bearing Replacement

## Main Journal Bearing Selection

Record the crankcase I.D. code letters from the pad on the right side of the upper crankcase.

**NOTE**

- The letters (A, B or C) on the upper crankcase are the codes for the main journal I.D.s. from the left to right.

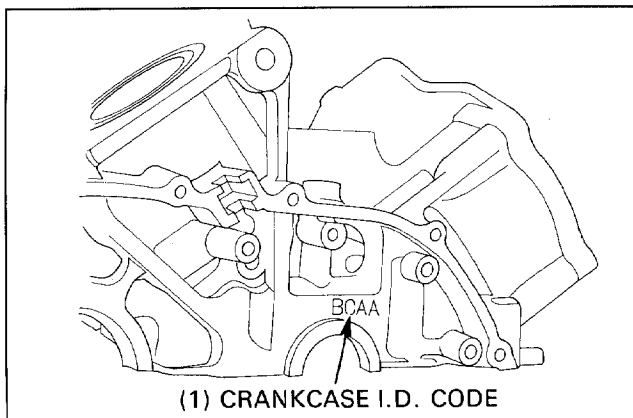

Record the corresponding main journal O.D. code numbers from the crank weight.

**NOTE**

- The numbers (1, 2 or 3) on the crank weight are the codes for the main journal O.D.s.

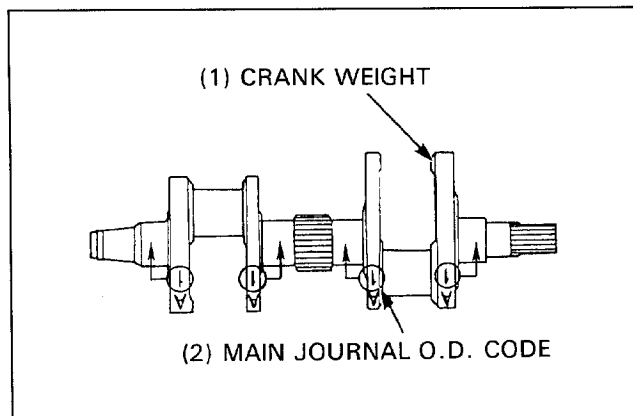

Cross-reference the case and journal codes to determine the replacement bearing color codes.

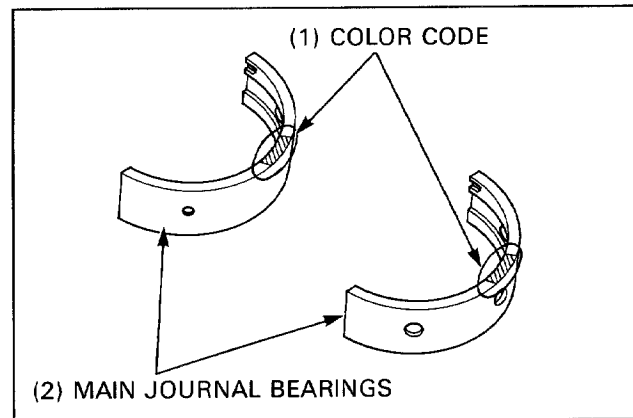

**Main Journal Bearing Selection Table:**

'90-'93: Unit: mm (in)

Crankcase I.D. code		A	B	C
Main journal O.D. code		37.000-37.005 (1.4567-1.4569)	37.006-37.011 (1.4569-1.4572)	37.012-37.018 (1.4572-1.4574)
1	33.998-34.003 (1.3385-1.3387)	Yellow	Green	Brown
2	33.992-33.997 (1.3383-1.3385)	Green	Brown	Black
3	33.985-33.991 (1.3380-1.3382)	Brown	Black	Blue

After '93:

Crankcase I.D. code		A	B	C
Main journal O.D. code		37.000-37.005 (1.4567-1.4569)	37.006-37.011 (1.4569-1.4572)	37.012-37.018 (1.4572-1.4574)
1	34.007-34.013 (1.3389-1.3391)	Yellow	Green	Brown
2	34.001-34.006 (1.3386-1.3388)	Green	Brown	Black
3	33.995-34.000 (1.3368-1.3385)	Brown	Black	Blue

Bearing thickness:

- Blue: Thick
- Black:
- Brown:
- Green:
- Yellow: Thin

### Connecting Rod Bearing Selection

Record the connecting rod I.D. code numbers on the rod.

**NOTE:**

- Numbers (1, 2 or 3) on the connecting rod are the codes for the connecting rod I.D.s.

Record the crankpin O.D. code letters from the crank weight.

**NOTE:**

- Letters (A, B or C) on the crank weight are the codes for the crankpin O.D.s.

**NOTE:**

- Distinguish between the front and rear connecting rod bearing. One painted mark on the front connecting rod and two painted marks on the rear.

Cross reference the crankpin and rod codes to determine the replacement bearing color code.

Connecting rod I.D. Code	1		2		3	
	Front	Rear	Front	Rear	Front	Rear
A 35.995-36.000mm (1.4171-1.4173in)	Yellow	Yellow	Green	Green	Brown	Brown
B 35.989-35.994mm (1.4169-1.4171in)	Green	Green	Brown	Brown	Black	Black
C 35.982-35.988mm (1.4166-1.4169in)	Brown	Brown	Black	Black	Blue	Blue

Bearing thickness

- Blue: Thick
- Black: ↑
- Brown: ↑
- Green: ↓
- Yellow: Thin

### Connecting Rod Selection

If a connecting rod requires replacement, you should select a rod with the same weight code as the original. But if that is unavailable, you may use one of the others specified in the chart on next page.

Original rod code (The rod you must be replace)	Other rod code on that same crankpin	Replacement rod code
A	B	A, B or C
	C	A or B
B	A	B or C
	C	A or B
C	A	B or C
	B	A, B or C

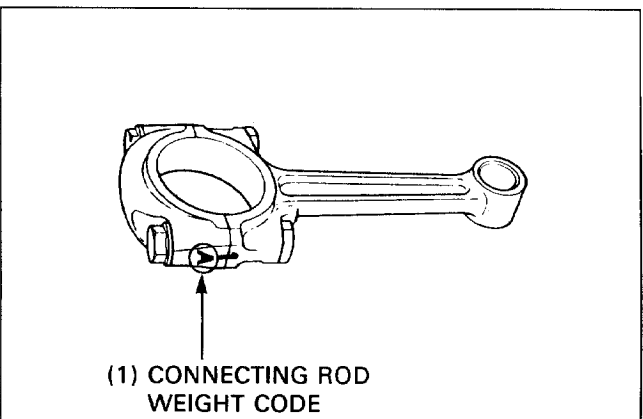
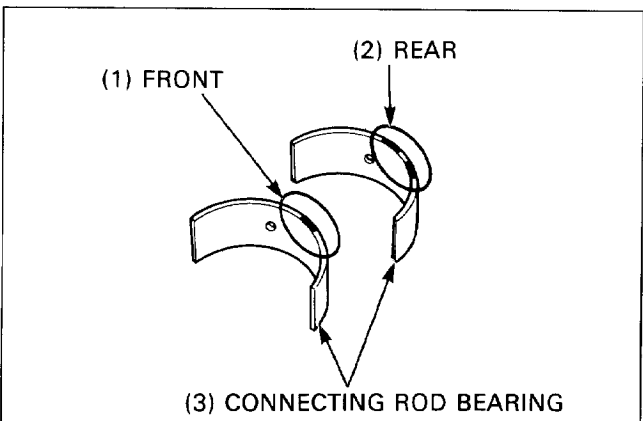
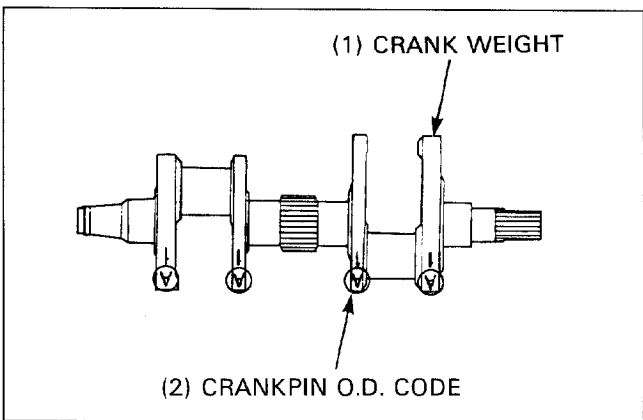
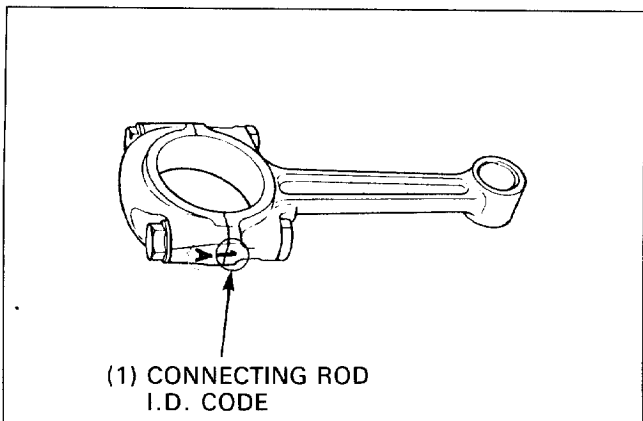

# Transmission Removal/Installation

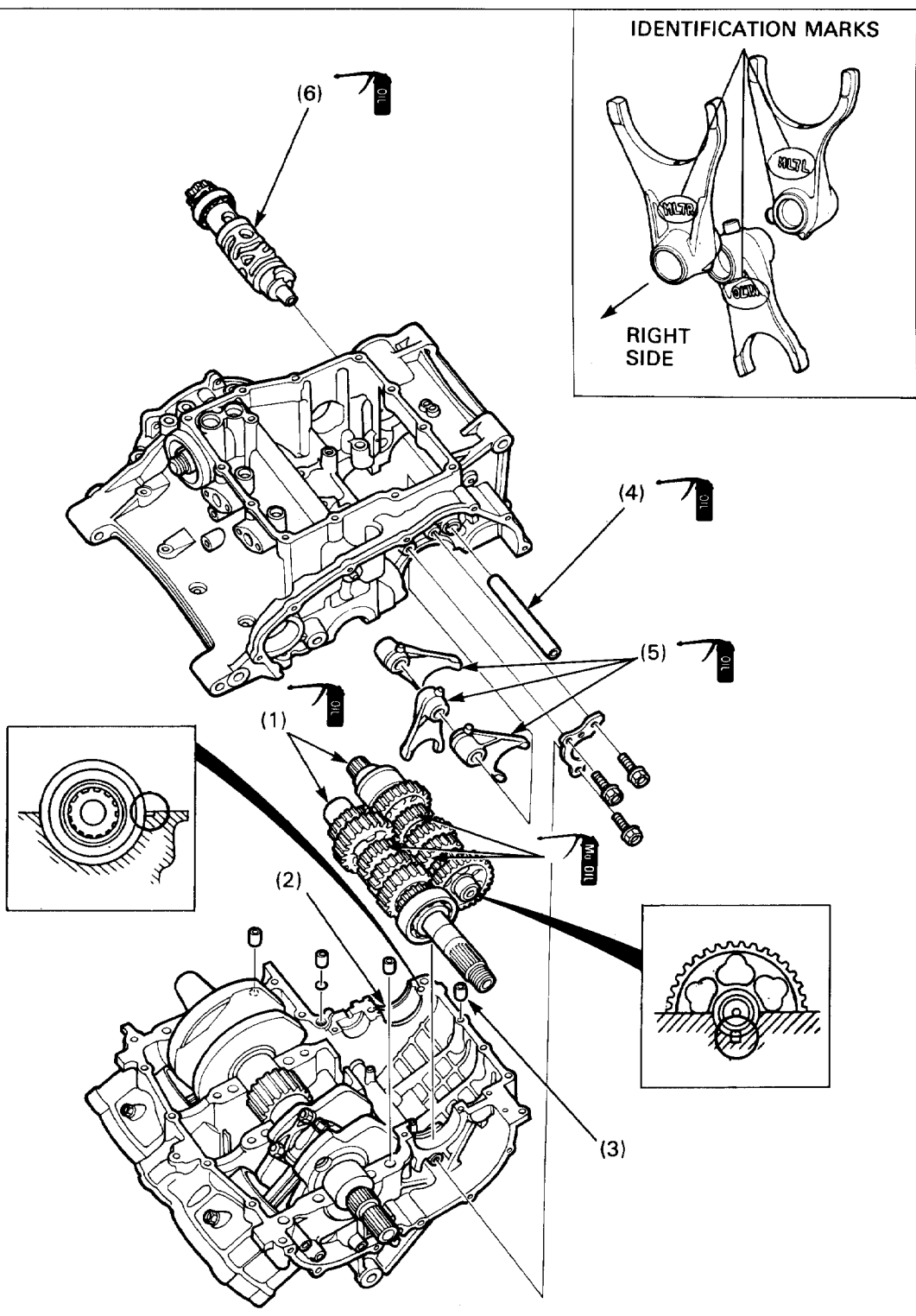

IDENTIFICATION MARKS

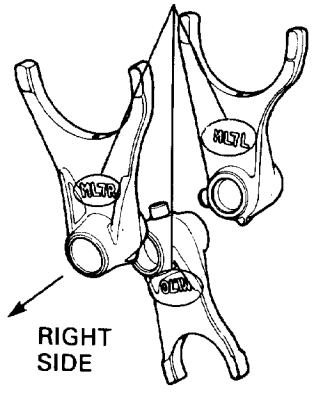



**Requisite Service**

- Refer to Service Information (page 11-1)

Procedure	Q'ty	Remarks
(1) <b>Removal Order</b>		
(1) Mainshaft/countershaft assembly	1/1	<ul style="list-style-type: none"> <li>• Installation is in the reverse order of removal.</li> </ul> <b>NOTE:</b> <ul style="list-style-type: none"> <li>• At installation, fit the countershaft bearing set pin and plate in the upper crankcase groove, and the dowel pin in the hole in the needle bearing case.</li> </ul>
(2) Countershaft bearing set plate	1	<b>CAUTION:</b>
(3) Dowel pin	3	<ul style="list-style-type: none"> <li>• Fit in the upper crankcase securely.</li> </ul>
(4) Shift fork shaft	1	
(5) Shift fork	3	Install them with the identification mark (R: Right, C: Center, L: Left) side facing the right side as shown.
(6) Shift drum	1	

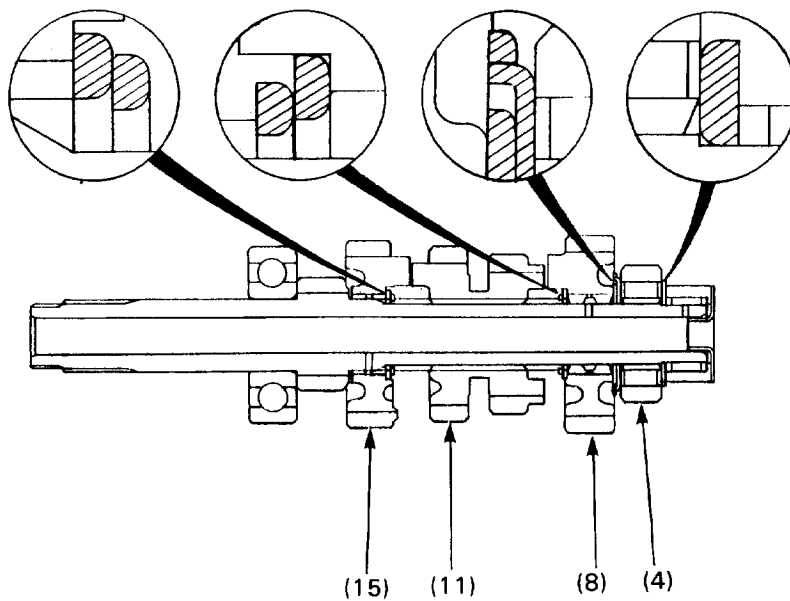
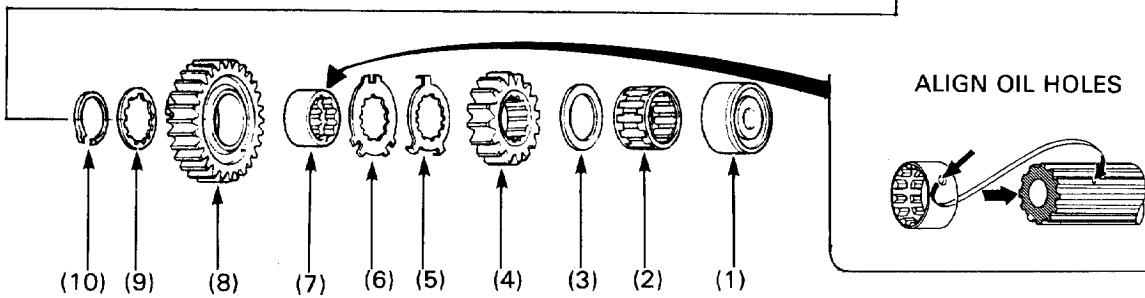
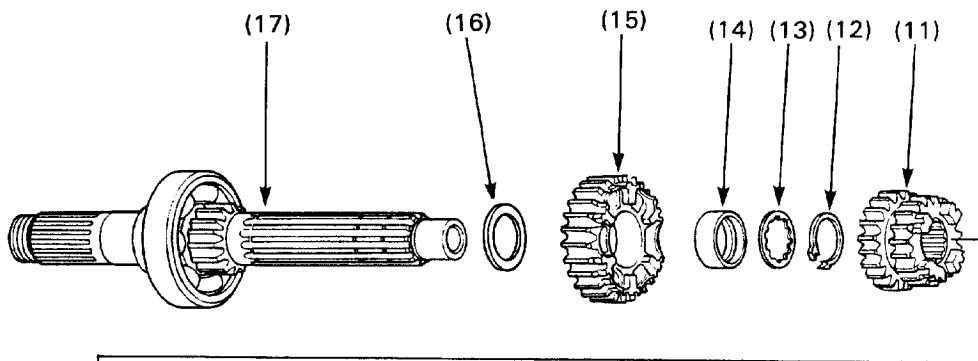
# Mainshaft Disassembly/Assembly



-  : SHIFTER GEAR GROOVE
-  : GEAR SLIDING SURFACE

## NOTE

- Apply molybdenum oil solution to the shifter gear grooves. Apply oil to all sliding surfaces of the mainshaft, countershaft and bushings.
- Install the thrust washers and snap rings with the chamfered edge facing the thrust load side.
- Refer to section 13 of the Common Service Manual for inspection information.

**Requisite Service**

- Transmission removal/installation (page 11-10)

Procedure	Q'ty	Remarks
<b>Disassembly Order</b>		• Assembly is in the reverse order of disassembly.
(1) Needle bearing case	1	
(2) Needle bearing	1	
(3) Thrust washer	1	
(4) M2 gear (16T)	1	
(5) Tanged washer	1	At assembly, fit the tangs into the lock washer cut-outs.
(6) Lock washer	1	
(7) M6 spline bushing	1	Align the oil holes of the bushing and mainshaft.
(8) M6 gear (28T)	1	
(9) Spline washer	1	
(10) Snap ring	1	
(11) M3/M4 gear (19/21T)	1	
(12) Snap ring	1	
(13) Spline washer	1	
(14) M5 bushing	1	
(15) M5 gear (26T)	1	
(16) Washer	1	
(17) Mainshaft/M1 gear (13T)	1	

# Countershaft Disassembly/Assembly

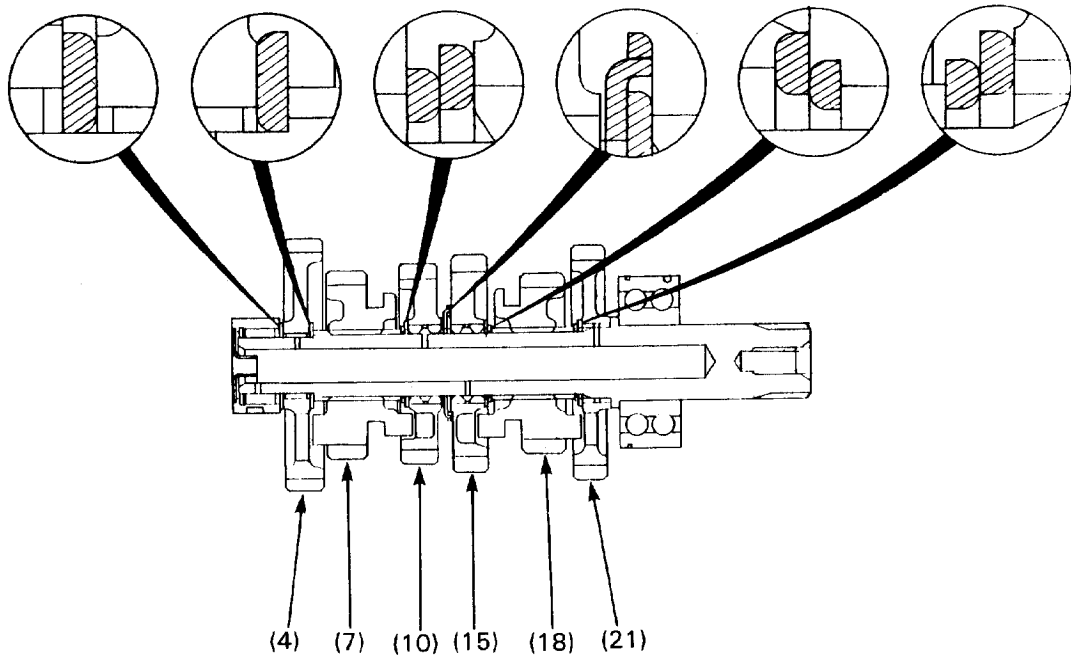
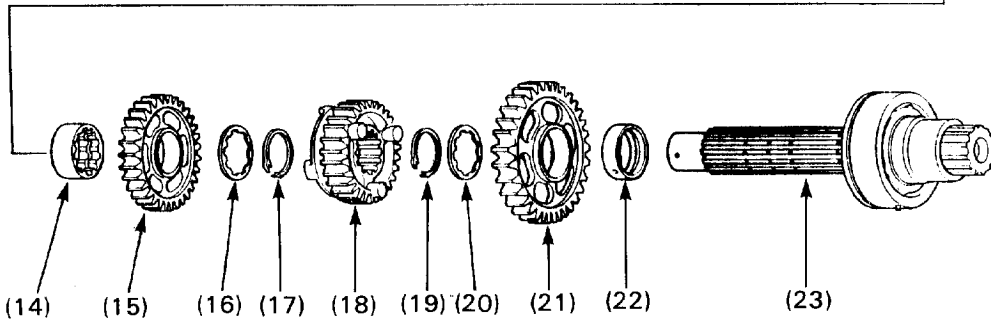
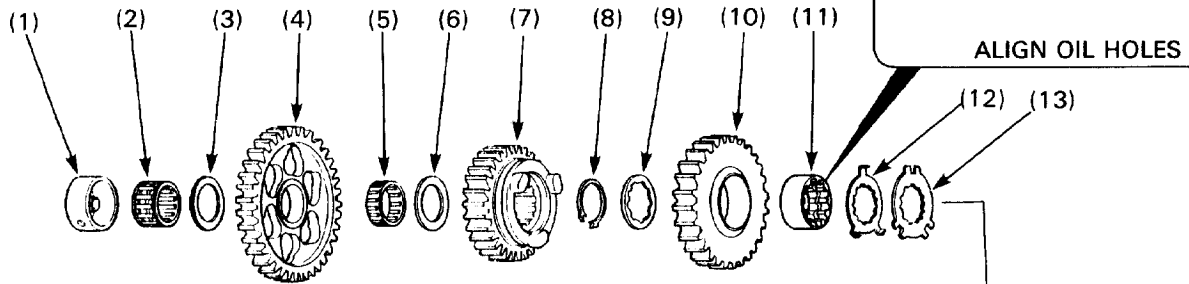

-  : SHIFTER GEAR GROOVE
-  : GEAR SLIDING SURFACE

## NOTE

- Apply molybdenum oil solution to the shifter gear grooves. Apply oil to all sliding surfaces of the mainshaft, countershaft and bushings.
- Install the thrust washers and snap rings with the chamfered edge facing to the thrust load side.
- Refer to section 13 of the Common Service Manual for inspection information.

**Requisite Service**

- Transmission removal/installation (page 11-10)

Procedure		Q'ty	Remarks
	<b>Disassembly Order</b>		• Assembly is in the reverse order of disassembly.
(1)	Needle bearing case	1	
(2)	Needle bearing	1	
(3)	Thrust washer	1	
(4)	C1 gear (37T)	1	
(5)	Needle bearing	1	
(6)	Thrust washer	1	
(7)	C5 gear (30T)	1	
(8)	Snap ring	1	
(9)	Spline washer	1	
(10)	C4 gear (28T)	1	
(11)	C4 spline bushing	1	Align the oil holes of the bushing and countershaft.
(12)	Tanged washer	1	At assembly, fit the tangs into the lock washer cut-outs.
(13)	Lock washer	1	
(14)	C3 spline bushing	1	
(15)	C3 gear (31T)	1	
(16)	Spline washer	1	
(17)	Snap ring	1	
(18)	C6 gear (29T)	1	
(19)	Snap ring	1	
(20)	Spline washer	1	
(21)	C2 gear (33T)	1	
(22)	C2 bushing	1	
(23)	Countershaft	1	

# Crankcase Installation

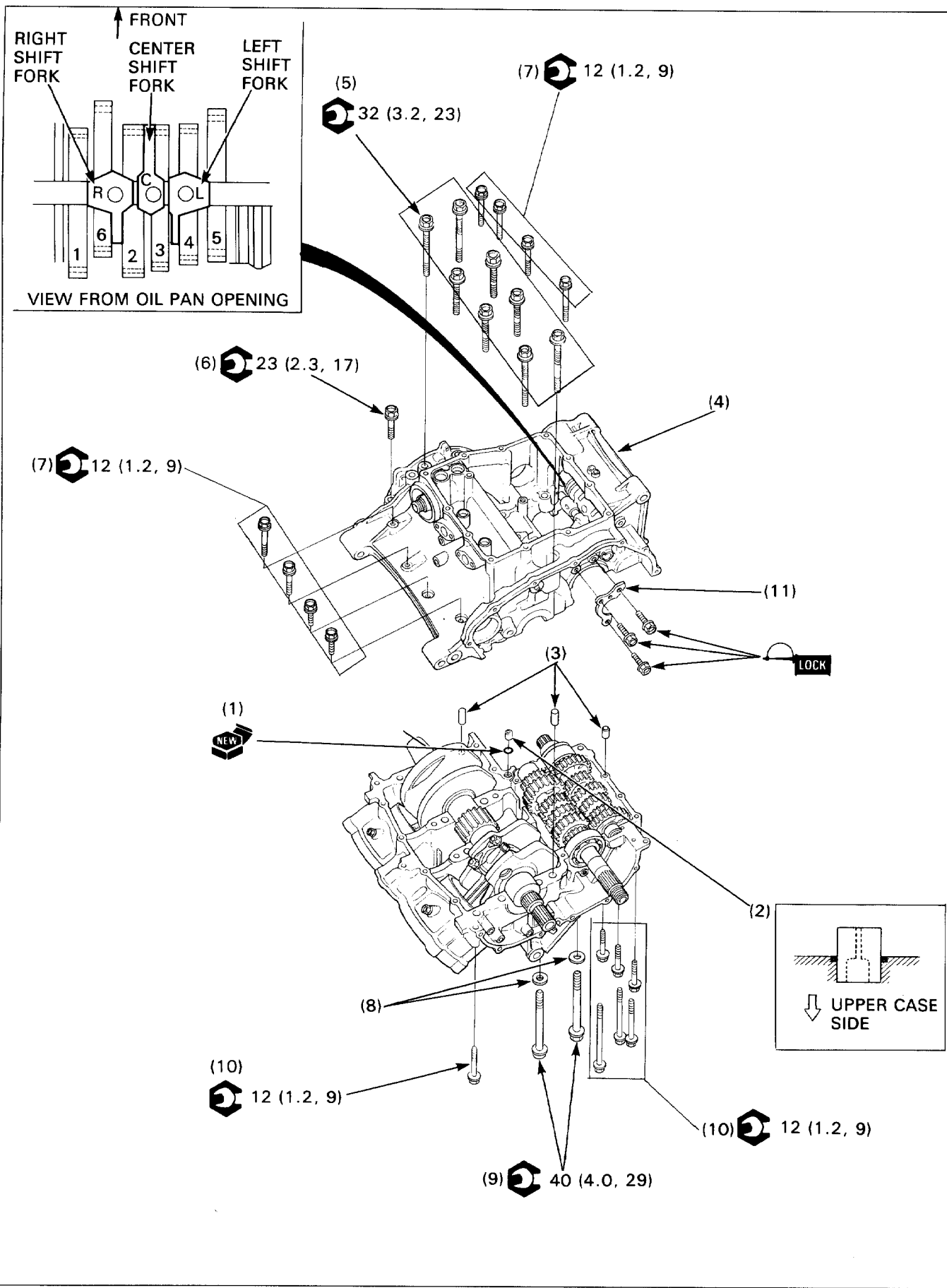

**CAUTION**

- Do not apply sealant to the area near the main bearings.
- Install the oil orifice with the larger inner diameter side facing the upper crankcase.
- If the lower crankcase installation is difficult, make sure the transmission assembly is installed correctly.

**NOTE**

- Refer to page 11-18 for crankcase bolt location.

**Requisite Service**

- Oil pump installation (page 4-3)
- Starter motor installation (page 17-7)
- Alternator installation (page 15-7)
- Clutch installation (page 9-4)
- Gearshift linkage installation (page 10-2)
- Cylinder head/camshaft idle gear case installation (page 8-4)
- Engine installation (page 7-2)

Procedure		Q'ty	Remarks
<b>Lower Case Side</b>			
(1)	O-ring	1	
(2)	Oil orifice	1	Install it as illustrated.
(3)	Dowel pin	3	
(4)	Lower crankcase	1	After installation, make sure shift forks engage properly with the corresponding gears.
(5)	9mm bolt	8	Tighten in a gradual, crisscross pattern. Apply engine oil to the threads and seating surface.
(6)	8mm bolt	1	
(7)	6mm bolt	8	Tighten in a gradual, crisscross pattern.
<b>Upper Case Side</b>			
(8)	Sealing washer	2	
(9)	10mm bolt	2	Tighten gradually.
(10)	6mm bolt	7	
(11)	Mainshaft bearing stopper plate	1	Apply a locking agent to the threads of the attaching bolts.

**Crankcase Bolts Location**

Install the crankcase bolts and sealing washers as shown.

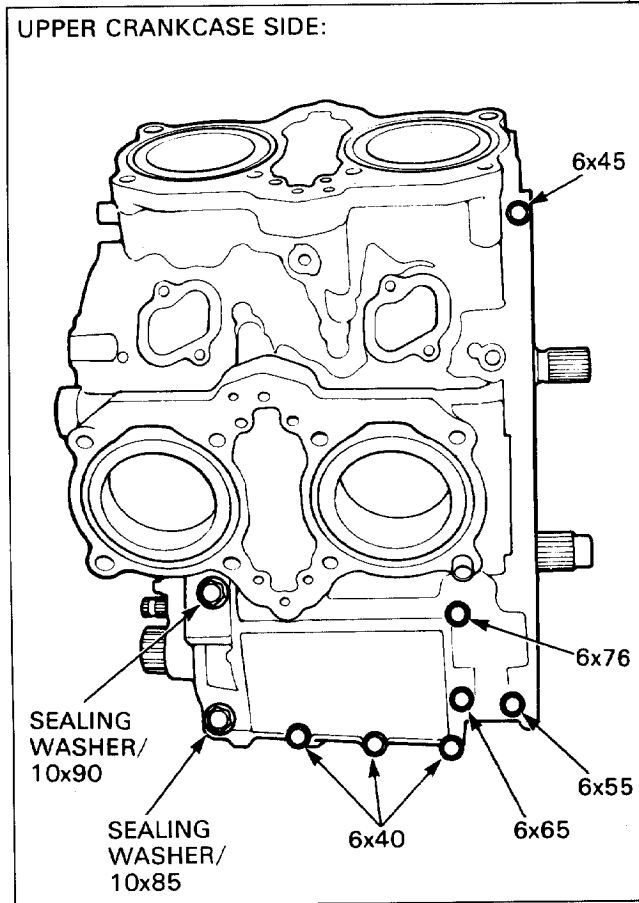
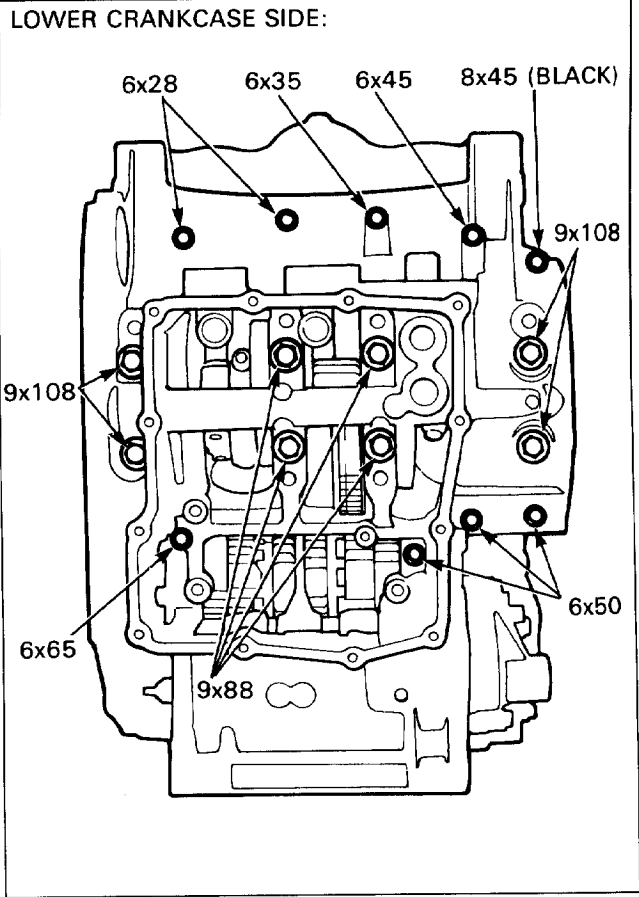

# 12. Front Wheel/Suspension/Steering

Service Information	12-1	Front Wheel Disassembly/ Assembly	12-6
Troubleshooting	12-1	Fork Removal/Installation	12-8
Right Handlebar Removal/ Installation	12-2	Fork Disassembly	12-10
Left Handlebar Removal/ Installation	12-3	Fork Assembly	12-14
Front Wheel Removal/ Installation	12-4	Steering Stem Removal/ Installation	12-18

## Service Information

### ⚠ WARNING

- Riding on damaged rims impairs safe operation of the vehicle.
- A contaminated brake disc or pad reduces stopping power. Discard contaminated pads and clean a contaminated disc with a high quality brake degreasing agent.
- Inhaled asbestos fibers have been found to cause respiratory disease and cancer. Never use an air hose or dry brush to clean brake assemblies. Use an OSHA-approved vacuum cleaner or alternate method approved by OSHA designed to minimize the hazard caused by airborne asbestos fibers.

- Refer to the section 14 for brake system information.
- Refer to the section 18 for light, meter and switch information.
- Tubeless tire removal, repair, and remounting procedures are covered in the section 16 of the Common Service Manual.
- If the motorcycle has been involved in an accident, inspect the frame very carefully at the steering head and at the engine mounts. These are the areas most likely to suffer damage. It is possible to bend the frame steering head without bending the fork tubes or even the front axle.
- While removing the wheel, fork or steering stem, support the motorcycle securely with a jack or other support under the exhaust system.

12

## Troubleshooting

### Hard steering

- Steering head bearing adjustment nut too tight
- Faulty steering head bearings
- Damaged steering stem races
- Insufficient tire pressure
- Faulty tire

### Steers to one side or does not track straight

- Bent fork
- Bent front axle: wheel installed incorrectly
- Faulty steering head bearings
- Bent frame
- Worn wheel bearing
- Worn swingarm pivot

### Front wheel wobbling

- Bent rim
- Worn front wheel bearings
- Faulty tire
- Unbalanced tire and wheel

### Wheel turns hard

- Faulty wheel bearing
- Brake drag
- Bent front axle

### Soft suspension

- Weak fork spring
- Insufficient fluid in fork
- Low fluid level in fork
- Low tire pressure

### Hard suspension

- Incorrect fluid weight
- Bent fork tubes
- Clogged fork fluid passage
- High tire pressure

### Front suspension noisy

- Insufficient fluid in fork
- Loose fork fasteners

# Right Handlebar Removal/Installation

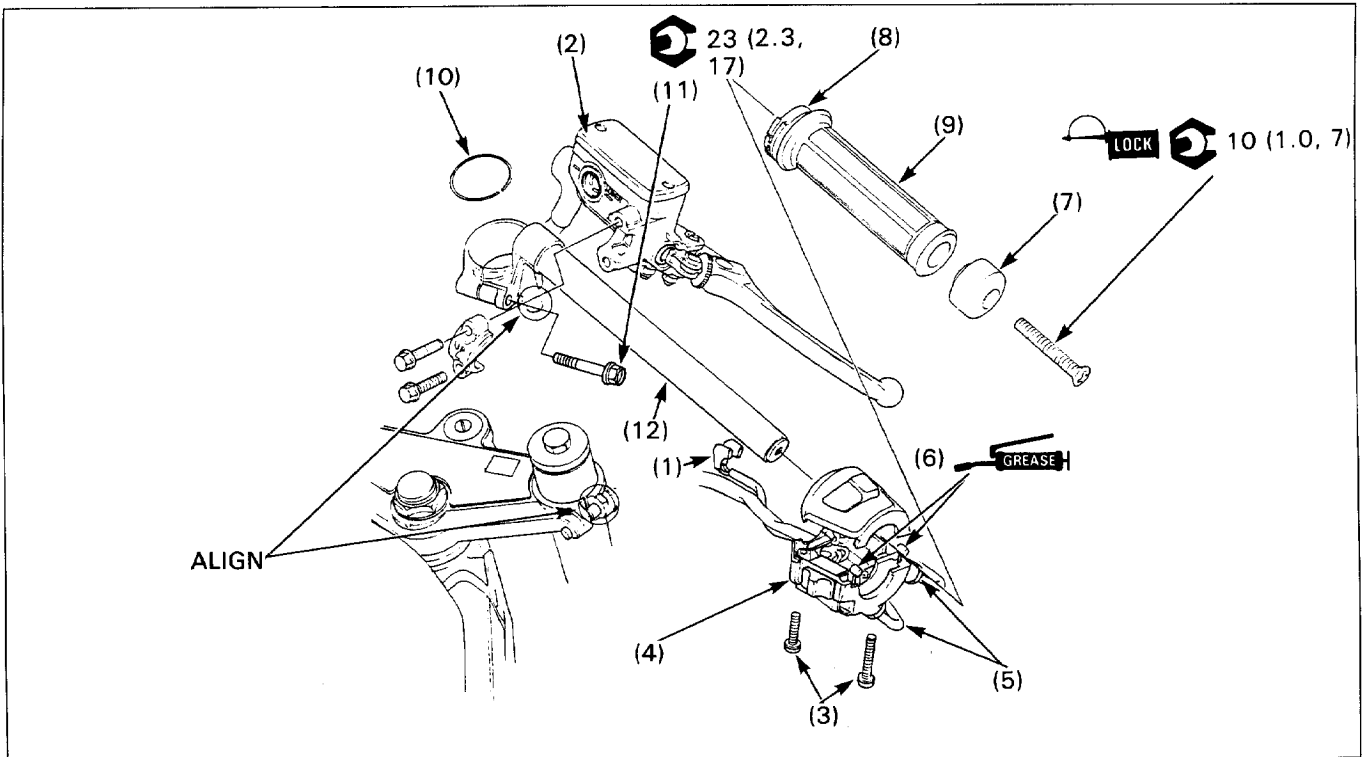

**NOTE**

- Using wires, hang the front brake master cylinder at least as high as the position it was originally installed at to prevent air from getting into the master cylinder. Do not twist the brake hose.
- Route the cables and wire harnesses properly (page 1-29).
- Adjust the throttle cable after installation.

Procedure	Q'ty	Remarks
<b>Removal Order</b>		• Installation is in the reverse order of removal.
(1) Front brake light switch connector	2	
(2) Master cylinder	1	Align the holder end with the punch mark on the handlebar and face the holder UP mark upward. Tighten the upper bolt first, then the lower bolt.
(3) Right handlebar switch housing screw	2	Tighten the front screw first, then the rear screw.
(4) Right handlebar switch housing	1	
(5) Throttle cable nut	1	
(6) Throttle cable	2	Don't bend or distort the cables.
(7) Handlebar weight	1	Align its boss with the inner weight.
(8) Throttle pipe	1	
(9) Throttle grip	1	Apply Honda Bond A to the inside surface of the grip.
(10) Stop ring	1	Install into the fork groove properly.
(11) Handlebar pinch bolt	1	Tight while pushing the handlebar forward.
(12) Right handlebar	1	Align the handlebar boss with the top bridge slot.

# Left Handlebar Removal/Installation

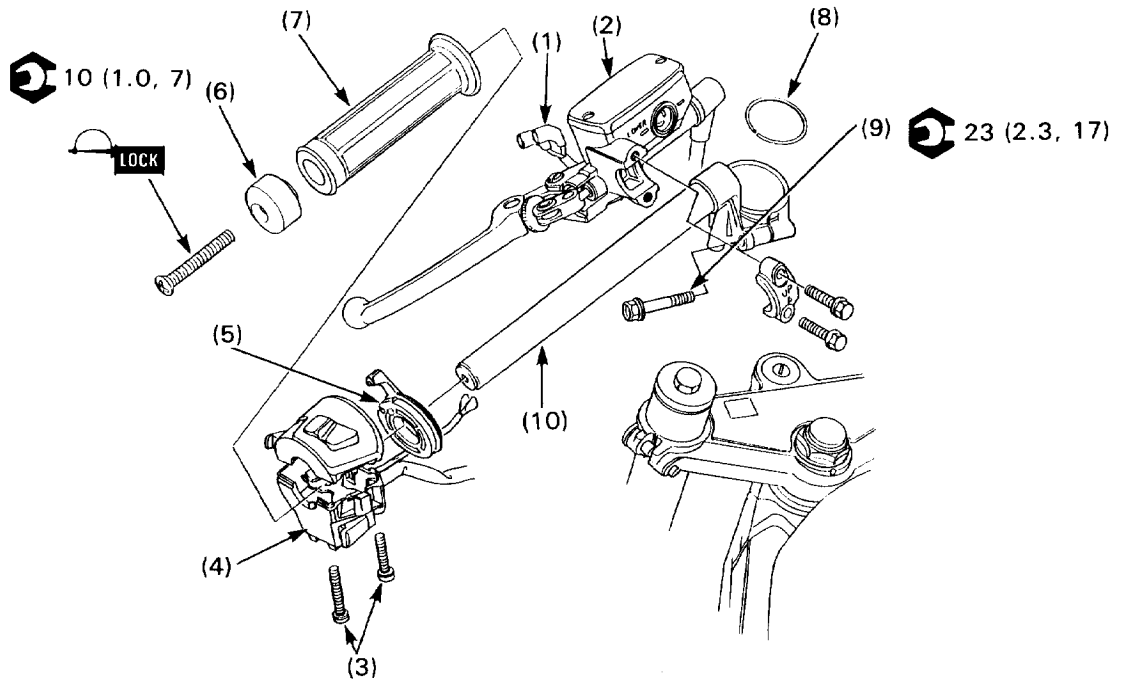

## NOTE

- Using wires, hang the clutch master cylinder at least as high as the position it was originally installed at to prevent air from getting into the master cylinder. Do not twist the clutch master cylinder hose.
- Route the choke cable and wire harness properly (page 1-29).

Procedure	Q'ty	Remarks
<b>Removal Order</b>		• Installation is in the reverse order of removal.
(1) Clutch switch connector	2	
(2) Clutch master cylinder assembly	1	Align the holder end with the punch mark on the handlebar and face the holder UP mark upward. Tighten the upper bolt first, then the lower bolt.
(3) Left handlebar switch housing screw	2	Tighten the front screw first, then the rear screw.
(4) Left handlebar switch housing	1	
(5) Choke cable lever	1	
(6) Handlebar weight	1	Align its boss with the inner weight.
(7) Handle grip	1	Apply Honda Bond A to the inside surface of the grip.
(8) Stop ring	1	Install into the fork groove properly.
(9) Handlebar pinch bolt	1	Tighten while pushing the handlebar forward.
(10) Left handlebar	1	Align the handlebar boss with the top bridge slot.

# Front Wheel Removal/Installation

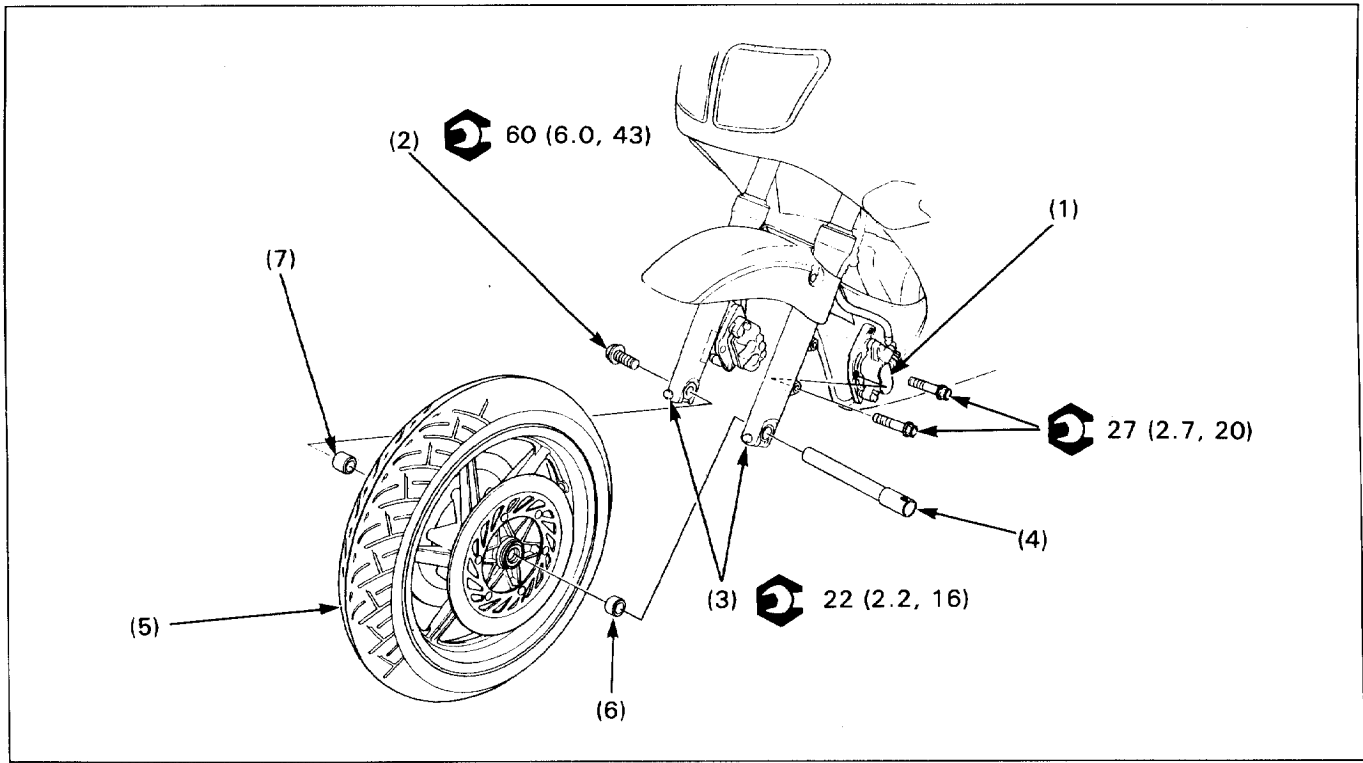

**WARNING**

- A contaminated brake disc or pad reduces stopping power. Discard contaminated pads and clean a contaminated disc with a high quality brake degreasing agent.
- Inhaled asbestos fibers have been found to cause respiratory disease and cancer. Never use an air hose or dry brush to clean brake assemblies. Use an OSHA-approved vacuum cleaner or alternate method approved by OSHA designed to minimize the hazard caused by airborne asbestos fibers.
- Failure to provide adequate disc to caliper holder clearance may damage the brake disc and impair braking efficiency; refer to the owner's manual for caliper holder clearance adjustment.

**CAUTION**

- Support the caliper assembly so that it does not hang on the brake hose. Do not twist the brake hose.

**NOTE**

- Do not depress the brake lever when the caliper is removed, or it will be difficult to refit the disc between the brake pads.

**Requisite Service**

- Raise the front wheel off the ground by placing a jack or other support under the engine.

Procedure	Q'ty	Remarks
<b>Removal Order</b>		• Installation is in the reverse order of removal.
(1) Left brake caliper assembly	1	After removing, hang it on a piece of wire from the frame.
(2) Axle bolt	1	
(3) Axle pinch bolt	2	Only loosen the bolts.
(4) Axle shaft	1	
(5) Front wheel assembly	1	When installing, be careful not to damage the brake pads with the disc.
(6) Left side collar	1	Shorter one
(7) Right side collar	1	Longer one



# Front Wheel Disassembly/Assembly

'90-'93:

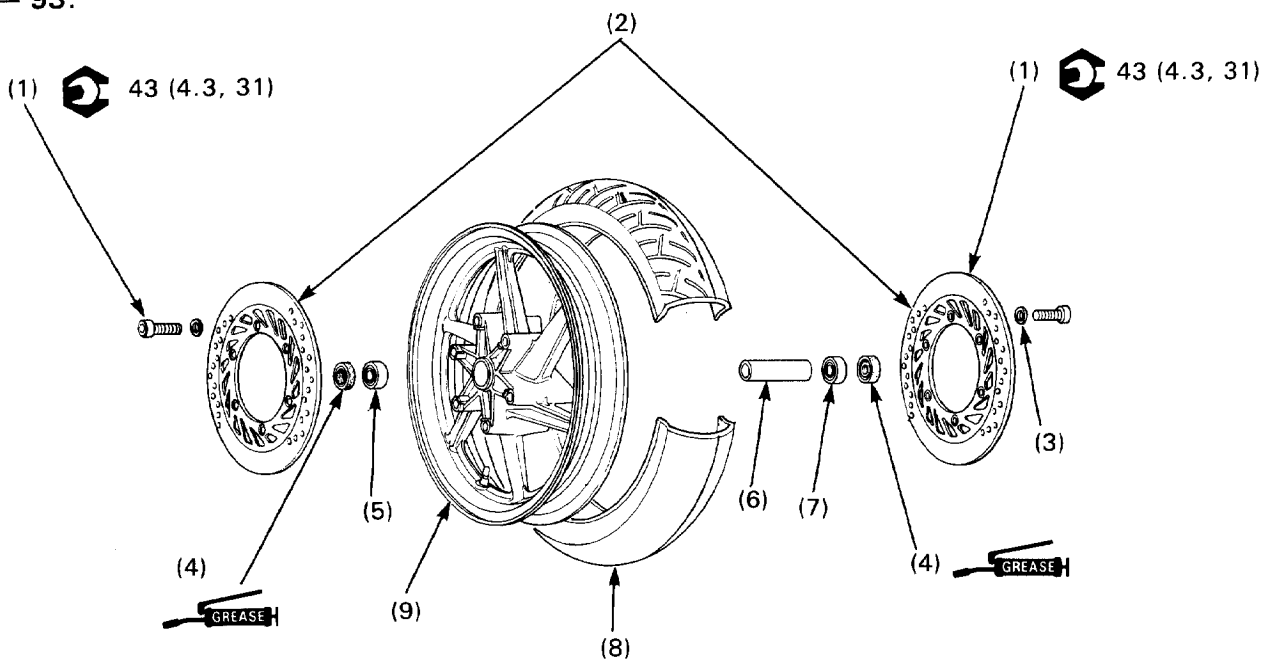

**WARNING**

• A contaminated brake disc or pad reduces stopping power. Discard contaminated pads and clean a contaminated disc with a high quality brake degreasing agent.

**NOTE**

- Always replace wheel bearings as a set.
- For wheel bearing replacement, refer to the section 1 of the Common Service Manual.

**Requisite Service**

- Front wheel removal/installation (page 12-4)

Procedure	Q'ty	Remarks
<b>Disassembly Order</b>		
(1) Brake disc bolt	12	• Assembly is in the reverse order of disassembly. Wipe off all the grease on the bolt surface.
(2) Brake disc	2	• Install with the stamped side outward. • Each brake disc is stamped with the identification mark "R" (for right side) or "L" (for left side). Install the brake discs correctly.
(3) Brake disc shim	12	
(4) Dust seal	2	Apply grease to the dust seal lips and install them with the lips facing inside.
(5) Left wheel bearing (6004 UU)	1	
(6) Distance collar	1	
(7) Right wheel bearing (6004 UU)	1	<b>NOTE:</b> • Drive in the right side bearing first, then the left side bearing.
(8) Tire	1	
(9) Front wheel	1	

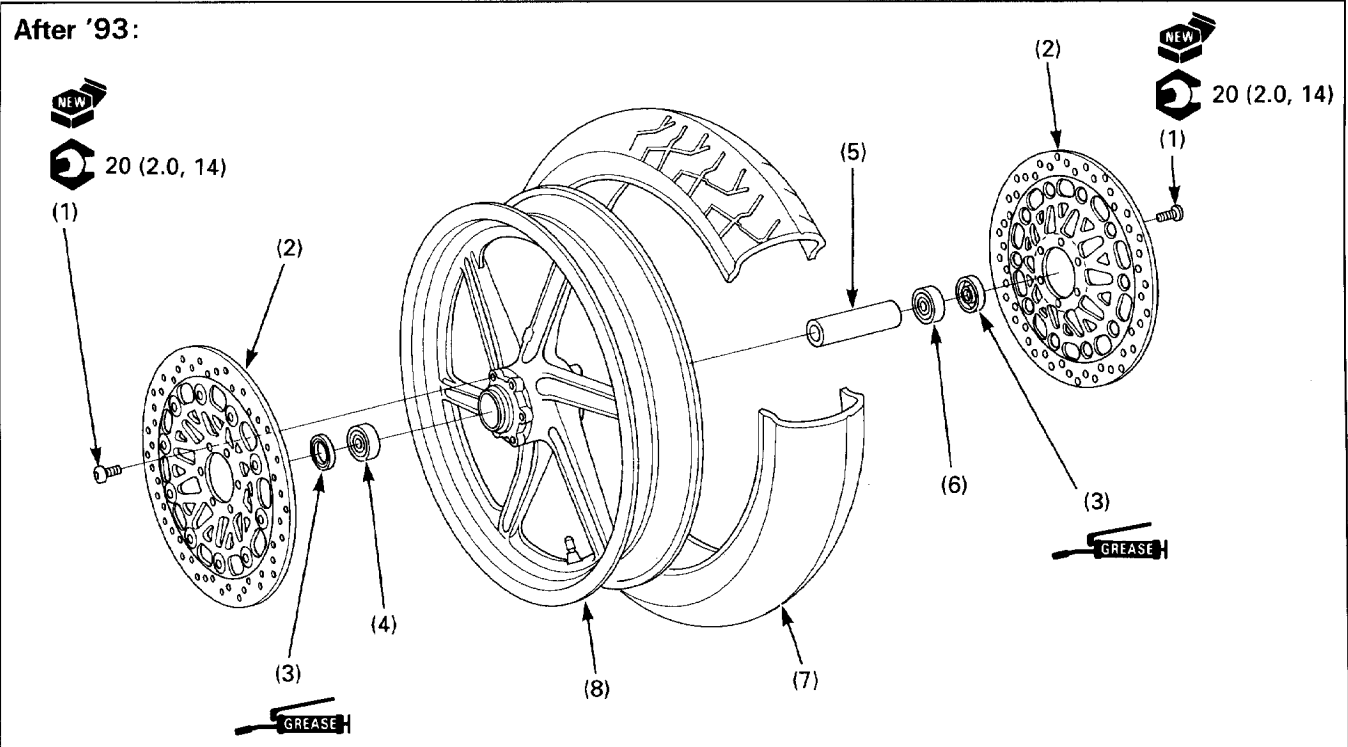

**WARNING**

- A contaminated brake disc or pad reduces stopping power. Discard contaminated pads and clean a contaminated disc with a high quality brake degreasing agent.

**NOTE**

- Always replace wheel bearings as a set.
- For wheel bearing replacement, refer to the section 1 of the Common Service Manual.

**Requisite Service**

- Front wheel removal/installation (page 12-4)

Procedure		Q'ty	Remarks
<b>Disassembly Order</b>			Assembly is in the reverse order of disassembly.
(1)	Brake disc bolt	12	NOTE • Install in the original position with the arrow mark facing out and pointing in the rotating direction.
(2)	Brake disc	2	
(3)	Dust seal	2	Apply grease to the dust seal lips and install them with the lip side facing inside.
(4)	Left wheel bearing (6004 UU)	1	Drive in a new right bearing first.
(5)	Distance collar	1	
(6)	Right wheel bearing (6004 UU)	1	
(7)	Tire	1	
(8)	Front wheel	1	

# Fork Removal/Installation

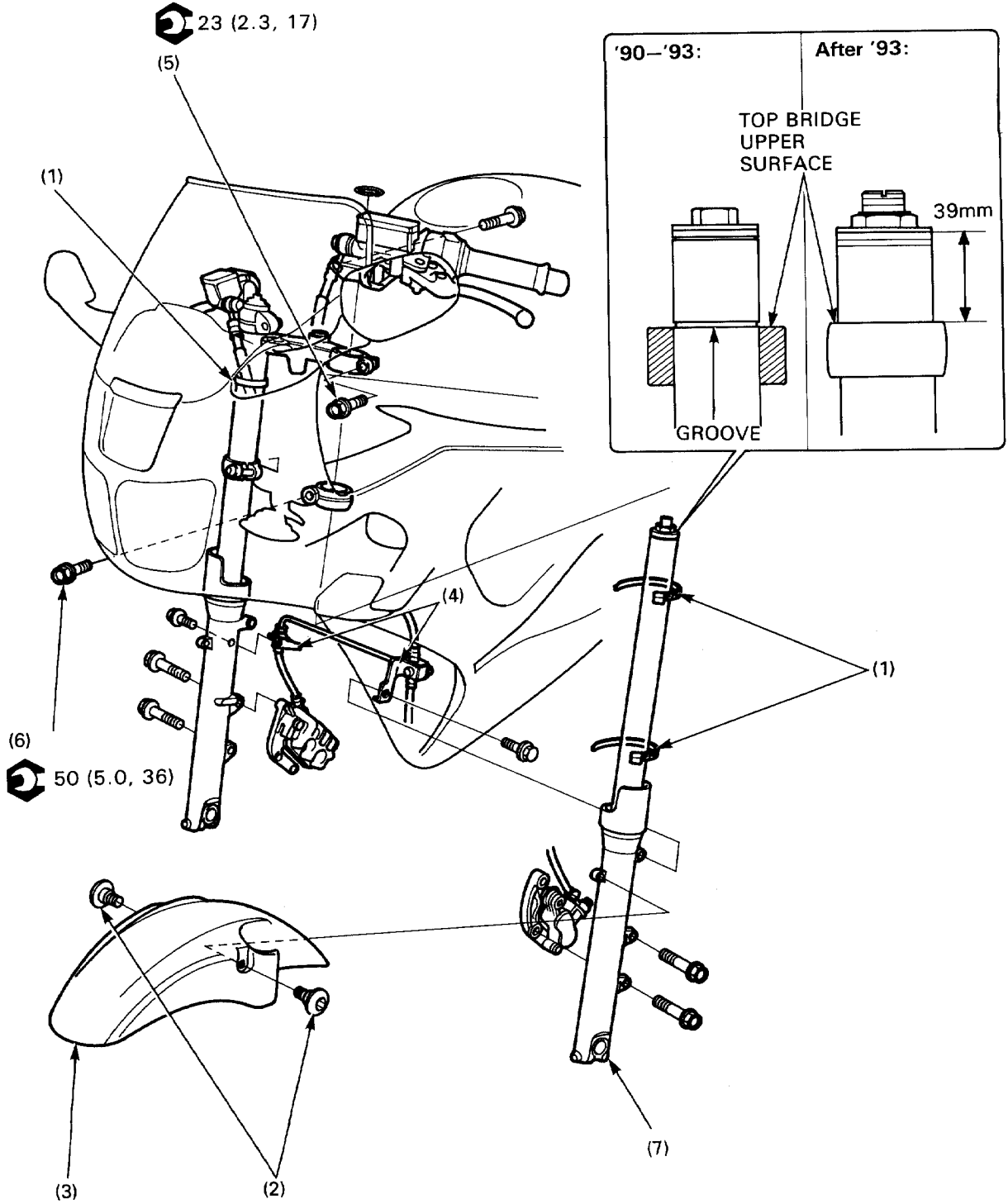

NOTE

- If the fork legs will be disassembled, loosen the fork cap after loosening the top bridge pinch bolt, but do not remove it yet.
- After assembling the fork, tighten the fork cap before tightening the top bridge pinch bolt.

Requisite Service

- Handlebar removal/installation (page 12-2 and 12-3)
- Front wheel removal/installation (page 12-4)

Procedure		Q'ty	Remarks
	<b>Removal Order</b>		Installation is in the reverse order of removal.
(1)	Wire band	3	
(2)	Front fender bolt	2	
(3)	Front fender	1	
(4)	Brake hose clamp	2	
(5)	Top bridge pinch bolt	2	Only loosen. NOTE: • Be careful not to drop the fork leg when loosening the pinch bolt.
(6)	Bottom bridge pinch bolt	2	
(7)	Fork leg	2	NOTE: '90-'93: • At installation, align the fork grooves with the top bridge upper surfaces. After '93: • At installation, allow a distance of 39 mm (1.5 in) between the fork end and the upper surface of the top bridge.

# Fork Disassembly

'90-'91:

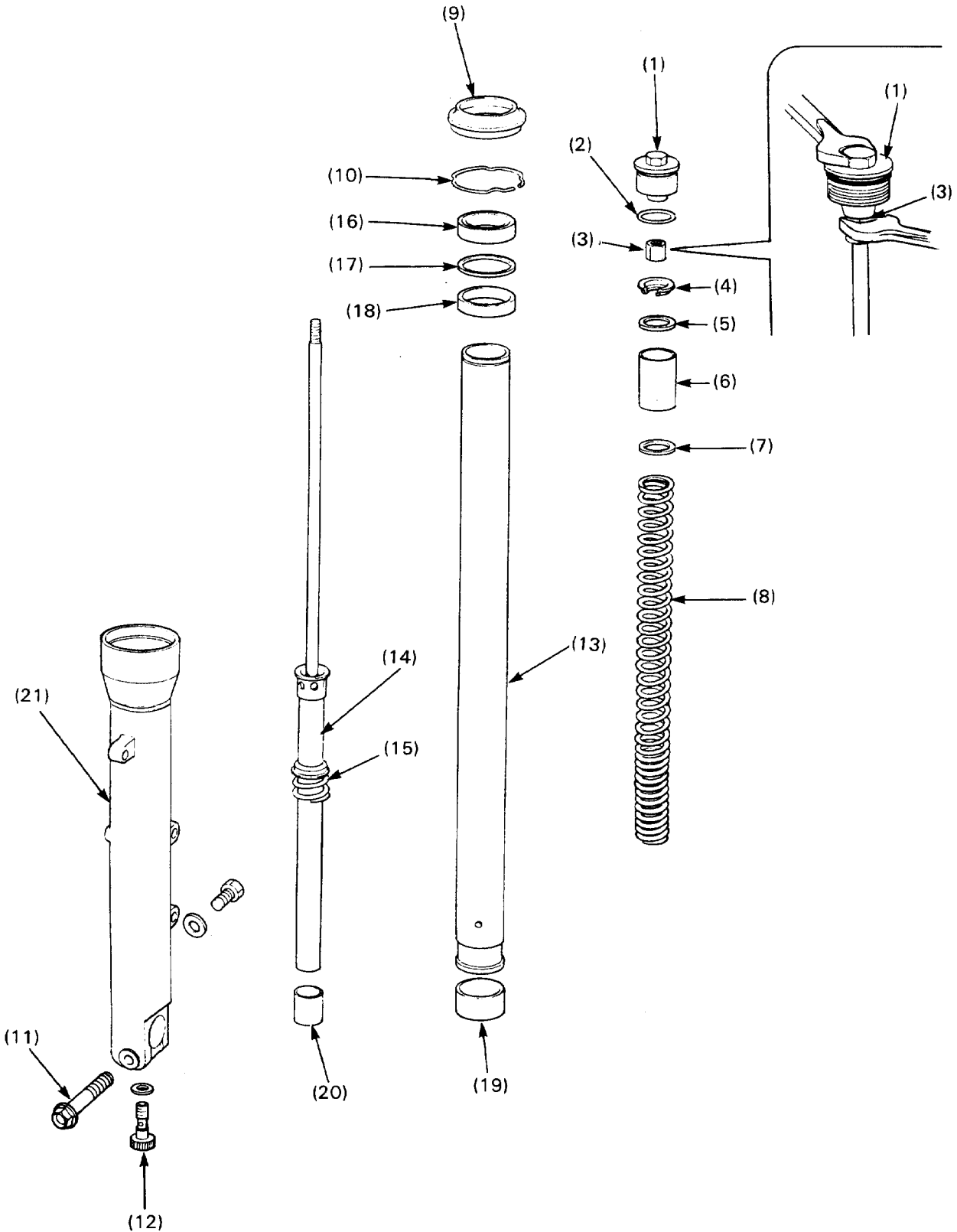

## Requisite Service

- Fork removal (page 12-8)

	Procedure	Q'ty	Remarks
(1)	Fork cap	1	<p><b>▲ WARNING</b></p> <ul style="list-style-type: none"> <li>• The fork cap is under high pressure. Use care when loosening the cap.</li> </ul> <p>Remove the fork cap while holding the lock nut as shown.</p>
(2)	O-ring	1	
(3)	Lock nut	1	
(4)	Retainer	1	
(5)	Seat washer	1	
(6)	Spacer	1	
(7)	Spring seat	1	
(8)	Fork spring	1	After removing, drain the remaining fork oil completely.
(9)	Dust seal	1	When removing them, do not damage the fork tube.
(10)	Stopper ring	1	
(11)	Axle pinch bolt	1	
(12)	Fork socket bolt	1	<p><b>NOTE:</b></p> <ul style="list-style-type: none"> <li>• Temporarily install the spring and fork cap if difficulty is encountered when removing the socket bolt.</li> </ul>
(13)	Fork tube	1	
(14)	Fork cylinder assembly	1	
(15)	Rebound spring	1	
(16)	Oil seal	1	
(17)	Back up ring	1	
(18)	Slider bushing	1	
(19)	Fork tube bushing	1	<p><b>NOTE:</b></p> <ul style="list-style-type: none"> <li>• Do not remove it unless it is necessary to replace.</li> </ul>
(20)	Oil lock piece	1	
(21)	Fork slider	1	

After '91:

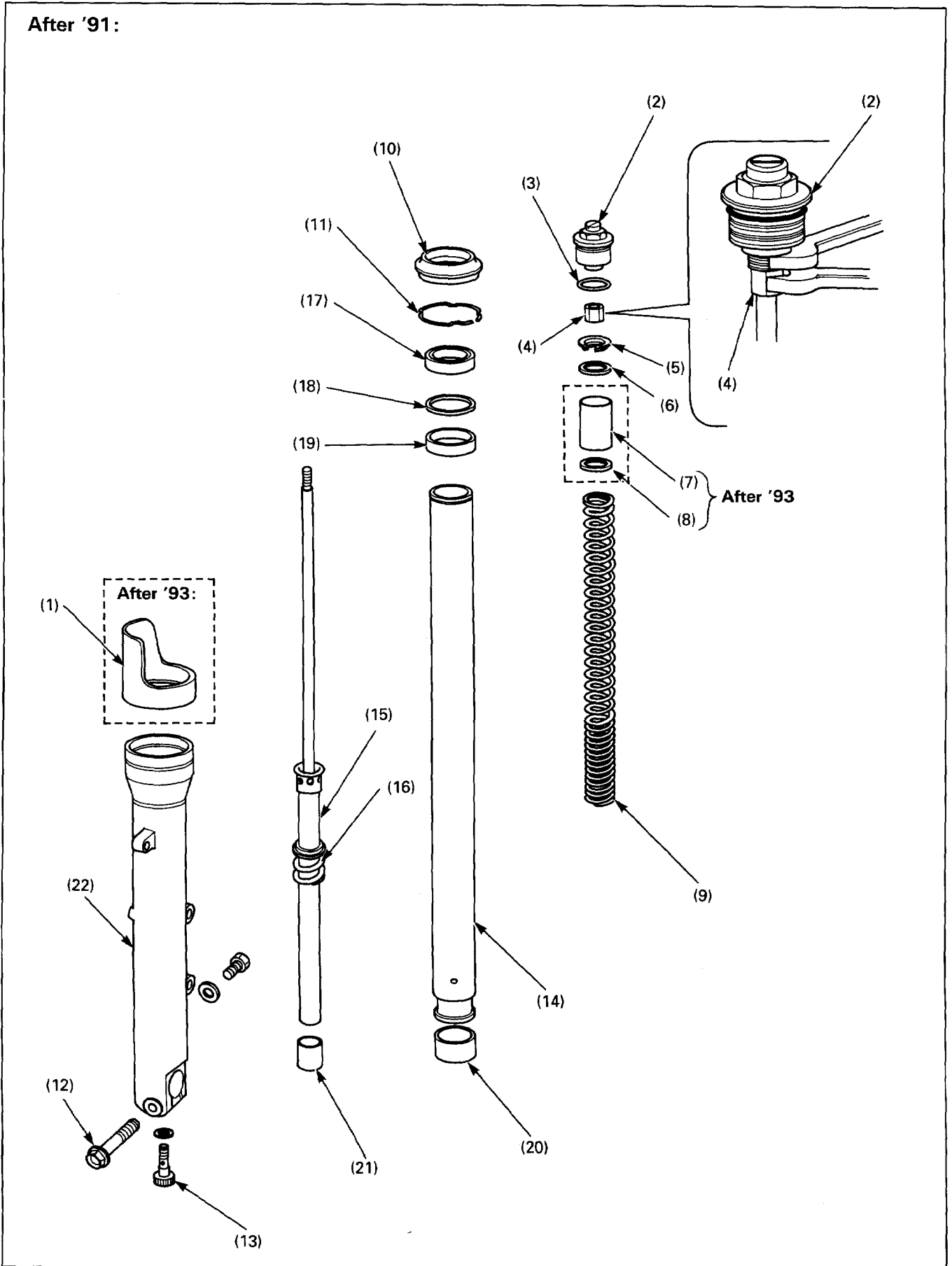

**Requisite Service**

- Fork removal (page 12-8)

Procedure		Q'ty	Remarks
(1)	<b>Disassembly Order</b> Fork tube protector (After '93)	1	<p>NOTE:</p> <ul style="list-style-type: none"> <li>• Do not remove unless necessary.</li> </ul> <p><b>▲ WARNING</b></p> <ul style="list-style-type: none"> <li>• The fork cap bolt is under high pressur. Use care when loosening the bolt.</li> </ul> <p>Remove the fork cap bolt holding the lock nut as shown.</p> <p>After removing, drain the remaining fork oil completely. When removing them, do not damage the fork tube.</p>
(2)	Fork cap bolt	1	
(3)	O-ring	1	
(4)	Lock nut	1	
(5)	Retainer	1	
(6)	Seat washer	1	
(7)	Spacer (After '93)	1	
(8)	Spring seat (After '93)	1	
(9)	Fork spring	1	
(10)	Dust seal	1	
(11)	Stopper ring	1	
(12)	Fork pinch bolt	1	
(13)	Fork socket bolt	1	
(14)	Fork tube	1	<p>NOTE:</p> <ul style="list-style-type: none"> <li>• Temporarily install the spring and fork cap bolt if difficulty is encountered when removing the socket bolt.</li> </ul>
(15)	Fork cylinder assembly	1	
(16)	Rebound spring	1	
(17)	Oil seal	1	
(18)	Back up ring	1	
(19)	Slider bushing	1	
(20)	Fork tube bushing	1	
(21)	Oil lock piece	1	<p>NOTE:</p> <ul style="list-style-type: none"> <li>• Do not remove it unless it is necessary to replace.</li> </ul>
(22)	Fork slider	1	

# Fork Assembly

'90-'91:

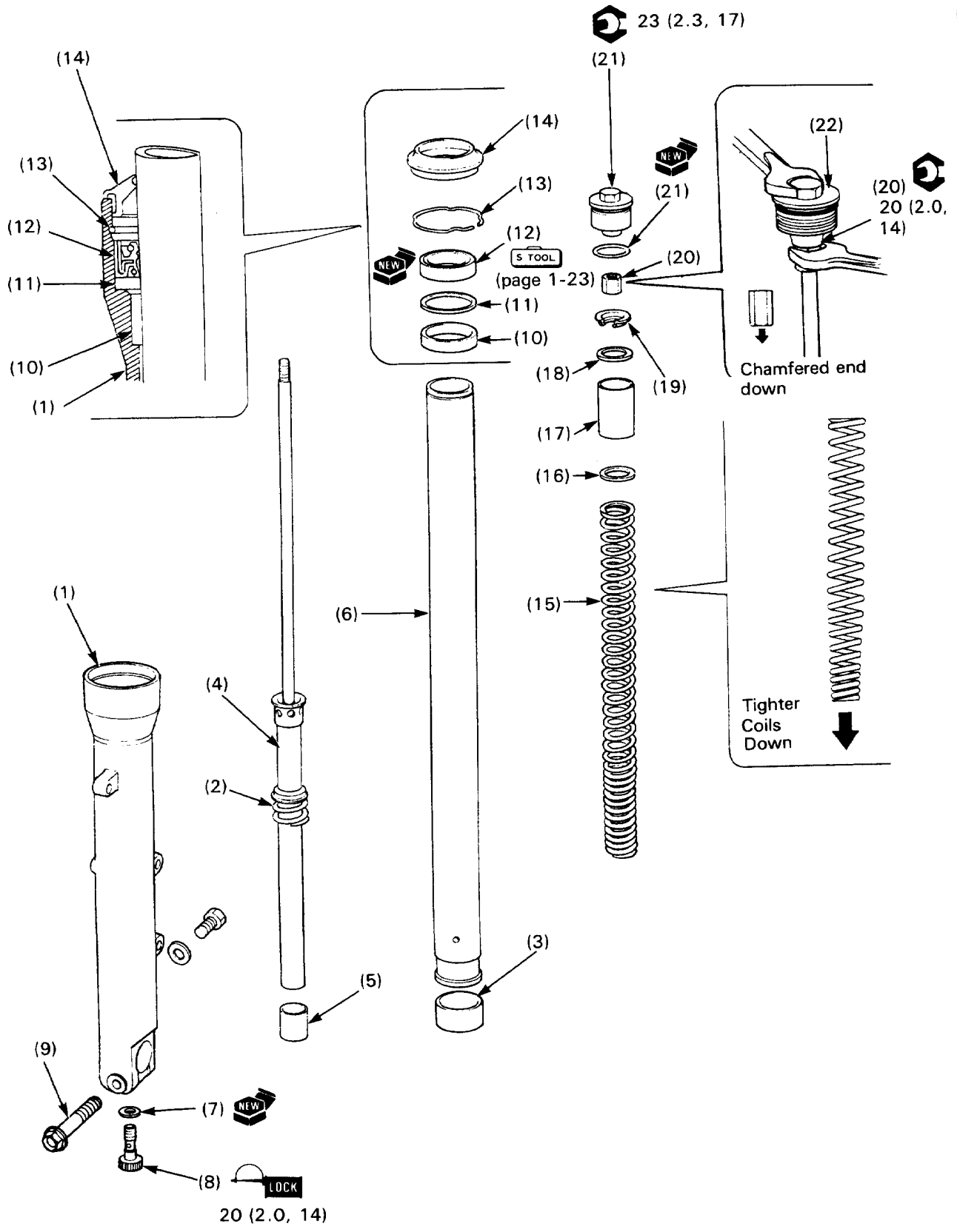

## NOTE

- Clean all disassembled parts.

**Requisite Service**

- Fork installation (page 12-8)

Procedure		Q'ty	Remarks
(1)	Fork slider	1	
(2)	Rebound spring	1	Install on the fork cylinder assembly with the tighter wound coil pitch facing cylinder flange.
(3)	Fork tube bushing	1	Replace with a new one if it was removed from the piston.
(4)	Fork cylinder assembly	1	Insert into the fork tube (6).
(5)	Oil lock piece	1	Install onto the fork cylinder assembly.
(6)	Fork tube	1	Insert into the fork slider (1) with the fork cylinder assembly (4), being careful not to drop the oil lock piece (5).
(7)	Sealing washer	1	
(8)	Fork socket bolt	1	NOTE: • Temporarily install the fork spring and fork cap so that the piston is held in place when the socket bolt is tightened.
(9)	Axle pinch bolt	1	
(10)	Slider bushing	1	
(11)	Back up ring	1	
(12)	Oil seal	1	NOTE: • Wrap vinyl tape around the fork tube top end to avoid damaging the oil seal during the oil seal installation. • Drive in the oil seal, using the fork seal driver (07947-KA50100) and attachment (07947-KFO0100) until the oil seal surface is lower than the groove for the stopper ring.
(13)	Stopper ring	1	Install into the slider groove securely.
(14)	Dust seal	1	NOTE: • After installing it, compress the fork tube fully and pour the specified amount of fork fluid (page 1-11) into the fork tube. Measure the fork oil level from the top of the tube after stroking the tube and piston rod several times.
(15)	Fork spring	1	NOTE: • Wipe oil off the spring thoroughly using a clean lint free cloth and install with tightly wound coil end facing down.
(16)	Spring seat	1	
(17)	Spacer	1	
(18)	Seat washer	1	
(19)	Retainer	1	
(20)	Lock nut	1	Thread completely by hand with the chamfered end facing down.
(21)	O-ring	1	
(22)	Fork cap	1	Tighten the lock nut holding the fork cap as shown, then tighten the fork cap slightly, being careful not to cross-thread the cap. After installing the fork into the steering stem, torque the cap.

After '91:

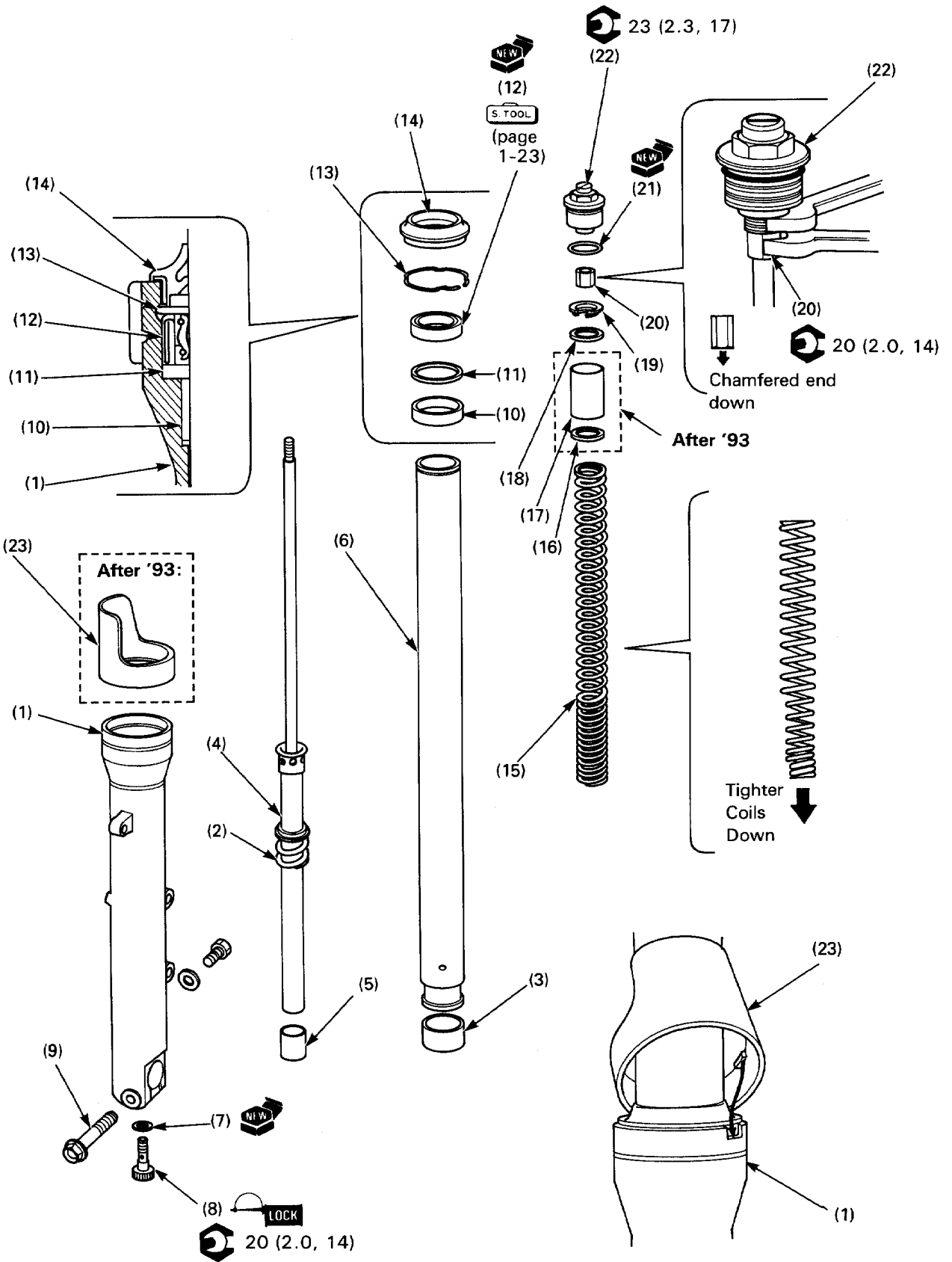

## NOTE

- Clean all disassembled parts.

**Requisite Service**

- Fork installation (page 11-8)

Procedure	Q'ty	Remarks
(1) Fork slider	1	
(2) Rebound spring	1	Install the fork cylinder assembly with the tighter wound coil pitch facing cylinder frange.
(3) Fork tube bushing	1	Replace with a new one if it was removed from the piston.
(4) Fork cylinder assembly	1	Insert into the fork tube (6).
(5) Oil lock piece	1	Install onto the fork cylinder assembly.
(6) Fork tube	1	Insert into the fork slider (1) with the fork cylinder assembly (4), being careful not to drop the oil lock piece (5).
(7) Sealing washer	1	
(8) Fork socket bolt	1	NOTE: • Temporarily install the fork spring and fork cap bolt so that the piston is held in place when the socket bolt is tightened.
(9) Fork pinch bolt	1	
(10) Slider bushing	1	
(11) Back up ring	1	
(12) Oil seal	1	NOTE: • Wrap vinyl tape around the fork tube top end to avoid damaging the oil seal during the oil seal installation. • Drive in the oil seal, using the fork seal driver (07947-KA50100) and attachment (07947-KF00100) until the oil seal surface is lower than the groove for the stopper ring.
(13) Stopper ring	1	Install into the slider groove securely.
(14) Dust seal	1	NOTE: • After installing it, compress the fork tube fully and pour the specified amount of fork fluid (page 1-12) into the fork tube. Measure the fork oil level from the top of the tube after stroking the tube and piston rod several times.
(15) Fork spring	1	NOTE: • Wipe oil off the spring thoroughly using a clean lint free cloth and install with tightly wound coil end facing down.
(16) Spring seat (After '93)	1	
(17) Spacer (After '93)	1	
(18) Seat washer	1	
(19) Retainer	1	
(20) Lock nut	1	Thread completely with hand with the chamfered end facing down.
(21) O-ring	1	
(22) Fork cap bolt	1	Tighten the lock nut holding the fork cap bolt as shown, then tighten the fork cap bolt slightly, being careful not to cross-thread the bolt; after installing the fork into the steering stem, torque the bolt.
(23) Fork tube protector (After '93)	1	Align the lug with the groove in the fork slider. NOTE • For easy installation, immerse in hot water (50–60°C/ 122–140°F).

# Steering Stem Removal/Installation

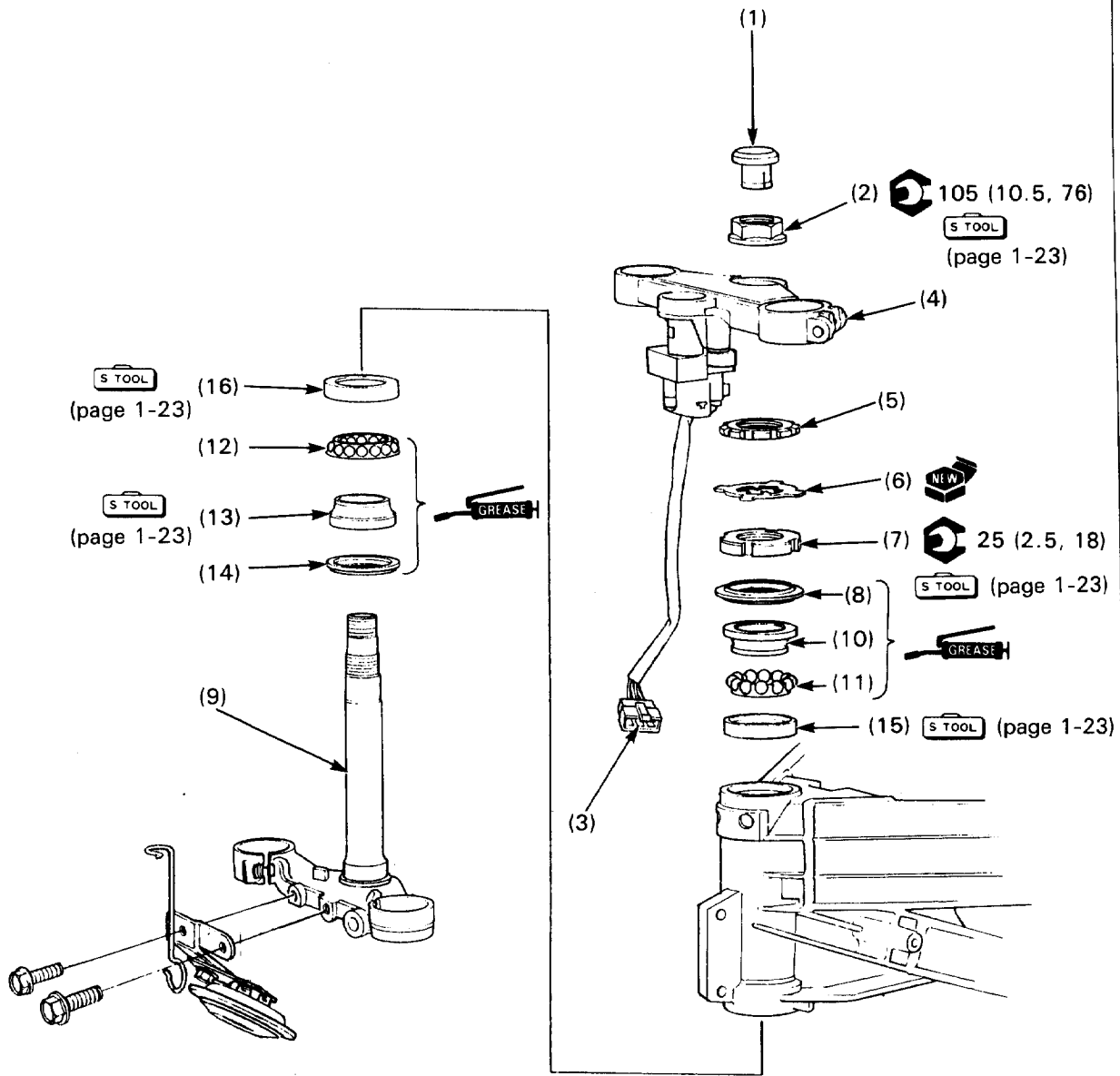

NOTE

- Bearings should always be replaced as a set-inner and outer races.
- Remove the fork, after loosening the steering stem nut.
- Check the steering head bearing preload (page 1-11) after torquing the stem nut.

**Requisite Service**

- Front wheel removal/installation (page 12-4)
- Fork removal/installation (page 12-8)

Procedure	Q'ty	Remarks
<b>Removal Order</b>		
(1) Steering stem nut cap	1	After removing, remove the fork.  NOTE: • Remove, after straightening the lock washer tabs.  Replace if they were removed (refer to Common Service Manual). • Use ball race remover set (except Bearing remover B, 55mm: 07946-KM90500) for upper outer race removal. • Use ball race remover set (except Bearing remover A, 47mm: 07946-KM90401) for lower outer race removal.
(2) Steering stem nut	1	
(3) Ignition switch connector	1	
(4) Top bridge	1	
(5) Lock nut	1	
(6) Lock washer	1	
(7) Steering head bearing adjustment nut	1	
(8) Dust seal	1	
(9) Steering stem	1	
(10) Upper inner race	1	
(11) Upper bearing	1	
(12) Lower bearing	1	
(13) Lower inner race	1	
(14) Dust seal	1	
(15) Upper outer race	1	
(16) Lower outer race	1	
<b>Installation Order</b>		
(16) Lower outer race	1	Replace as a set, if necessary (refer to Common Service Manual). • Use ball race remover set (except bearing remover A and B). • Use steering stem driver: 07946-MB00000 for lower inner race installation.  Installation: refer to section 18 of the Common Service Manual (Retainer-Type Ball Bearings).  Refer to page 1-20 for correct routing. Temporarily install fork and torque the nut.
(15) Upper outer race	1	
(14) Dust seal	1	
(13) Lower inner race	1	
(12) Lower bearing	1	
(11) Upper bearing	1	
(10) Upper inner race	1	
(9) Steering stem	1	
(8) Dust seal	1	
(7) Steering head bearing adjustment nut	1	
(6) Lock washer	1	
(5) Lock nut	1	
(4) Top bridge	1	
(3) Ignition switch connector	1	
(2) Steering stem nut	1	
(1) Steering stem nut cap	1	



# 13. Rear Wheel/Suspension

Service Information	13-1	Shock Absorber Disassembly/Assembly ('90-'93 Only)	13-10
Troubleshooting	13-1		
Rear Wheel Removal/Installation	13-2	Suspension Linkage Removal/Installation	13-14
Bearing Holder Removal/Installation	13-3	Suspension Linkage Disassembly/Assembly	13-15
Driven Flange, Bearing Holder Disassembly/Assembly	13-4	Swingarm Removal/Installation	13-20
Shock Absorber Removal/Installation	13-6	Swingarm Disassembly/Assembly	13-23

## Service Information

### ▲ WARNING

- The shock absorber contains nitrogen under high pressure. Do not allow fire or heat near the shock absorber.
- Before disposal of the shock absorber, release the nitrogen (Step: section 19 of the Common Service Manual; Drilling point: page 1-13)
- A contaminated brake disc or pad reduces stopping power. Discard contaminated pads and clean a contaminated disc with a high quality brake degreasing agent.
- Inhaled asbestos fibers have been found to cause respiratory disease and cancer. Never use an air hose or dry brush to clean brake assemblies. Use an OSHA-approved vacuum cleaner or alternate method approved by OSHA designed to minimize the hazard caused by airborne asbestos fibers.
- Riding on damaged rims impairs safe operation of the vehicle.

- Refer to the section 14 for brake system information.
- Tubeless tire removal, repair, and remounting procedures are covered in the section 16 of the Common Service Manual.

13

## Troubleshooting

### Rear wheel wobbling

- Bent rim
- Worn rear wheel bearings
- Faulty tire
- Unbalanced tire and wheel
- Low tire pressure
- Faulty swingarm pivot bearing(s)

### Wheel turns hard

- Faulty holder bearing(s)
- Brake drag
- Bent rear axle

### Soft suspension

- Weak spring
- Incorrect suspension adjustment
- Oil leakage from damper unit
- Low tire pressure

### Hard suspension

- Damaged shock absorber upper or lower bearings
- Incorrect suspension adjustment
- Bent damper rod
- Damaged swingarm pivot bearing
- High tire pressure

### Rear suspension noisy

- Loose fasteners

# Rear Wheel Removal/Installation

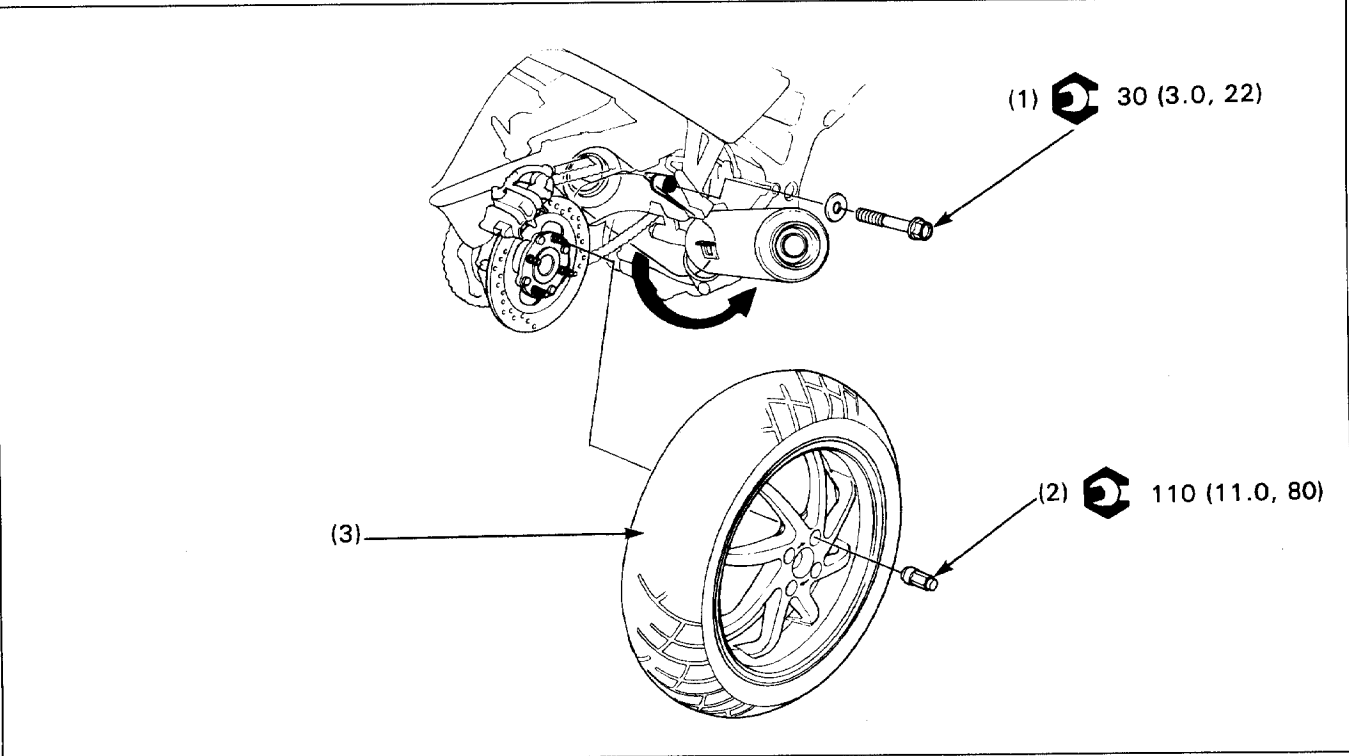

**⚠ WARNING**

- A contaminated brake disc or pad reduces stopping power. Discard contaminated pads and clean a contaminated disc with a high quality brake degreasing agent.
- Inhaled asbestos fibers have been found to cause respiratory disease and cancer. Never use an air hose or dry brush to clean brake assemblies. Use an OSHA-approved vacuum cleaner or alternate method approved by OSHA designed to minimize the hazard caused by airborne asbestos fibers.

**NOTE**

- Support the motorcycle by placing a support block under the exhaust system or with the optional center stand.
- Do not depress the brake pedal when the caliper is removed, or it will be difficult to refit the disc between the brake pads.
- Support the removed caliper with a piece of wire so that it does not hang from the brake hose.
- Adjust the drive chain free play after installing the wheel.

Procedure	Q'ty	Remarks
<b>Removal Order</b>		• Installation is in the reverse order of removal.
(1) Muffler mounting bolt	1	After removing, move the muffler away from the rear wheel to the direction shown by arrow.
(2) Rear wheel nut	4	Loosen while applying rear brake.
(3) Rear wheel	1	

## Bearing Holder Removal/Installation

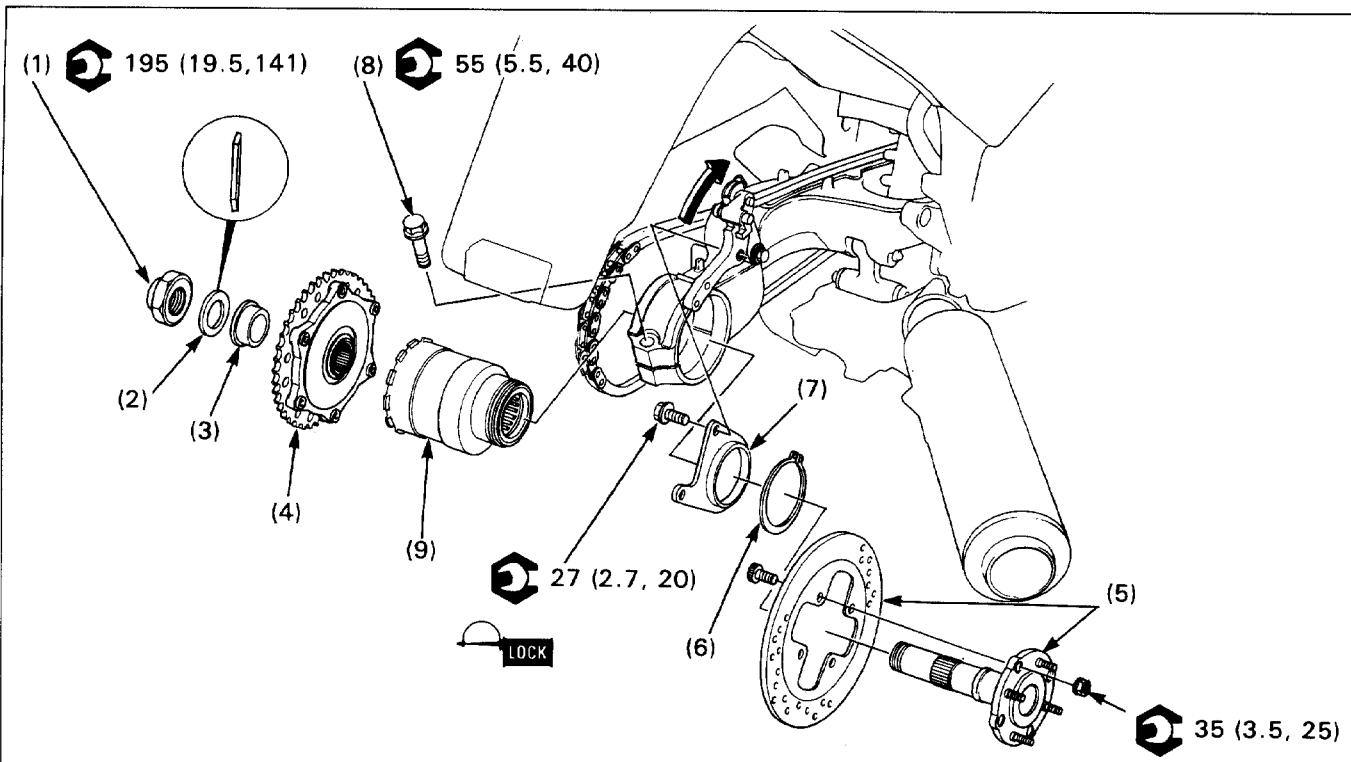

### WARNING

- A contaminated brake disc or pad reduces stopping power. Discard contaminated pads and clean a contaminated disc with a high quality brake degreasing agent.

### NOTE

- Do not depress the brake pedal when the caliper is removed, or it will be difficult to refit the disc between the brake pads.

### Requisite Service

- Rear wheel removal/installation (page 13-2)

Procedure	Q'ty	Remarks
<b>Disassembly Order</b>		• Assembly is in the reverse order of disassembly.
(1) Rear axle nut	1	Unstake the nut before removing.
(2) Spring washer	1	Install in the direction as shown.
(3) Flange collar	1	
(4) Driven sprocket	1	
(5) Rear axle/brake disc	1/1	Before removing, detach the caliper from the disc by pivoting upward as shown.
(6) Snap ring	1	Install chamfered side facing in.
(7) Caliper stay	1	
(8) Bearing holder pinch bolt	1	Only loosen, not necessary to remove.
(9) Bearing holder	1	Refer to page 13-4 for disassembly/assembly.

# Driven Flange, Bearing Holder Disassembly/Assembly

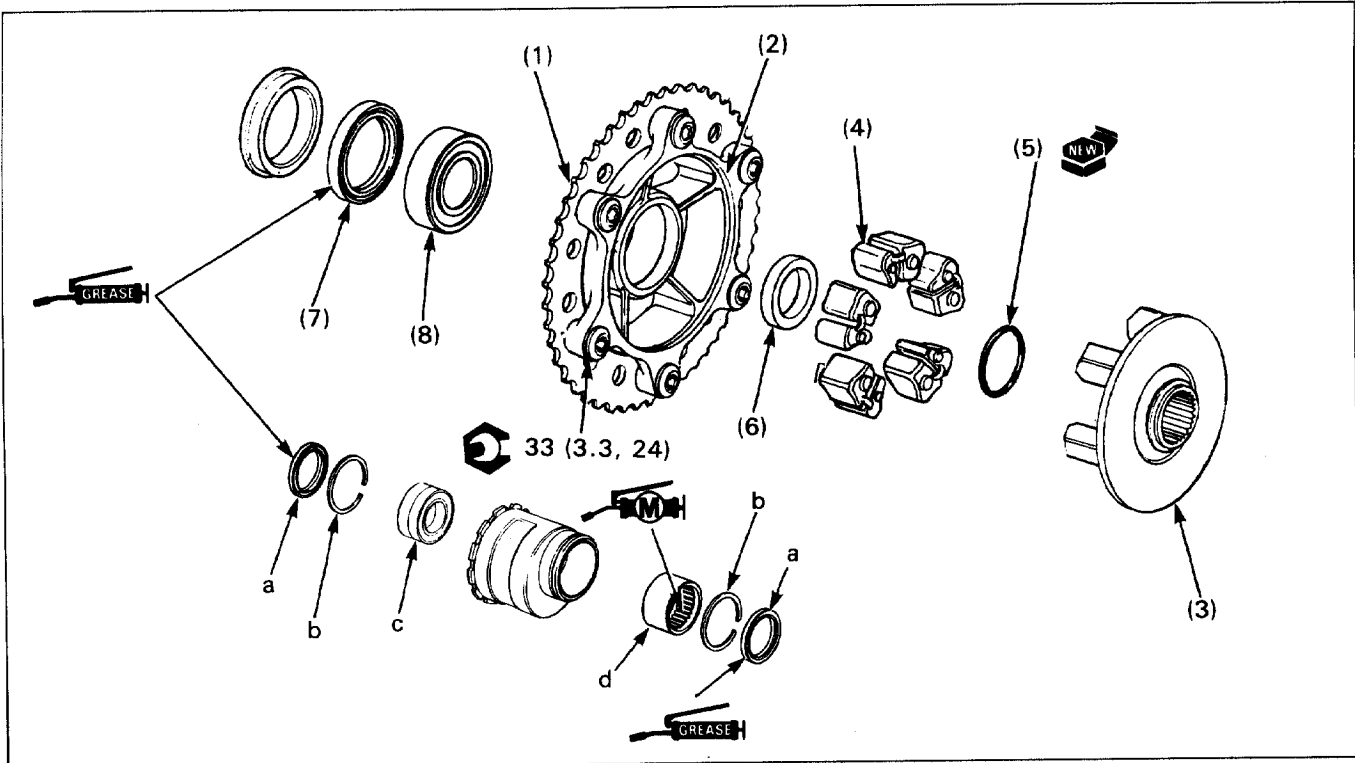

**NOTE**

- Replace the bearing holder as a set (page 13-5).
- Replace the damper rubbers as a set.

**Requisite Service**

- Bearing holder driven flange removal/installation (page 13-3)

Procedure	Q'ty	Remarks
<b>Driven Flange Disassembly</b>		• Assembly is in the reverse order of disassembly.
(1) Driven sprocket	1	
(2) Driven flange	1	
(3) Driven sprocket hub	1	
(4) Damper rubber	5	
(5) O-ring	1	NOTE: • Be careful not to cut the O-ring when assembling the driven flange.
(6) Distance collar	1	
(7) Dust seal	1	NOTE: • If difficulty is encountered when removing, push out with the flange bearing using a hydraulic press.
(8) Driven flange bearing	1	
<b>Bearing Holder Disassembly</b>		• Assembly is in the reverse order of disassembly; see page 13-5.
(a) Dust seal	2	
(b) Retainer ring	2	
(c) Left holder bearing	1	
(e) Right holder bearing	1	

### Driven Flange Bearing Replacement

Push the bearing and dust seal out of the driven flange using a hydraulic press.



**Driver**  
**Attachment, 42×47mm**  
**Pilot, 35mm**

**07749-0010000**  
**07746-0010300**  
**07746-0040800**

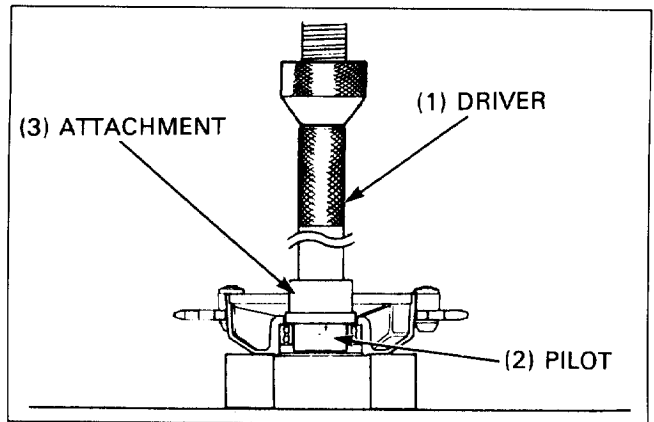

Press a new bearing into the driven flange.



**Driver**  
**Attachment, 52×55mm**  
**Pilot, 35mm**

**07749-0010000**  
**07746-0010400**  
**07746-0040800**

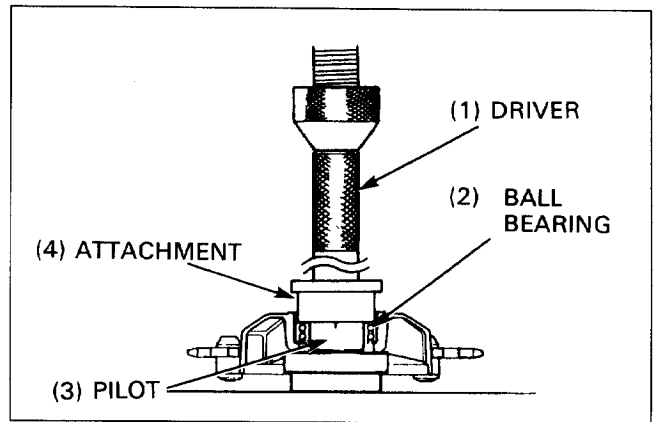

### Axle Needle Bearing Replacement

Push the needle bearing out of the bearing holder using hydraulic press.



**Driver**  
**Attachment, 42×47mm**  
**Pilot, 40mm**

**07749-0010000**  
**07746-0010300**  
**07746-0040900**

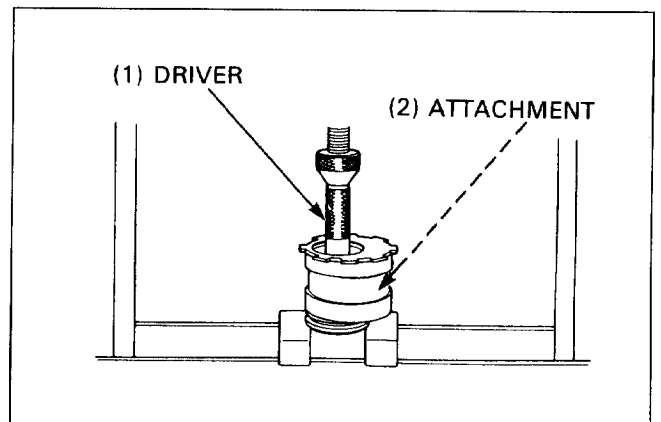

Fill a new needle bearing with grease and press it into the bearing holder using a hydraulic press.



**Driver**  
**Attachment, 62×68mm**

**07749-0010000**  
**07746-0010500**

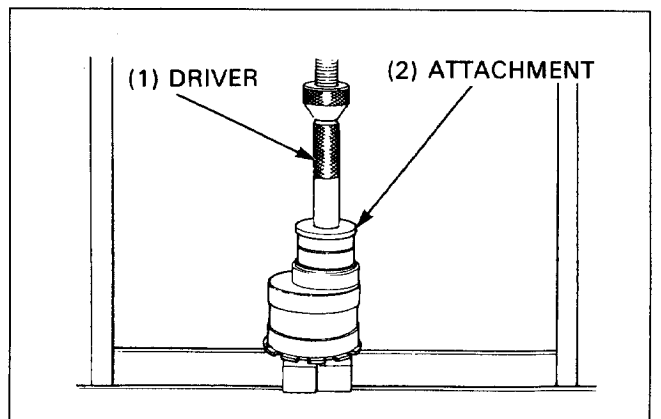

# Shock Absorber Removal/Installation

'90-'93:

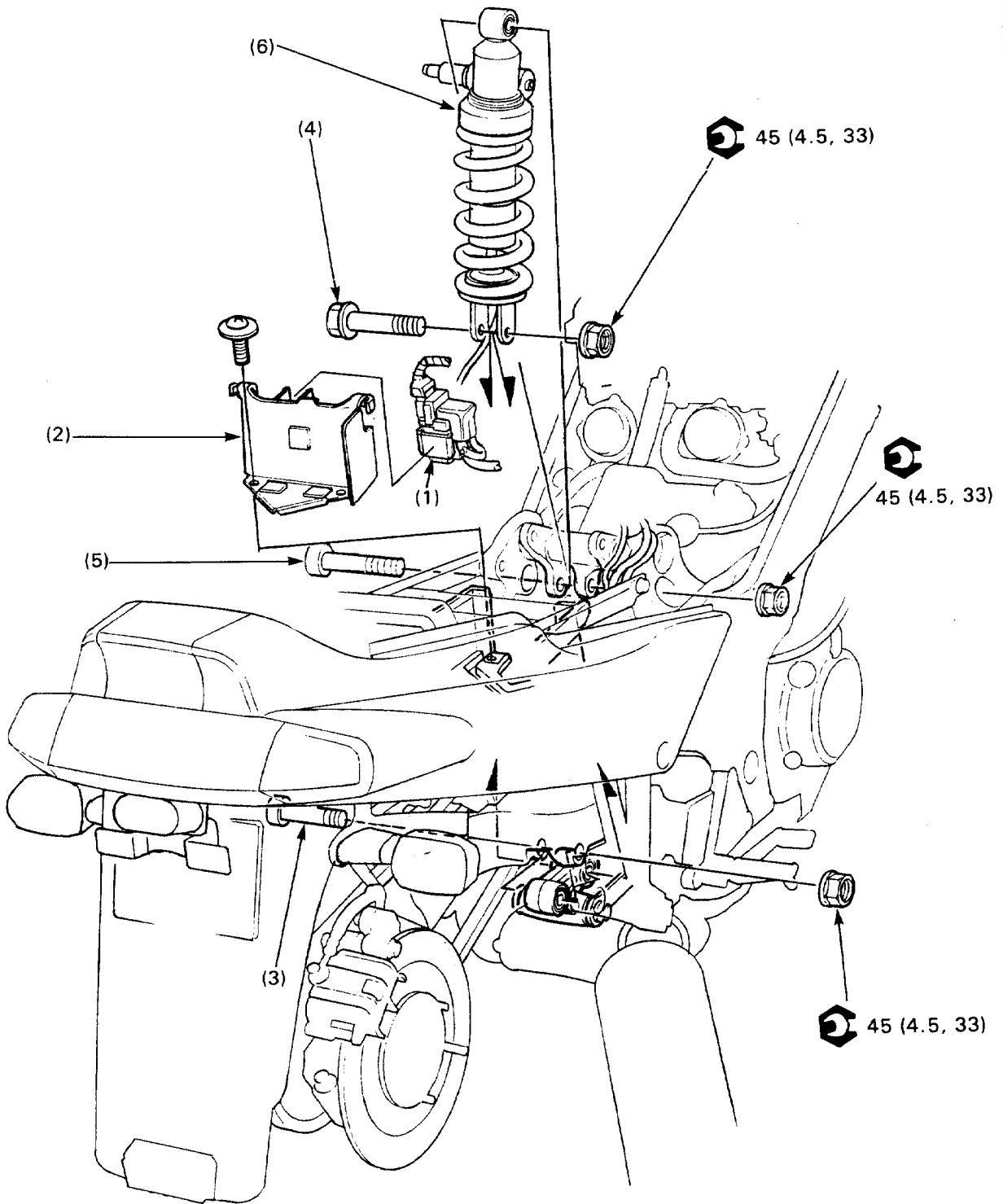

## NOTE

- Support the motorcycle by placing a support block under the exhaust system or with the optional center stand.
- Before removing the shock absorber from the frame for disassembly, note the position for reassembly and turn the spring preload adjuster counterclockwise fully (for lightest loads).

**Requisite Service**

- Fuel tank removal/installation (page 2-22)
- Rear wheel removal/installation (page 13-2)

Procedure		Q'ty	Remarks
<b>Removal Order</b>			• Installation is in the reverse order of removal.
(1)	Starter relay switch	1	
(2)	Battery case plate	1	
(3)	Connecting rod-to-frame bolt	1	At installation, install them from the left side.
(4)	Shock absorber mounting bolt (lower)	1	
(5)	Shock absorber mounting bolt (upper)	1	
(6)	Shock absorber assembly	1	<b>NOTE:</b> <ul style="list-style-type: none"> <li>• Remove it by pulling it upward out of the frame.</li> <li>• Install with the drain tube forward.</li> </ul>

After '93:

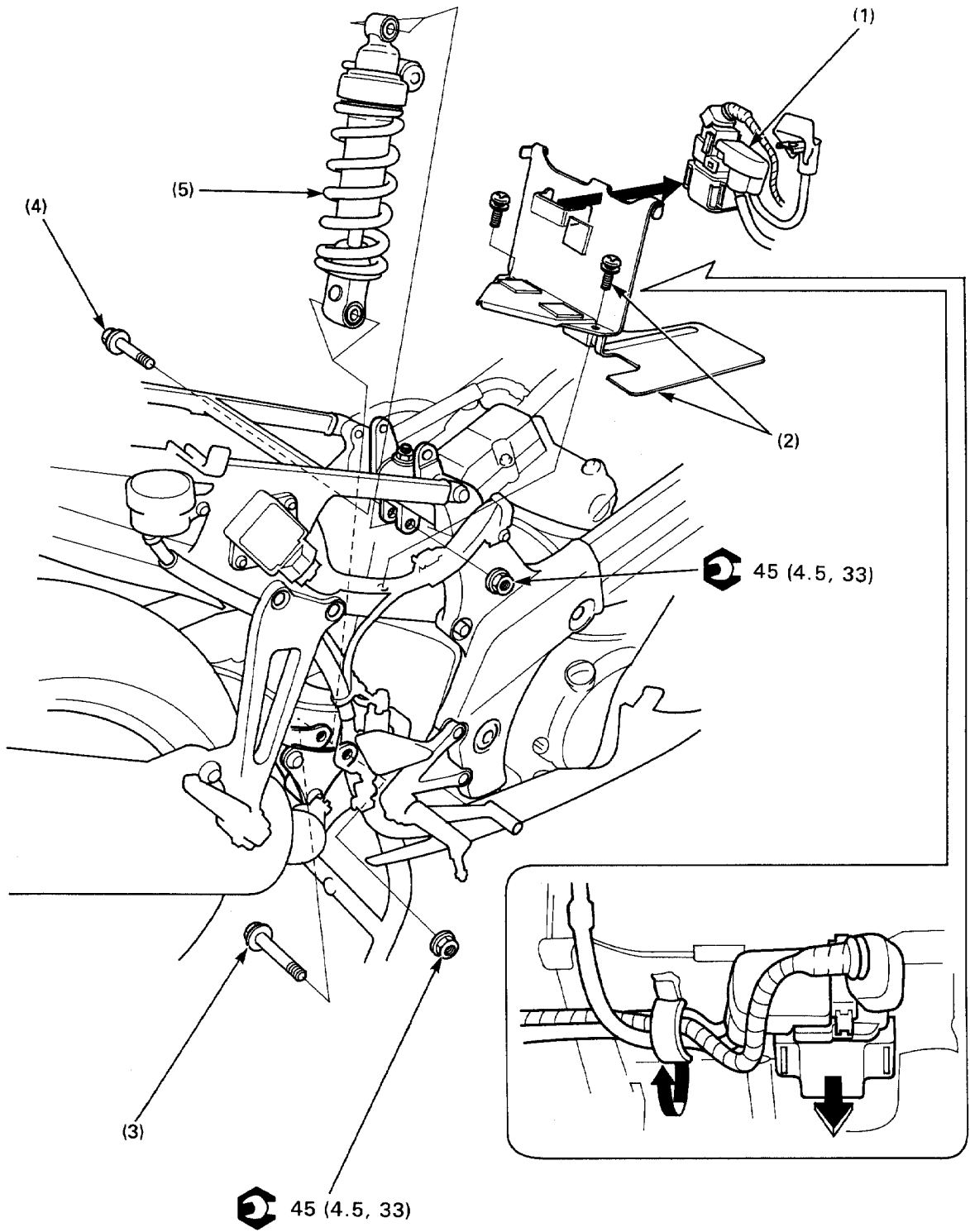

## NOTE

- Support the motorcycle on its centerstand.
- After '93 only: Do not disassemble the shock absorber.

**Requisite Service**

• Fuel tank removal/installation (page 2-22)

• Ignition coil removal/installation (page 16-8)

Procedure		Q'ty	Remarks
	<b>Removal Order</b>		Installation is in the reverse order of removal.
(1)	Starter relay switch	1	Release the wires from the clamp.
(2)	Screw/battery case plate	2/1	
(3)	Shock absorber mounting bolt (lower)	1	
(4)	Shock absorber mounting bolt (upper)	1	NOTE:
(5)	Shock absorber assembly	1	• Remove it upwards from the frame.

## Shock Absorber Disassembly/Assembly ('90-'93 Only)

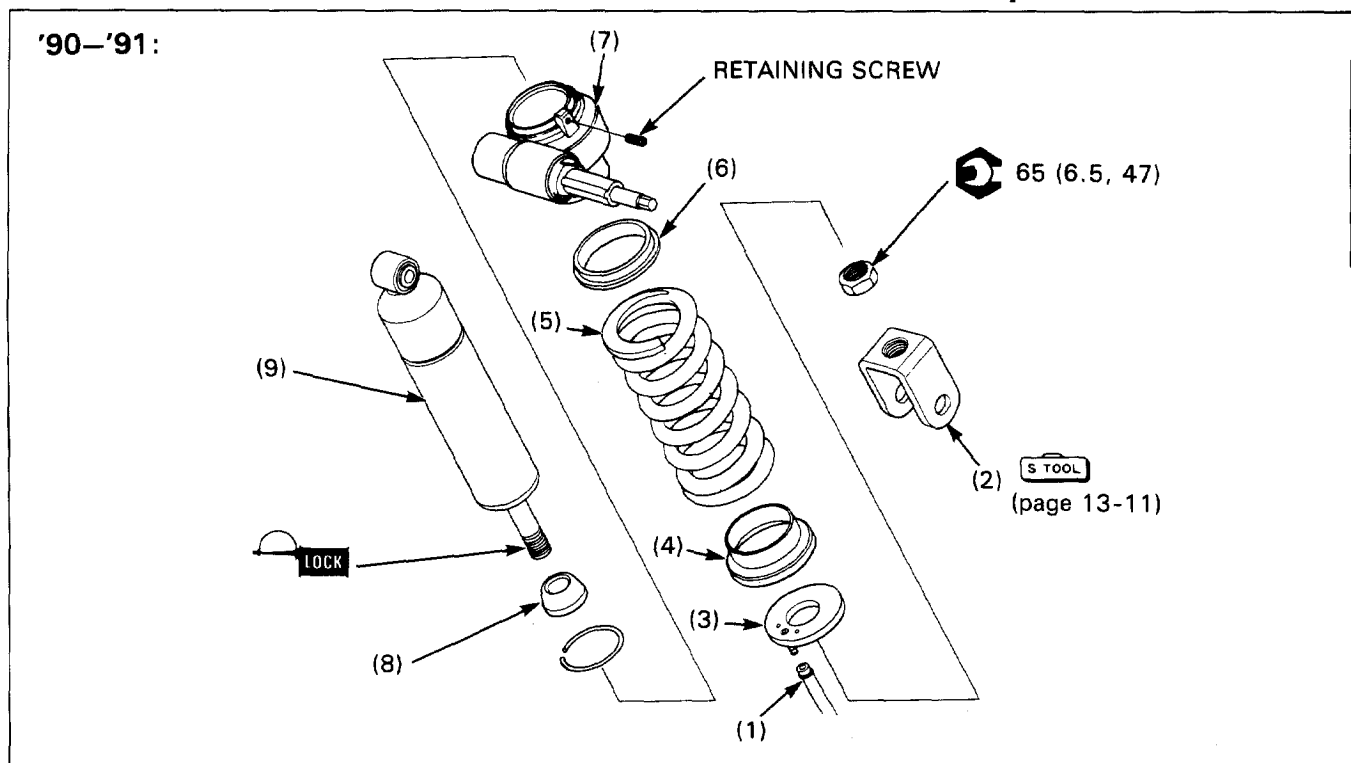

**▲ WARNING**

- The shock absorber contains nitrogen under high pressure. Do not allow fire or heat near the shock absorber.
- Before disposal of the shock absorber, release the nitrogen.

(See: section 19 of the Common Service Manual; Drilling point for disposal: page 1-13)

## Requisite Service

- Shock absorber removal/installation (page 13-6)

Procedure		Q'ty	Remarks
	<b>Disassembly Order</b>		• Assembly is in the reverse order of disassembly.
(1)	Drain tube	1	NOTE: • Refer to page 13-11 for removal/installation.
(2)	Lower joint	1	
(3)	Spring seat stopper	1	Install with the tapered end facing the adjuster.
(4)	Spring seat	1	
(5)	Spring	1	Remove after loosening the retaining screw. Install so that retaining screw aligns with the "O" mark on the damper.
(6)	Spring seat	1	
(7)	Adjuster	1	Apply a locking agent to the damper rod threads at assembly.
(8)	Damper rubber	1	
(9)	Damper assembly	1	

## Lower Joint Removal/Installation

Install the shock absorber compressor and attachment on the rear shock absorber as shown.

**S TOOL**

**Shock absorber compressor**                    **07GME-0010000**  
 or **07959-3290001**  
 — screw assembly                                **07GME-0010100**  
**Attachment**                                        **07959-MB10000**

Turn the compressor handle and slowly compress the spring.

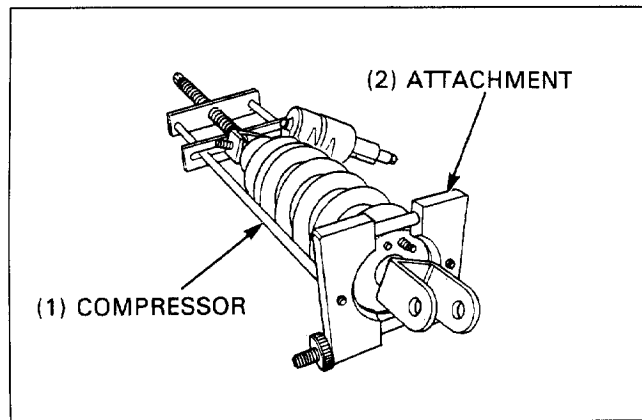

Hold the lower joint and loosen the lock nut (turn the nut clockwise).

Remove the lower joint and clean off any locking agent from the threads.

Apply a locking agent to the damper rod threads.  
 Install the lower joint securely onto the damper rod.  
 Hold the lower joint and torque the lock nut.

**Torque: 65N · m (6.5kg-m, 47ft-lb)**

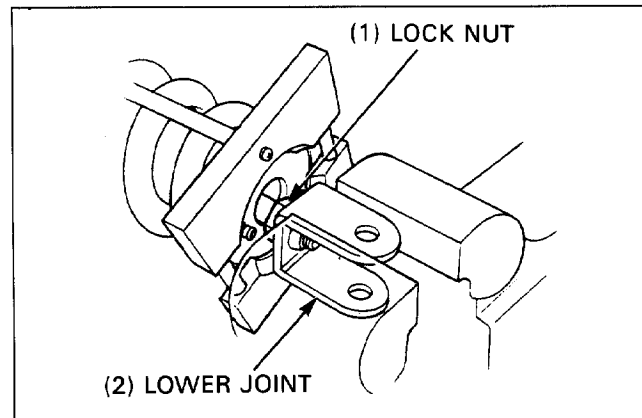

### NOTE

- Install the spring seat stopper with the projections facing forward.
- Install the lower joint aligning the edge of the joint with the projections on the spring seat stopper.

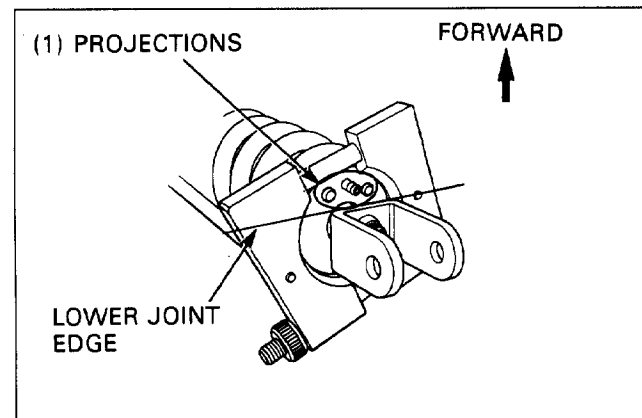

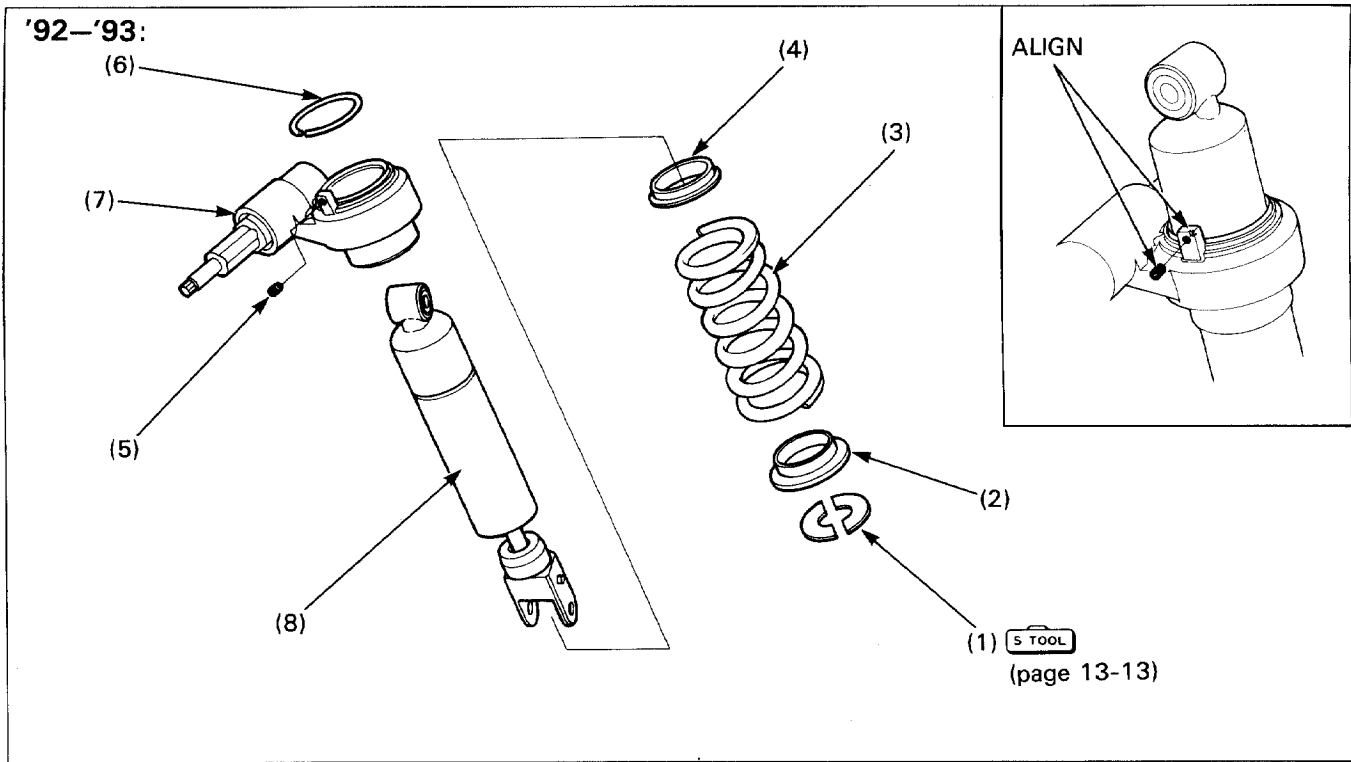

**⚠ WARNING**

- The shock absorber nitrogen under high pressure. Do not allow fire or heat near the shock absorber.
  - Before disposal of the shock absorber, release the nitrogen.
- (See: section 19 of the Common Service Manual; Drilling point for disposal: 1-13)

**Requisite Service**

- Shock absorber removal/installation (page 13-6)

Procedure	Q'ty	Remarks
<b>Disassembly Order</b>		
(1) Stopper plate	2	Assembly is in the reverse order of disassembly. <b>NOTE:</b> • Refer to page 13-13 for removal/installation.
(2) Spring seat	1	
(3) Spring	1	Install with the tapered end facing the adjuster.
(4) Spring seat	1	
(5) Retaining screw	1	Install so that retaining screw aligns the "O" mark on the damper.
(6) Stopper ring	1	
(7) Adjuster	1	Install so that retaining screw aligns the "O" mark on the damper.
(8) Damper assembly	1	

**Stopper Plate Removal/Installation**

Install the shock absorber compressor and attachment on the rear shock absorber as shown.

**S TOOL**

**Shock absorber compressor** 07GME-0010000

**Attachment** 07NME-MY70100

Turn the compressor handle and slowly compress the spring.

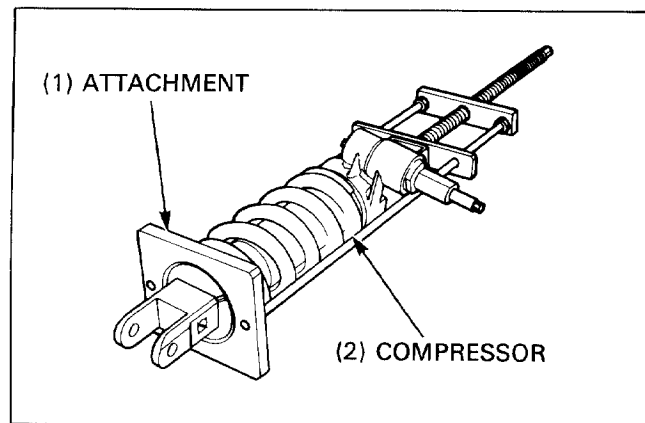

Remove the stopper plates from the spring seat.

Remove the shock absorber spring.

Install the shock absorber spring with the tapered end facing the adjuster.

Compress the spring with the compressor and attachment.

Install the stopper plate securely.

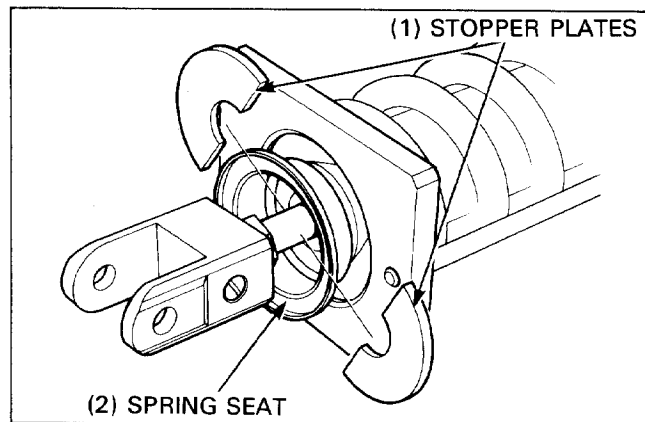

# Suspension Linkage Removal/Installation

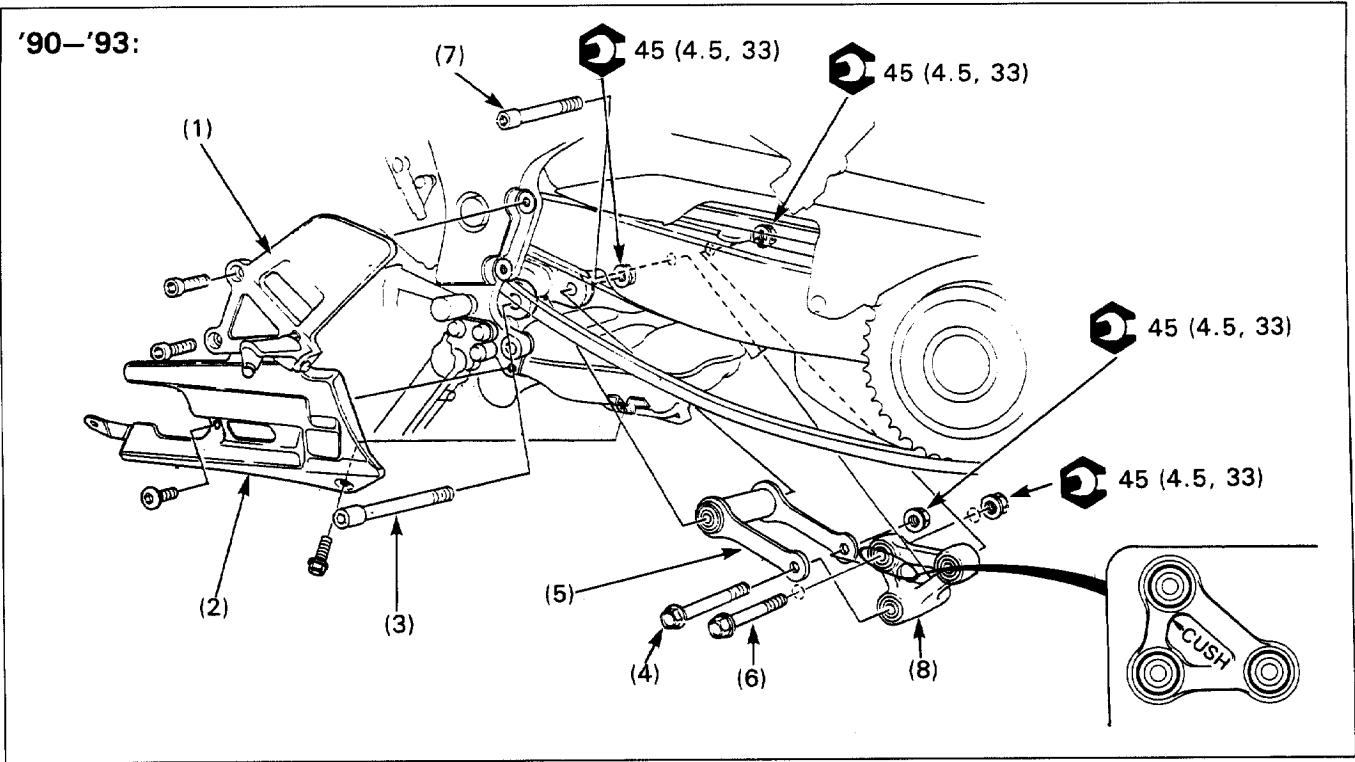

**NOTE**

- Support the motorcycle by placing a support block under the exhaust system or with the optional center stand.

Procedure	Q'ty	Remarks
<b>Removal Order</b>		• Installation is in the reverse order of removal.
(1) Left footpeg stay	1	
(2) Exhaust chamber guard	1	
(3) Cushion rod-to-frame bolt	1	— Insert from the left side.
(4) Cushion rod-to-shock arm bolt	1	
(5) Cushion rod	1	
(6) Shock absorber mounting bolt (lower)	1	— Insert from the left side.
(7) Shock arm-to-swingarm bolt	1	
(8) Shock arm	1	Install the shock arm so that the pivot identified by "←CUSH." fits with the lower joint as shown.

## Suspension Linkage Disassembly/Assembly

'90-'93:

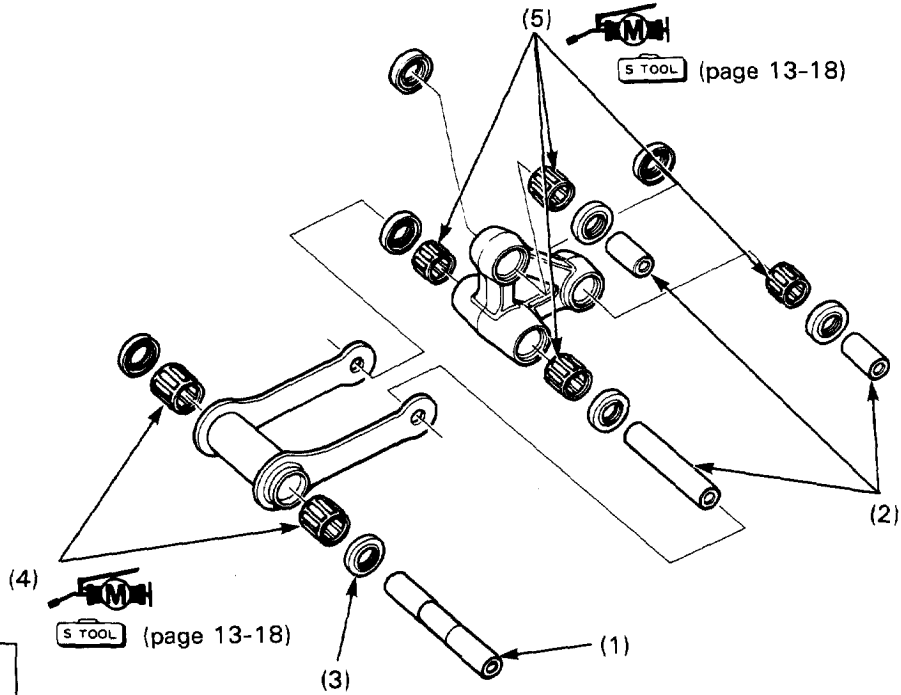

## NOTE

- Support the motorcycle by placing a support block under the exhaust system or with the optional centerstand.

## Requisite Service

- Suspension linkage removal/installation (page 13-14).

Procedure		Q'ty	Remarks
<b>Removal Order</b>			• Installation is in the reverse order of removal.
(1)	Cushion rod pivot collar	1	
(2)	Shock arm pivot collar	3	
(3)	Dust seal	8	When installing, apply molybdenum disulfide grease to the dust seal lips.
(4)	Cushion rod needle bearing	2	Refer to page 13-18 for replacement.
(5)	Shock arm needle bearing	4	Refer to page 13-18 for replacement.

After '93:

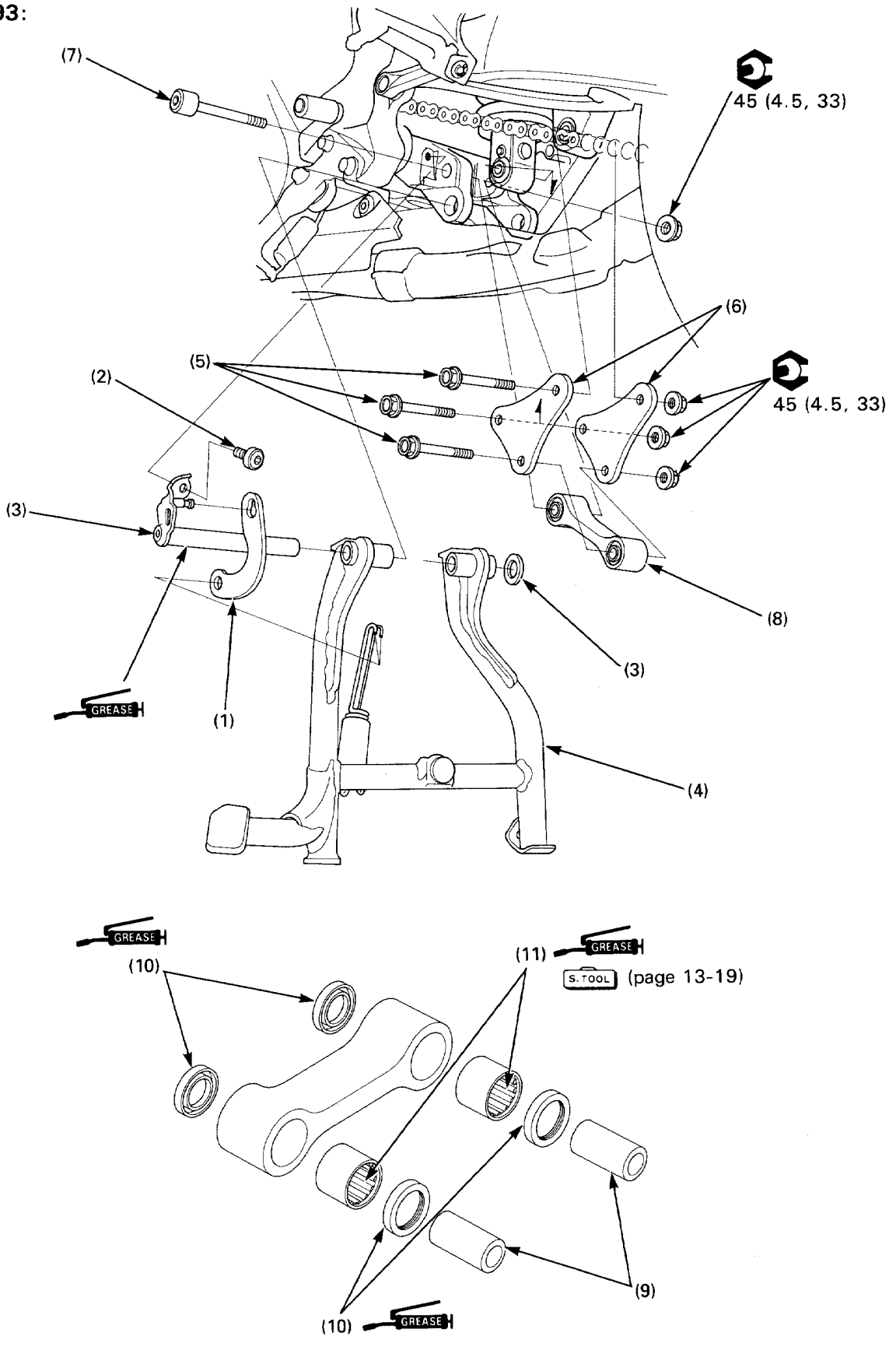

## NOTE

- Support the motorcycle securely in an upright position using a safety stand or hoist.

Procedure		Q'ty	Remarks
	<b>Disassembly Order</b>		Assebly is in the reverse order of disassembly.
(1)	Center stand spring bracket	1	
(2)	Socket bolt	1	
(3)	Pivot shaft/washer	1/1	
(4)	Center stand	1	
(5)	Shock arm plate bolt	3	
(6)	Shock arm plate	2	
(7)	Shock link bolt	1	
(8)	Shock link assembly	1	
(9)	Pivot collar	2	
(10)	Dust seal	4	
(11)	Needle bearing	2	Replacement (page 13-19)

## Cushion Rod Pivot Bearing Replacement

('90-'93)

### Removal

Remove the needle bearings out of the cushion rod.

**S TOOL**

**Bearing remover**

**07936-3710300**

**Remover handle**

**07936-3710100**

**Remover sliding weight**

**07741-0010201**

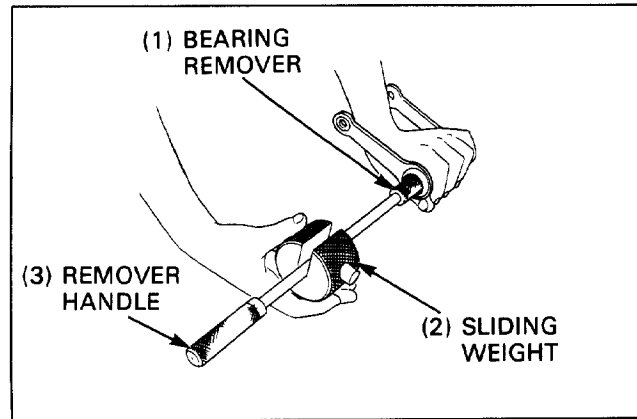

### Installation

Fill new needle bearings with molybdenum disulfide grease. Press in the needle bearing until the attachment face seats against the cushion rod.

### NOTE

- Press in the new needle bearings with their markings facing out.

**S TOOL**

**Driver**

**07749-0010000**

**Attachment, 24×26mm**

**07746-0010700**

**Pilot, 17mm**

**07746-0040400**

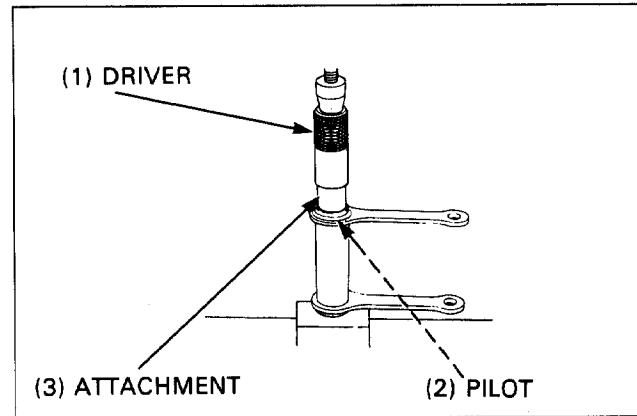

## Shock Arm Pivot Bearing Replacement

('90-'93)

### Removal

Press the needle bearings out of the shock arm.

**S TOOL**

**Pin driver assembly**

**07GMD-KT80100**

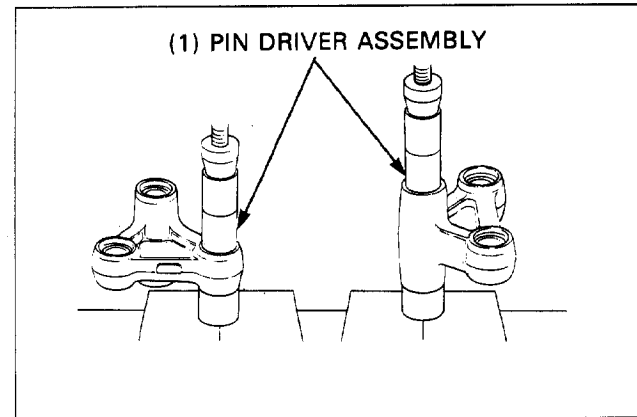

### Installation

Fill new needle bearings with molybdenum disulfide grease. Press in the needle bearing until the attachment face seats against the shock arm.

### NOTE

- Press in the new needle bearings with their markings facing out.

**S TOOL**

**Driver**

**07749-0010000**

**Attachment, 24×26mm**

**07746-0010700**

**Pilot, 17mm**

**07746-0040400**

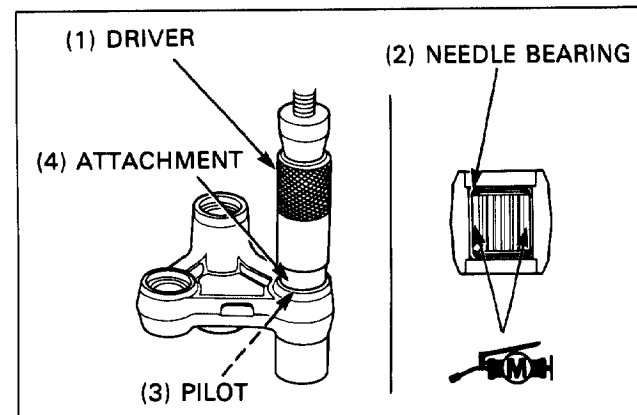

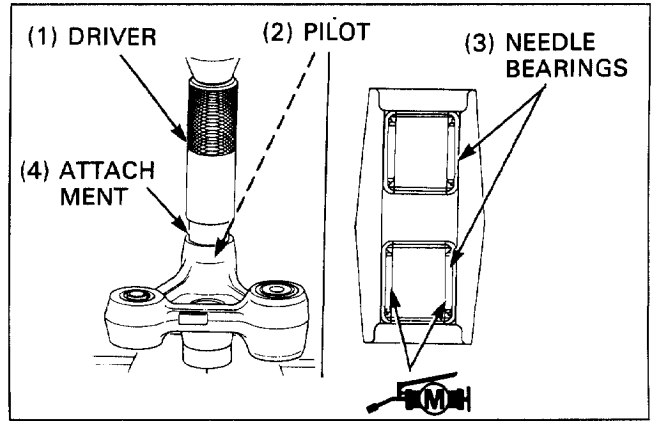

**Shock Link Bearing Replacement (After '93)**

Press the needle bearings out of the shock link.

S. TOOL

**Pin driver assembly**

**07GMD-KT80100**

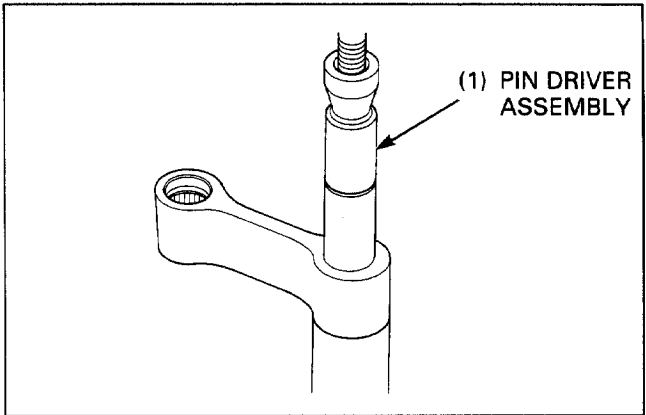

Press a new needle bearings into the shock link so that the needle bearing surface is lower 5.5 mm (0.22 in ) from the end of the shock link.

S. TOOL

**Driver**  
**Attachment, 24 x 26 mm**  
**Pilot, 17 mm**

**07749-0010000**  
**07746-0010700**  
**07746-0040400**

**NOTE**

- Press the bearing with the marked side facing up.

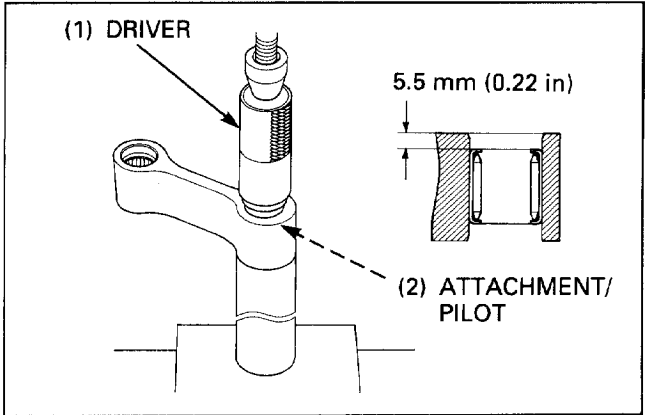

# Swingarm Removal/Installation

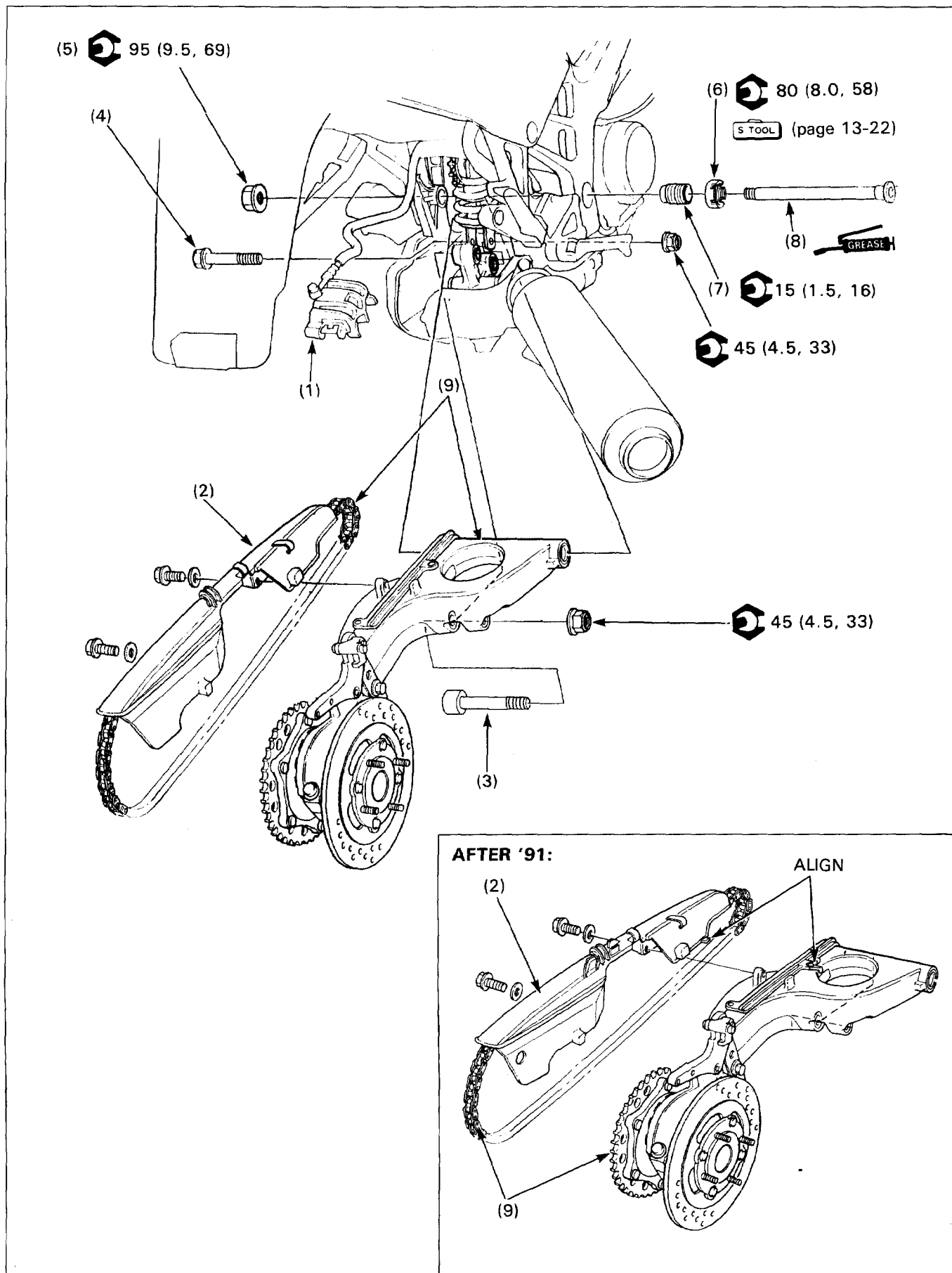

## NOTE

- Support the motorcycle by placing a support block under the exhaust system or with the optional center stand.
- If necessary, loosen the rear engine mounting nut near the swingarm pivot to ease the swingarm removal/installation.
- Do not depress the brake pedal when the caliper is removed, or it will be difficult to refit the disc between the brake pads.
- Support the removed caliper with a piece of wire so that it does not hang from the brake hose. Do not twist the brake hose.
- It is not necessary to disconnect the brake hose.

## Requisite Service

- Rear wheel removal/installation (page 13-2)

Procedure		Q'ty	Remarks
<b>Removal Order</b>			
(1)	Rear brake caliper	1	Refer to page 14-10 for removal. After removing, release the brake hose from the clamps on the chain cover.
(2)	Drive chain cover	1	
(3)	Shock arm-to-swingarm bolt	1	
(4)	Shock absorber mounting bolt (lower)	1	
(5)	Swingarm pivot nut	1	
(6)	Adjusting bolt lock nut	1	
(7)	Adjusting bolt	1	
(8)	Swingarm pivot bolt	1	
(9)	Swingarm assembly/drive chain	1/1	
<b>Installation Order</b>			
(9)	Swingarm assembly/drive chain	1/1	Place the chain on the sprocket first. Temporarily install by hand-threading. Refer to page 13-22 for tightening. Insert into the adjusting bolt so that the hexagonal portions mate. Refer to page 13-22 for tightening. Temporarily install by hand-threading. Refer to page 13-22 for tightening. Insert the projections of the cover into the swingarm tabs. Refer to page 14-10 for installation. After installing, secure the brake hose with the clamps on the chain cover.
(8)	Adjusting bolt	1	
(7)	Swingarm pivot bolt	1	
(6)	Adjusting bolt lock nut	1	
(5)	Swingarm pivot nut	1	
(4)	Shock absorber mounting bolt (lower)	1	
(3)	Shock arm-to-swingarm bolt	1	
(2)	Drive chain cover	1	
(1)	Rear brake caliper	1	

## Swingarm Pivot Bolt Installation

Apply grease to the swingarm pivot bolt. Tighten the adjusting bolt fully by hand then insert the swingarm pivot bolt through the adjusting bolt so that the hexagonal portions mate.

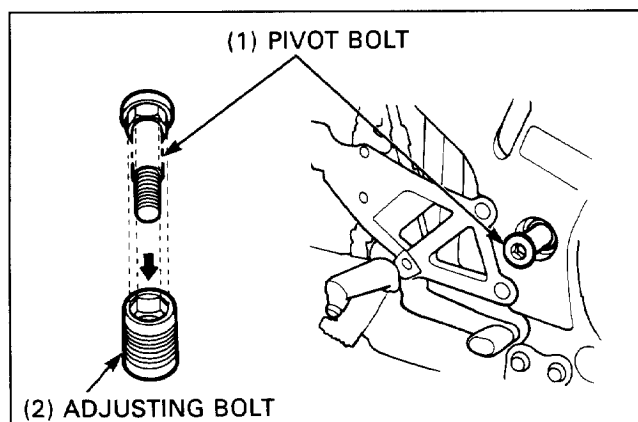

Tighten the adjusting bolt with the swingarm pivot bolt as shown.

**Torque: 15 N·m (1.5 kg-m, 16 ft-lb)**

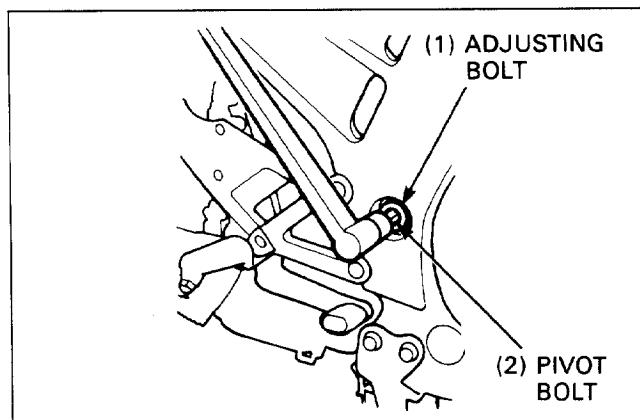

Tighten the adjusting bolt lock nut fully by hand, then tighten the lock nut holding the swingarm pivot bolt as shown.

**Torque: 80 N·m (8.0 kg-m, 58 ft-lb)**

**S TOOL**

**Swingarm pivot lock nut wrench 07908-4690002**

Tighten the swingarm pivot lock nut.

**Torque: 95 N·m (9.5 kg-m, 69 ft-lb)**

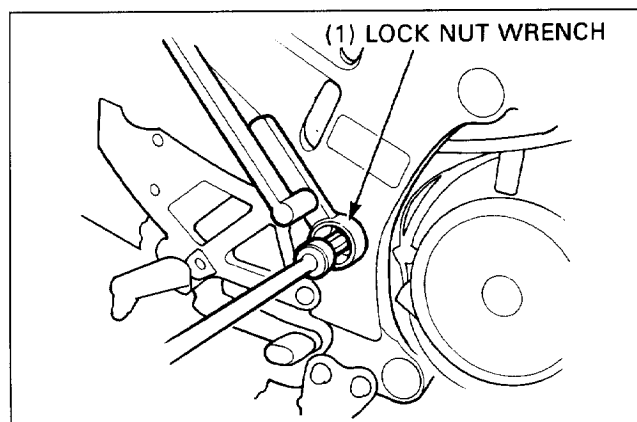

# Swingarm Disassembly/Assembly

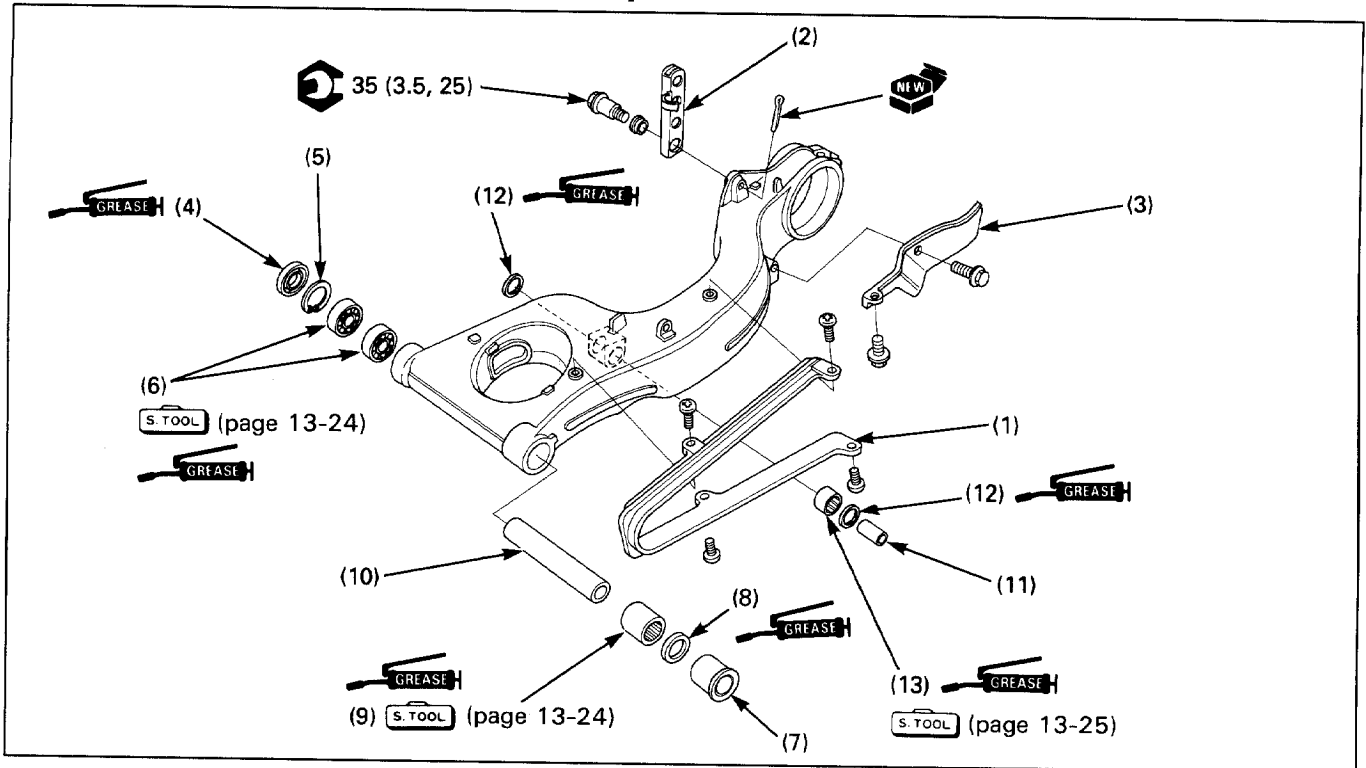

## Requisite Service

• Rear wheel removal/installation (page 13-2)

• Swingarm removal/installation (page 13-20)

Procedure		Q'ty	Remarks
<b>Disassembly Order</b>			Assembly is in the reverse order of disassembly.
(1)	Drive chain slider	1	
(2)	Brake torque rod	1	
(3)	Mud guard	1	
(4)	Dust seal	1	
(5)	Snap ring	1	Install the chamfered side facing in.
(6)	Right swingarm pivot bearing	2	Replacement (page 13-24)
(7)	Swingarm pivot collar	1	
(8)	Dust seal	1	
(9)	Left swingarm pivot bearing	1	Replacement (page 13-24)
(10)	Distance collar	1	
<b>After '93:</b>			
(11)	Shock arm pivot collar	1	
(12)	Dust seal	2	
(13)	Needle bearing	1	Replacement (page 13-25)

## Swingarm Pivot Bearing Replacement

### Right Pivot Bearing Removal

Remove the dust seal and snap ring.  
Remove the ball bearings from the swingarm pivot.



**Bearing remover set**

**07936-3710001**

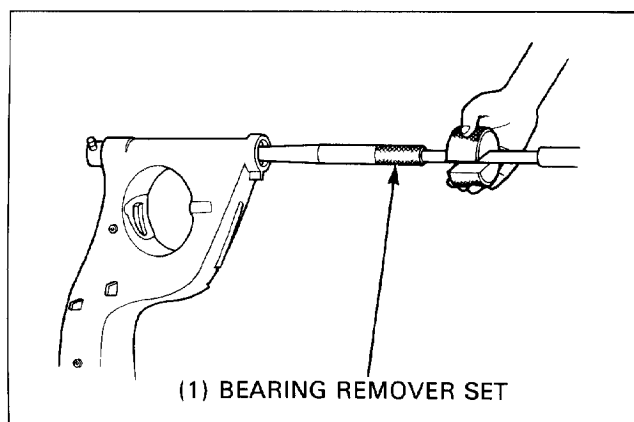

### Left Pivot Bearing Removal

Remove the pivot collar and dust seal.  
Drive the needle bearing out of the swingarm pivot.



**Needle bearing remover  
Driver shaft**

**07HMC-MR70100  
07946-MJ00100**

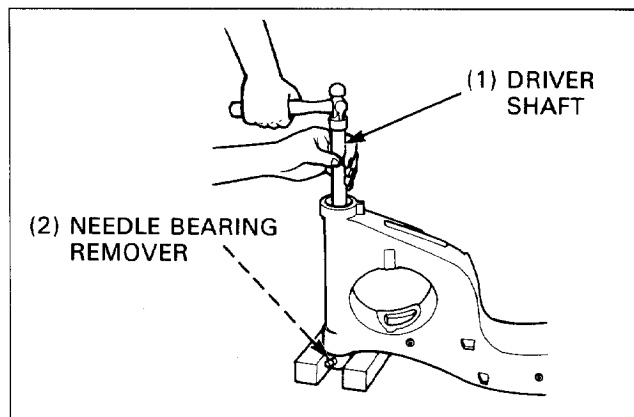

### Left Pivot Bearing Installation

Pack the new needle bearing with grease.  
Press in the needle bearing with its markings facing out.

#### NOTE

- Press the needle bearing so that the bearing end is 4 mm below the swingarm edge as shown.



**Driver  
Attachment, 37×40mm  
Pilot, 28mm**

**07749-0010000  
07746-0010200  
07746-0041100**

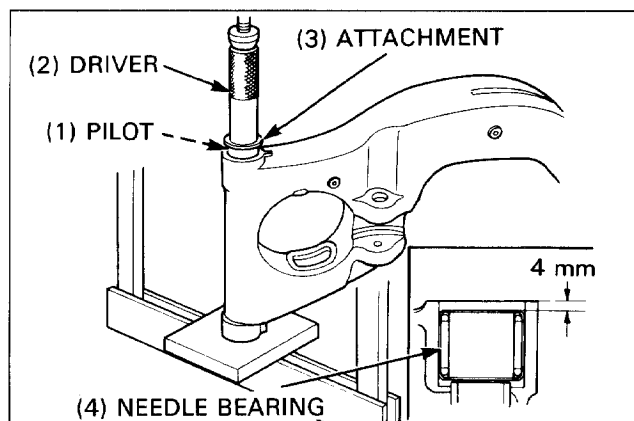

### Right Pivot Bearing Installation

Pack the new ball bearings with grease.  
One at a time, drive in the ball bearings fully.

#### NOTE

- Drive in the bearings with their markings facing out.



**Driver  
Attachment, 37×40mm  
Pilot, 20mm**

**07749-0010000  
07746-0010200  
07746-0040500**

Install the snap ring and dust seal.

#### NOTE

- Install the snap ring with the chamfered side facing the bearing.

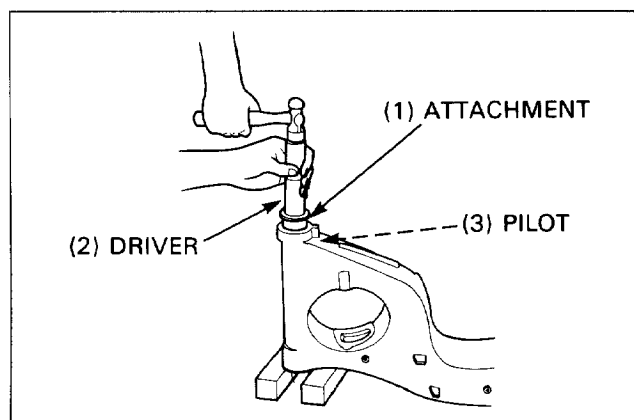

## Shock Arm Pivot Bearing Replacement (After '93)

### Removal

Remove the pivot collar and dust seals.  
Press the needle bearing out of the swingram.

**S TOOL**

Pin driver assembly

07GMD-KT80100

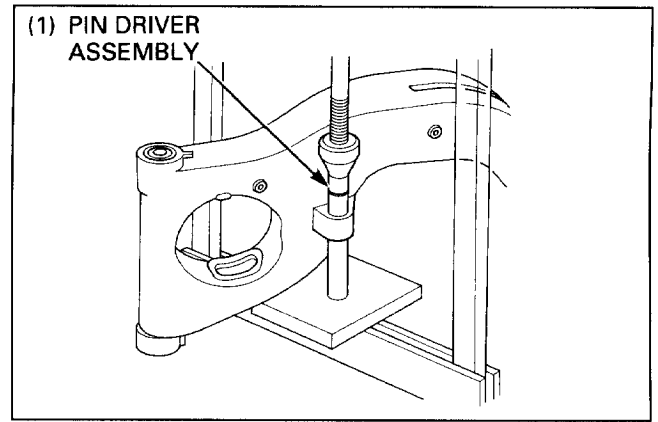

### Installation

Pack the new needle bearing with grease.  
Press the needle bearing into the swingram so that the needle bearing surface is lower 5.5 mm (0.22 in) from the end of the swingram.

**S TOOL**

Driver  
Attachment, 24 x 26 mm  
Pilot, 17 mm

07749-001000

07746-0010700

07746-0040400

### NOTE

- Press the bearing with the marked side facing up.

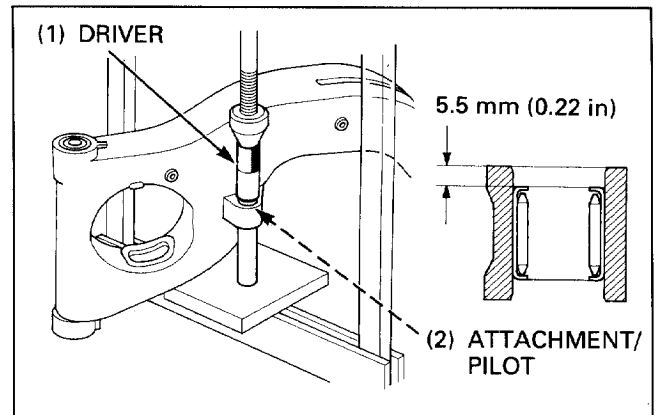



# 14. Brakes

Service Information	14-1	Front Brake Caliper Disassembly/ Assembly	14-7
Troubleshooting	14-1		
Front Brake Pad Replacement	14-2	Rear Master Cylinder Removal/ Installation	14-8
Rear Brake Pad Replacement	14-3	Rear Master Cylinder Disassembly/ Assembly	14-9
Front Master Cylinder Disassembly/ Assembly	14-4	Rear Brake Caliper Removal/ Installation	14-10
Front Brake Caliper Removal/ Installation	14-6	Rear Brake Caliper Disassembly/ Assembly	14-11
		Brake Pedal Removal/ Installation	14-12

## Service Information

### ⚠ WARNING

- A contaminated brake disc or pad reduces stopping power. Discard contaminated pads and clean a contaminated disc with a high quality brake degreasing agent.
- Inhaled asbestos fibers have been found to cause respiratory disease and cancer. Never use an air hose or dry brush to clean brake assemblies. Use an OSHA-approved vacuum cleaner or alternate method approved by OSHA designed to minimize the hazard caused by airborne asbestos fibers.

- Spilled brake fluid will severely damage instrument lenses and painted surfaces. It is also harmful to some rubber parts. Be very careful whenever you remove the reservoir cap: make sure the front reservoir is horizontal first.
- Never allow contaminants (dirt, water, etc.) to get into an open reservoir.
- Once the hydraulic system has been opened, or if the brakes feel spongy, the system must be bled.
- Always use fresh DOT 4 brake fluid from a sealed container when servicing the system. Do not mix different types of fluid as they may not be compatible.
- Always check brake operation before riding the motorcycle.

14

## Troubleshooting

### Brake lever/pedal soft or spongy

- Air bubbles in the hydraulic system
- Leaking hydraulic system
- Contaminated brake pad/disc
- Worn caliper piston seal
- Worn master cylinder piston cups
- Worn brake pad
- Contaminated caliper
- Caliper not sliding properly
- Worn brake pad/disc
- Low fluid level
- Clogged fluid passage
- Warped/deformed brake disc
- Sticking/worn caliper piston
- Sticking/worn master cylinder piston
- Worn brake disc
- Contaminated master cylinder
- Bent brake lever/pedal

### Brake lever/pedal hard

- Clogged/restricted brake system
- Sticking/worn caliper piston
- Caliper not sliding properly
- Clogged/restricted fluid passage
- Worn caliper piston seal
- Sticking/worn master cylinder piston
- Bent brake lever/pedal

### Brakes drag

- Contaminated brake pad/disc
- Misaligned wheel
- Worn brake pad/disc
- Warped/deformed brake disc
- Caliper not sliding properly
- Caliper pivot collar not lubricated properly

# Front Brake Pad Replacement

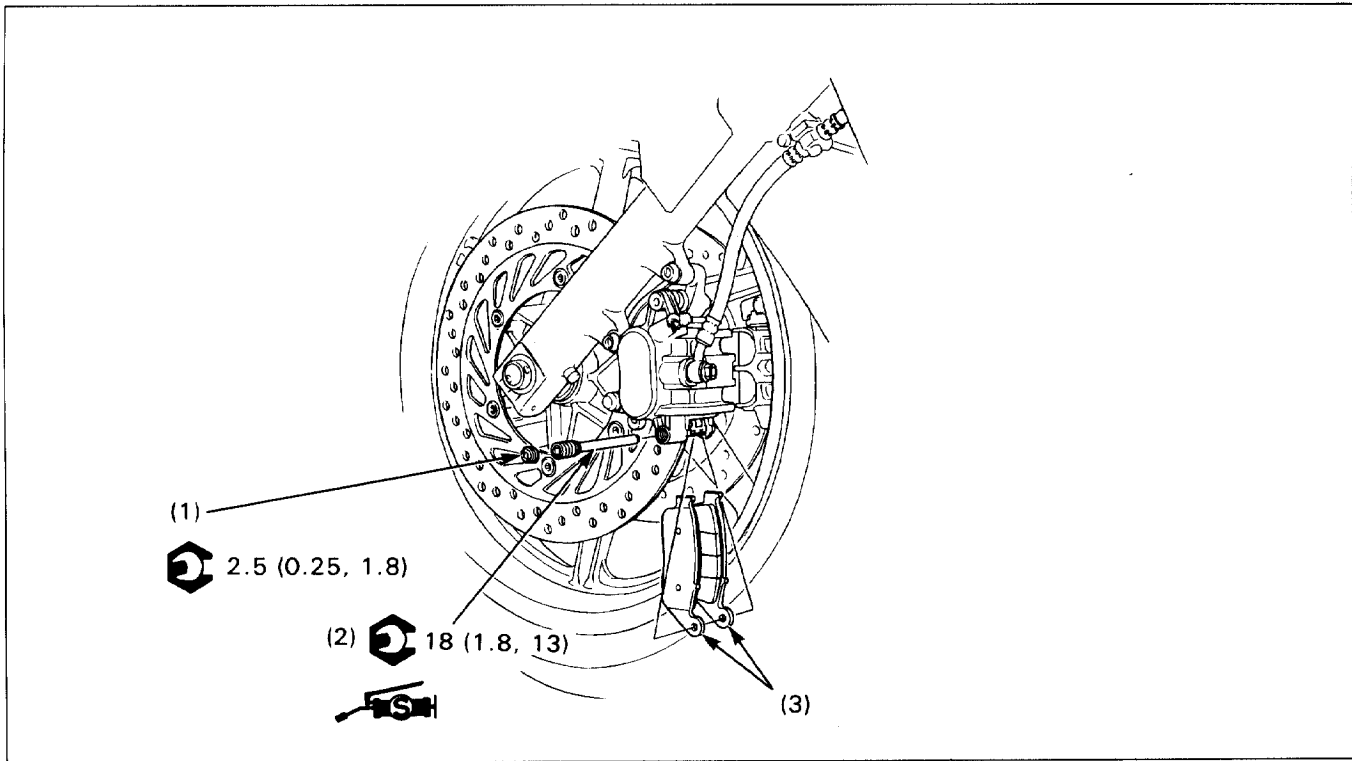

**⚠ WARNING**

- A contaminated brake disc or pad reduces stopping power. Discard contaminated pads and clean a contaminated disc with a high quality brake degreasing agent.
- Inhaled asbestos fibers have been found to cause respiratory disease and cancer. Never use an air hose or dry brush to clean brake assemblies. Use an OSHA-approved vacuum cleaner or alternate method approved by OSHA designed to minimize the hazard caused by airborne asbestos fibers.

**NOTE**

- Do not depress the brake lever when the caliper is removed, or it will be difficult to refit the disc between the brake pads.
- Replace brake pads as a set.
- Apply a thin coat of silicone grease onto the pad pin as a rust preventative.

**Requisite Service**

- Pushing the caliper against the disc, push the caliper pistons all the way in to allow the installation of new brake pads.

Procedure		Q'ty	Remarks
<b>Removal Order</b>			• Installation is in the reverse order of removal.
(1)	Pad pin plug	1	
(2)	Pad pin	1	Insert the pin, pushing the pads against the pad spring.
(3)	Brake pad	2	Align the pad lug with the pad retainer as shown.

## Rear Brake Pad Replacement

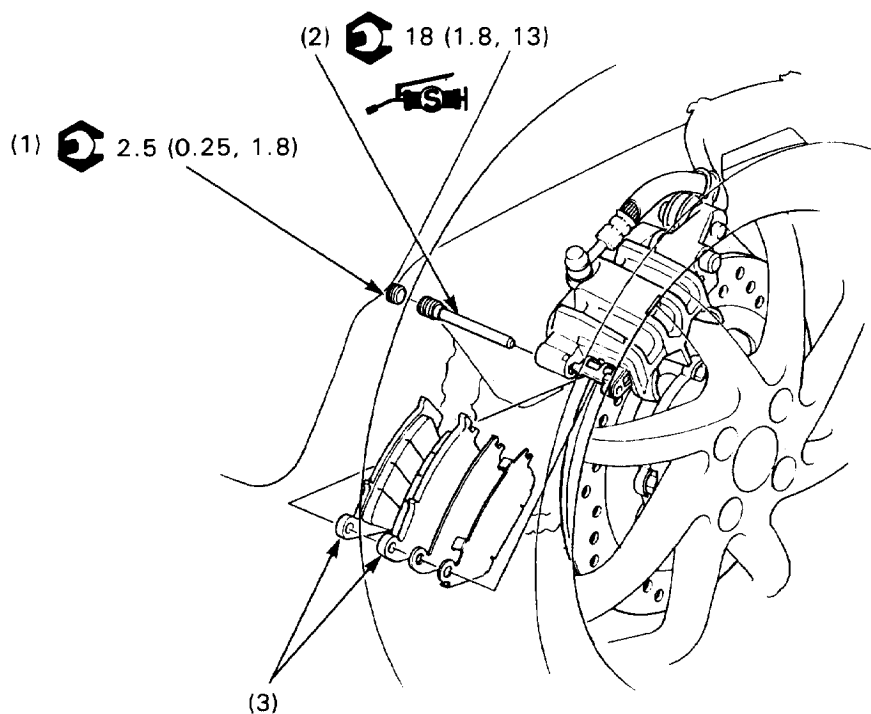

### WARNING

- A contaminated brake disc or pad reduces stopping power. Discard contaminated pads and clean a contaminated disc with a high quality brake degreasing agent.
- Inhaled asbestos fibers have been found to cause respiratory disease and cancer. Never use an air hose or dry brush to clean brake assemblies. Use an OSHA-approved vacuum cleaner or alternate method approved by OSHA designed to minimize the hazard caused by airborne asbestos fibers.
- After replacement, operate the brake pedal to seat the caliper pistons against the pads.

### NOTE

- Do not depress the brake pedal when the caliper is removed, or it will be difficult to refit the disc between the brake pads.
- Replace brake pads as a set.
- Apply a thin coating of silicone grease onto the pad pins to prevent rust and allow easy pad movement.

### Requisite Service

- Pushing the caliper against the disc, push the caliper piston all the way in to allow the installation of new brake pads.

Procedure	Q'ty	Remarks
<b>Removal Order</b>		• Installation is in the reverse order of removal.
(1) Pad pin plug	1	
(2) Pad pin	1	Insert the pin, pushing the pads against the pad spring.
(3) Brake pad	2	Align the pad lug with the pad retainer.

# Front Master Cylinder Disassembly/Assembly

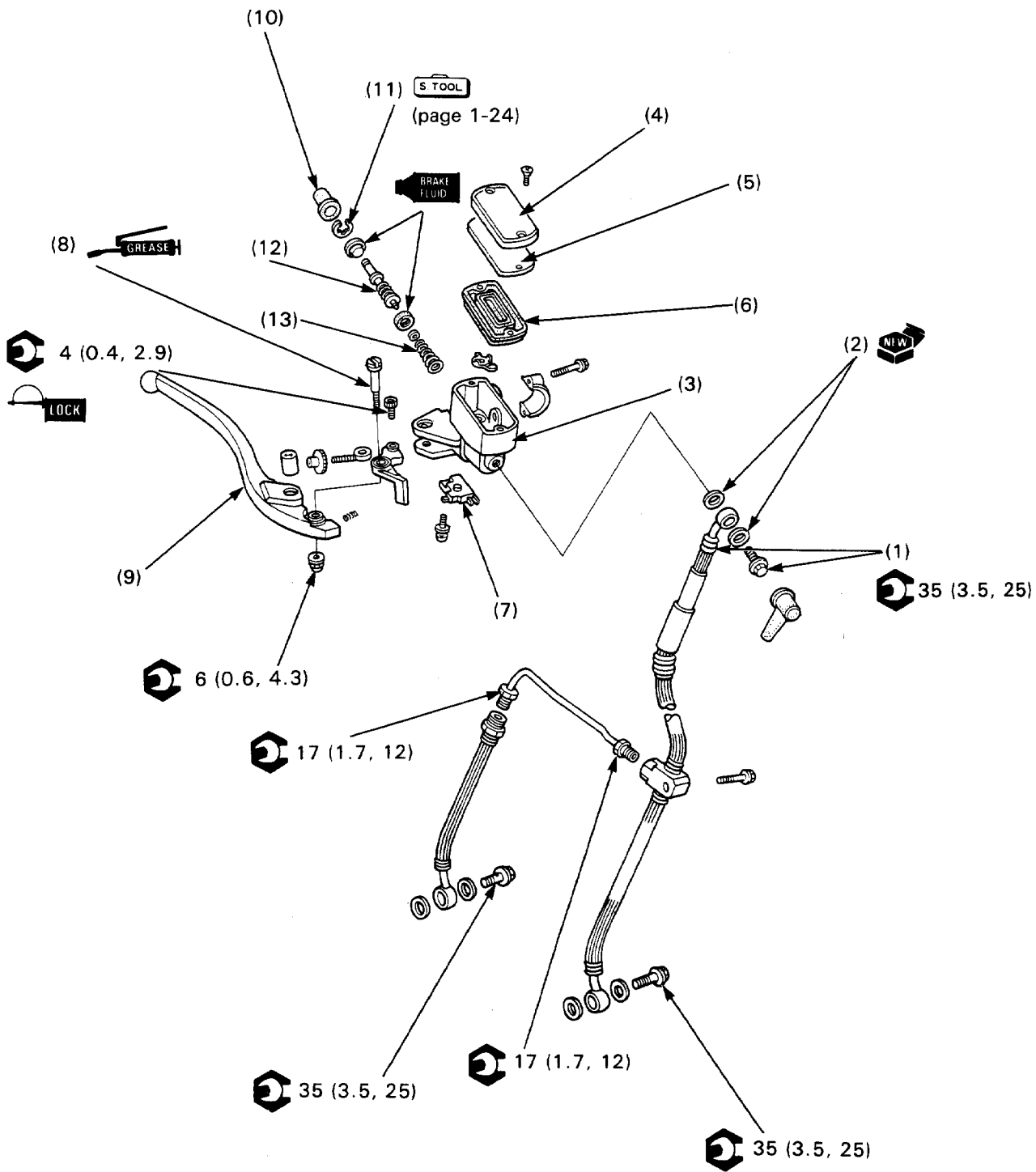

## NOTE

- Replace the master piston, spring, cups, stopper plate, snap ring and boot as a set.
- The master cylinder piston, cups and spring must be installed as a set.

## Requisite Service

- Air bleeding (section 17 of the Common Service Manual)
- Front master cylinder removal/installation (page 12-2)

Procedure		Q'ty	Remarks
	<b>Disassembly Order</b>		• Assembly is in the reverse order of disassembly.
(1)	Brake hose bolt/brake hose	1/1	Refer to page 1-29 for correct routing.
(2)	Sealing washer	2	
(3)	Master cylinder assembly	1	
(4)	Reservoir cover	1	
(5)	Diaphragm plate	1	
(6)	Diaphragm	1	
(7)	Front brake light switch	1	
(8)	Brake lever pivot bolt	1	When installing, apply grease on the brake lever sliding surface.
(9)	Brake lever assembly	1	
(10)	Boot	1	
(11)	Snap ring	1	NOTE: • Install the snap ring with the chamfered side facing inside. • Make sure the snap ring is fully seated in the groove.
(12)	Master piston assembly	1	
(13)	Spring	1	Install with its tapered end toward the piston.

# Front Brake Caliper Removal/Installation

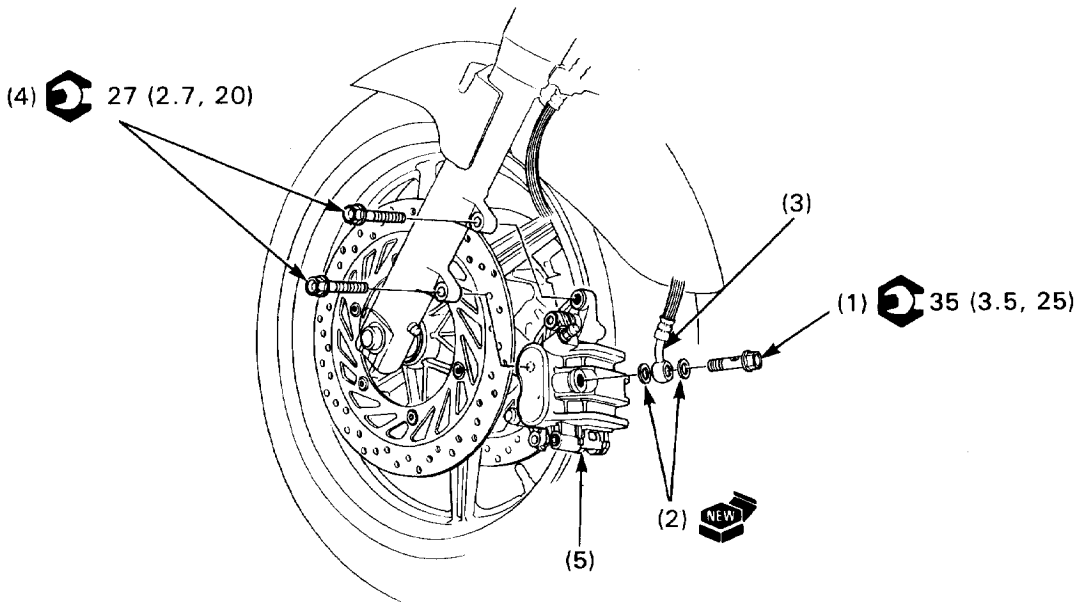

**⚠ WARNING**

- A contaminated brake disc or pad reduces stopping power. Discard contaminated pads and clean a contaminated disc with a high quality brake degreasing agent.
- Inhaled asbestos fibers have been found to cause respiratory disease and cancer. Never use an air hose or dry brush to clean brake assemblies. Use an OSHA-approved vacuum cleaner or alternate method approved by OSHA designed to minimize the hazard caused by airborne asbestos fibers.

**NOTE**

- If you remove the caliper pistons, remove the caliper bracket bolts (4) before disconnecting the brake hose (3) ; and place a pan under the caliper to catch the draining fluid and squeeze the brake lever slowly to push out the pistons.

**Requisite Service**

- Brake pad removal/installation (page 14-2)
- Brake fluid replacement/air bleeding (section 17 of the Common Service Manual)

Procedure	Q'ty	Remarks
<b>Removal Order</b>		• Installation is in the reverse order of removal.
(1) Brake hose bolt	1	
(2) Sealing washer	2	
(3) Brake hose	1	At installation, press the hose end against the stopper while tightening the hose bolt.
(4) Caliper bracket bolt	2	
(5) Front brake caliper assembly	1	

# Front Brake Caliper Disassembly/Assembly

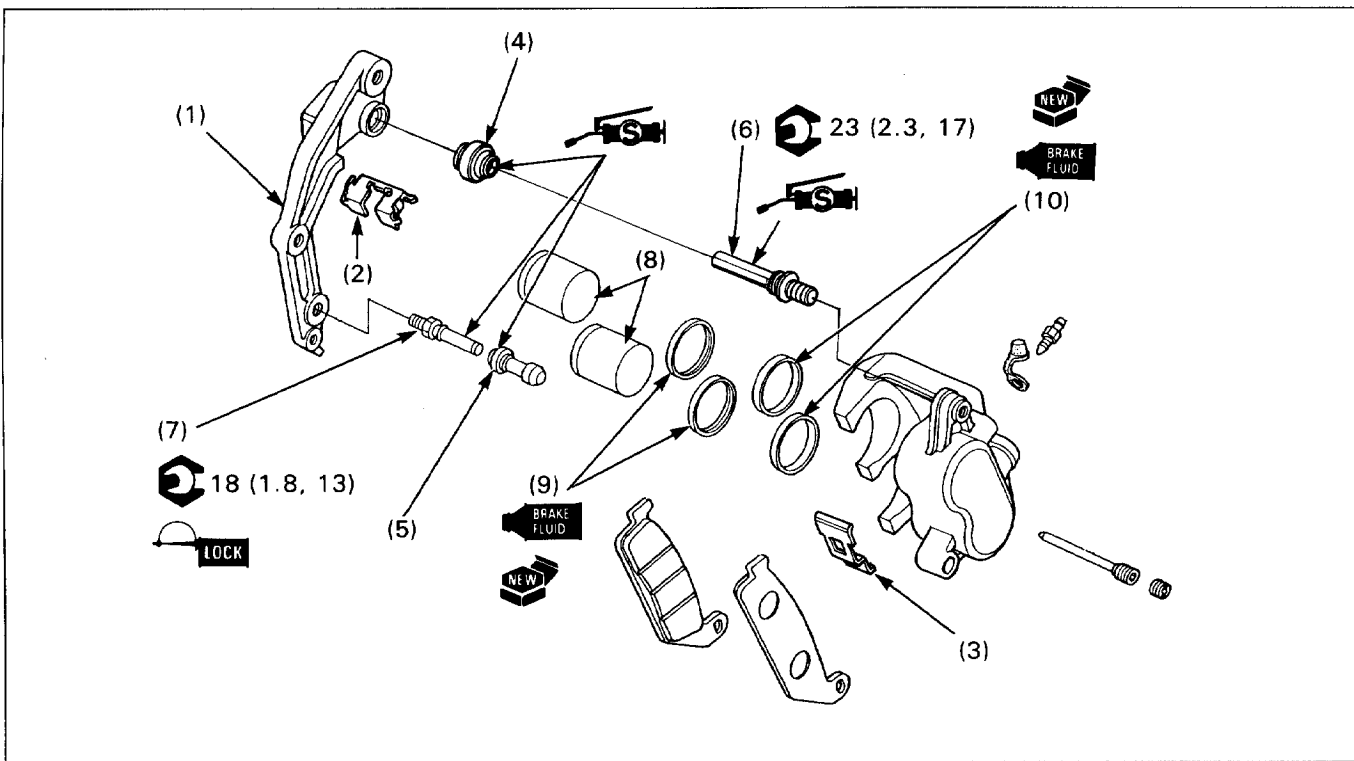

**WARNING**

Inhaled asbestos fibers have been found to cause respiratory disease and cancer. Never use an air hose or dry brush to clean brake assemblies. Use an OSHA-approved vacuum cleaner or alternate method approved by OSHA designed to minimized the hazard caused by airborne asbestos fibers.

**NOTE**

- Do not remove the pin bolts without necessity.

**Requisite Service**

- Front brake pad removal/installation (page 14-2)
- Front brake caliper removal/installation (page 14-6)
- Brake fluid replacement/air bleeding (section 17 of the Common Service Manual)

Procedure	Q'ty	Remarks
<b>Disassembly Order</b>		• Assembly is in the reverse order of disassembly.
(1) Front brake caliper bracket	1	
(2) Brake pad retainer	1	
(3) Pad spring	1	Note the spring direction.
(4) Caliper pin bolt boot	1	
(5) Bracket pin bolt boot	1	
(6) Caliper pin bolt	1	Apply a locking agent to the threads and torque it. Apply silicone grease to the pin.
(7) Bracket pin bolt	1	Apply silicone grease to the pin.
(8) Caliper piston	2	Install them with the concaved side away from the pad.
(9) Dust seal	2	<b>CAUTION:</b> • Be careful not to damage the piston sliding surface when removing seals.
(10) Piston seal	2	

# Rear Master Cylinder Removal/Installation

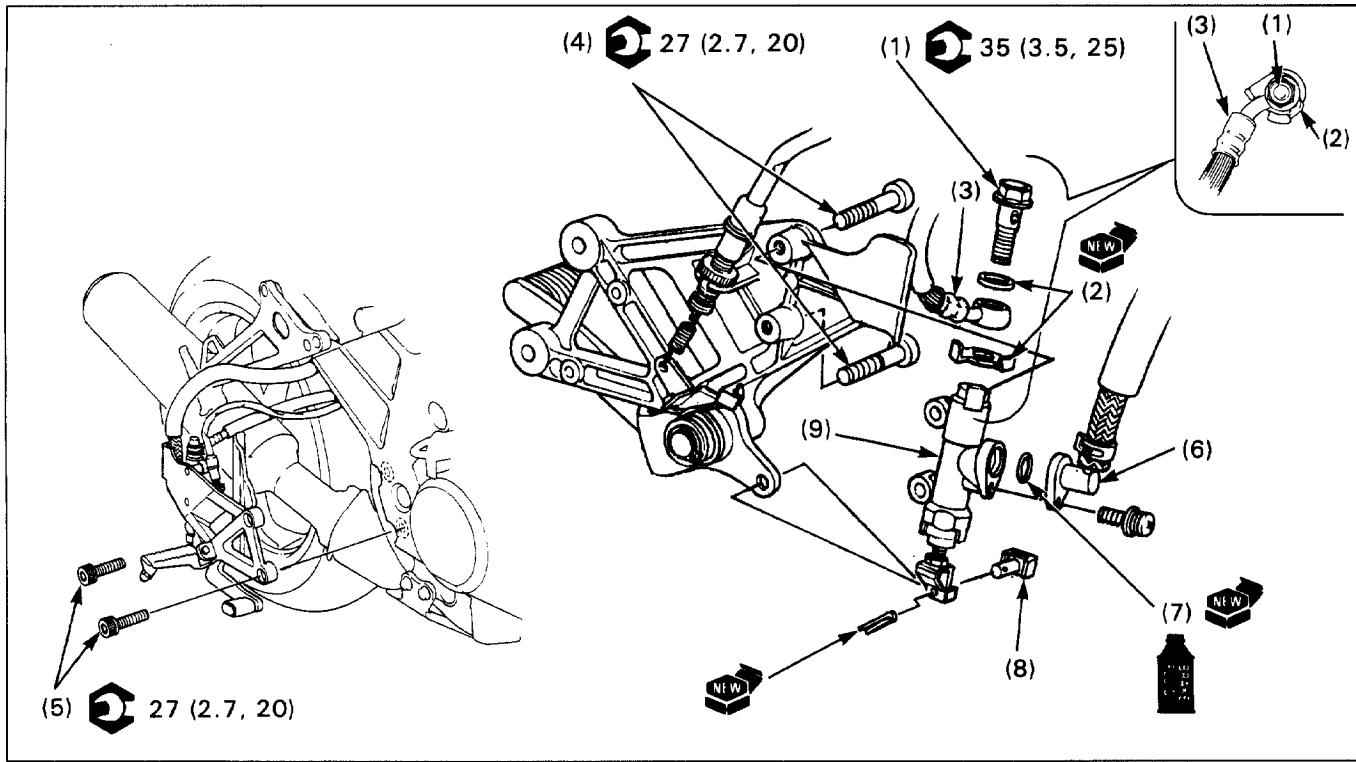

## Requisite Service

- Brake fluid replacement/air bleeding (section 17 of the Common Service Manual)

Procedure	Q'ty	Remarks
<b>Removal Order</b>		• Installation is in the reverse order of removal.
(1) Brake hose-bolt	1	Install the brake hose eyelet joint on the stopper as shown.
(2) Sealing washer	2	
(3) Brake hose	1	
(4) Master cylinder mounting bolt	2	
(5) Footpeg bracket bolt	2	
(6) Reservoir hose joint	1	
(7) O-ring	1	
(8) Push joint pin	1	
(9) Master cylinder assembly	1	

# Rear Master Cylinder Disassembly/Assembly

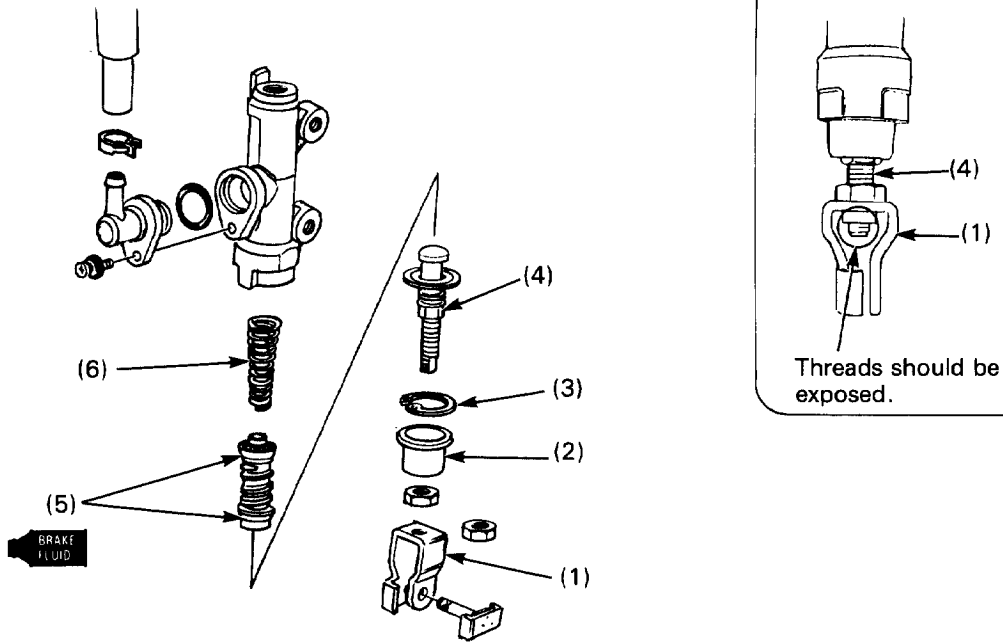

## NOTE

- Replace the master piston, spring, cups, snap ring and boot as a set.
- The master cylinder piston, cups and spring must be installed as a set.

## Requisite Service

- Brake fluid replacement/air bleeding (section 17 of the Common Service Manual)
- Rear master cylinder removal/installation (page 14-8)

Procedure	Q'ty	Remarks
<b>Disassembly Order</b>		
(1) Push rod joint	1	• Assembly is in the reverse order of disassembly. Install the joint so that the push rod's threads are exposed as shown.
(2) Boot	1	
(3) Snap ring	1	<b>NOTE:</b> • Install the snap ring with the chamfered side facing in. • Make sure the snap ring is fully seated in the groove.
(4) Push rod	1	Apply silicone grease to the rod head.
(5) Master piston assembly	1	
(6) Spring	1	Install it with its taper end toward the piston.

# Rear Brake Caliper Removal/Installation

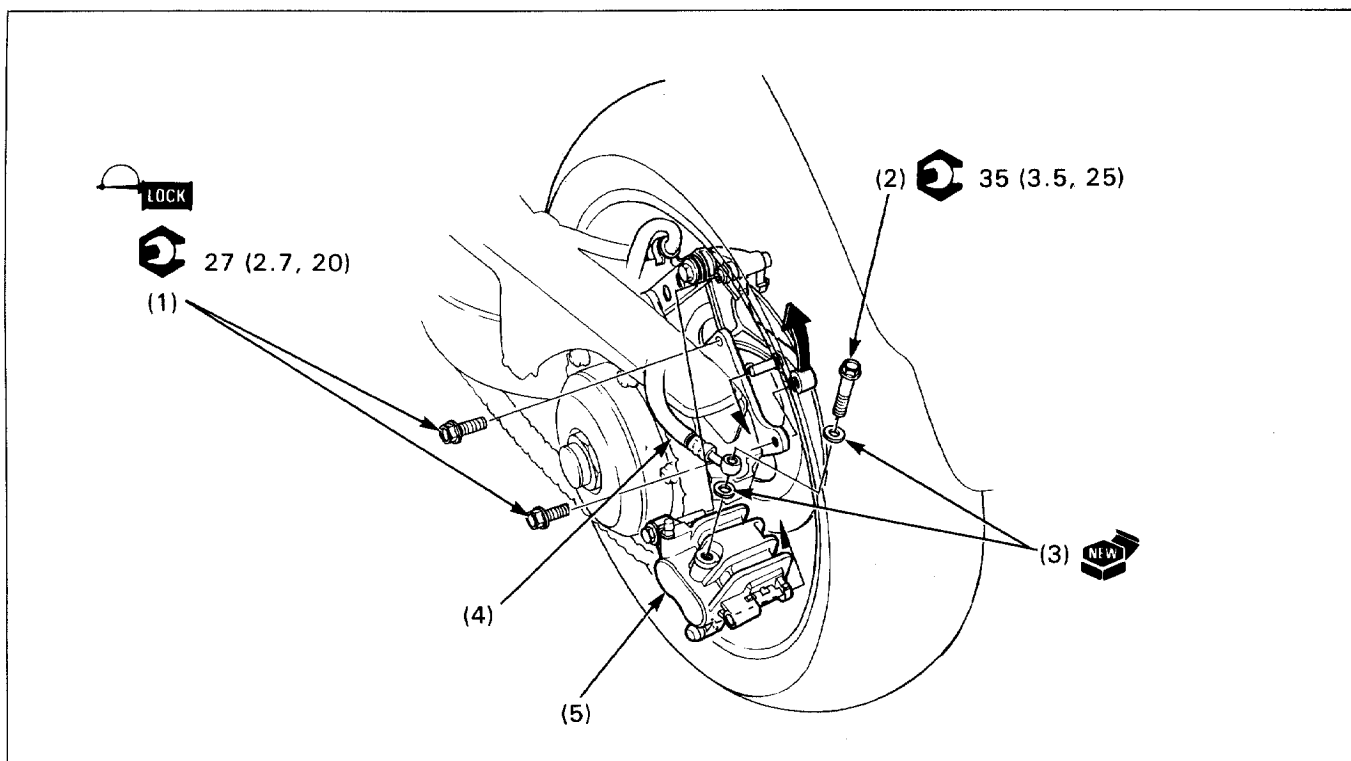

**WARNING**

- A contaminated brake disc or pad reduces stopping power. Discard contaminated pads and clean a contaminated disc with a high quality brake degreasing agent.
- Inhaled asbestos fibers have been found to cause respiratory disease and cancer. Never use an air hose or dry brush to clean brake assemblies. Use an OSHA-approved vacuum cleaner or alternate method approved by OSHA designed to minimize the hazard caused by airborne asbestos fibers.

**NOTE**

- Before disconnecting the brake hose (1), place a pan under the caliper to catch the draining fluid and squeeze the brake pedal slowly to push out the piston.

**Requisite Service**

- Brake pad removal/installation (page 14-3)
- Brake fluid replacement/air bleeding (section 17 of the Common Service Manual)

Procedure	Q'ty	Remarks
<b>Removal Order</b>		• Installation is in the reverse order of removal.
(1) Caliper bracket bolt	2	When installing, apply a locking agent to the threads.
(2) Brake hose bolt	1	
(3) Sealing washer	2	
(4) Brake hose	1	At installation, press the hose end against the stopper while tightening the hose bolt.
(5) Rear brake caliper assembly	1	

# Rear Brake Caliper Disassembly/Assembly

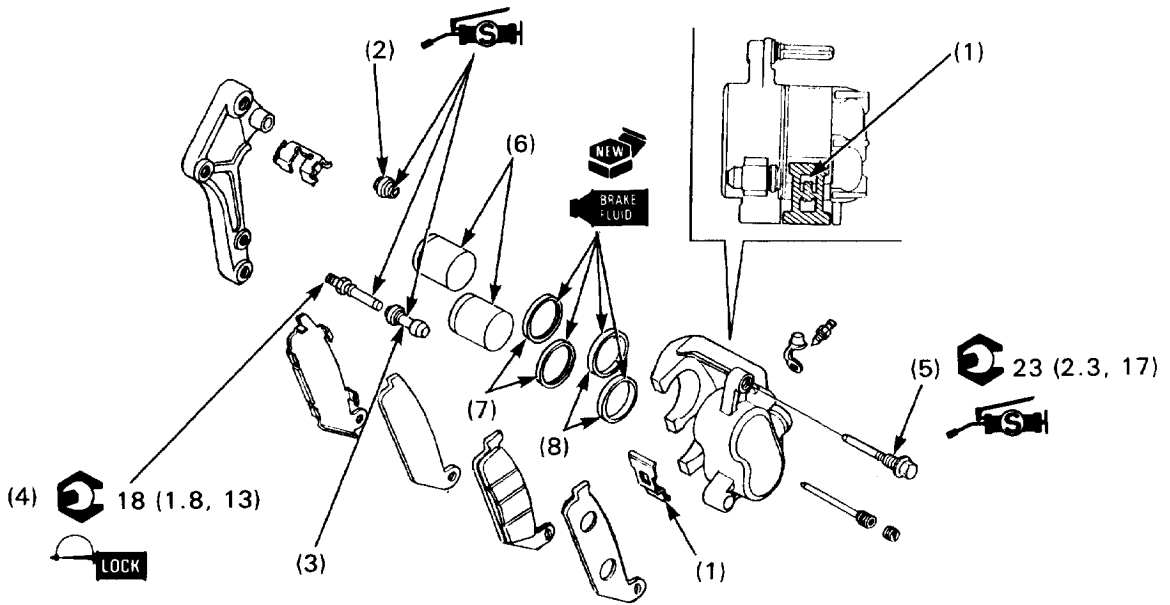

**WARNING**

- Inhaled asbestos fibers have been found to cause respiratory disease and cancer. Never use an air hose or dry brush to clean brake assemblies. Use an OSHA-approved vacuum cleaner or alternate method approved by OSHA designed to minimize the hazard caused by airborne asbestos fibers.

## Requisite Service

- Rear brake pad removal/installation (page 14-3)
- Brake fluid replacement/air bleeding (section 17 of the Common Service Manual)
- Rear brake caliper removal/installation (page 14-10)

Procedure	Q'ty	Remarks
<b>Disassembly Order</b>		• Assembly is in the reverse order of disassembly.
(1) Pad spring	1	
(2) Bracket pin boot	1	Install into the bracket groove securely.
(3) Caliper pin boot	1	
(4) Bracket pin bolt	1	When installing, apply a locking agent on threaded portion.
(5) Caliper pin bolt	1	
(6) Caliper piston	2	Install them with the opening toward the pad.
(7) Dust seal	2	<b>CAUTION</b> • Be careful not to damage the piston sliding surface when removing seals.
(8) Piston seal	2	

# Brake Pedal Removal/Installation

'90-'93:

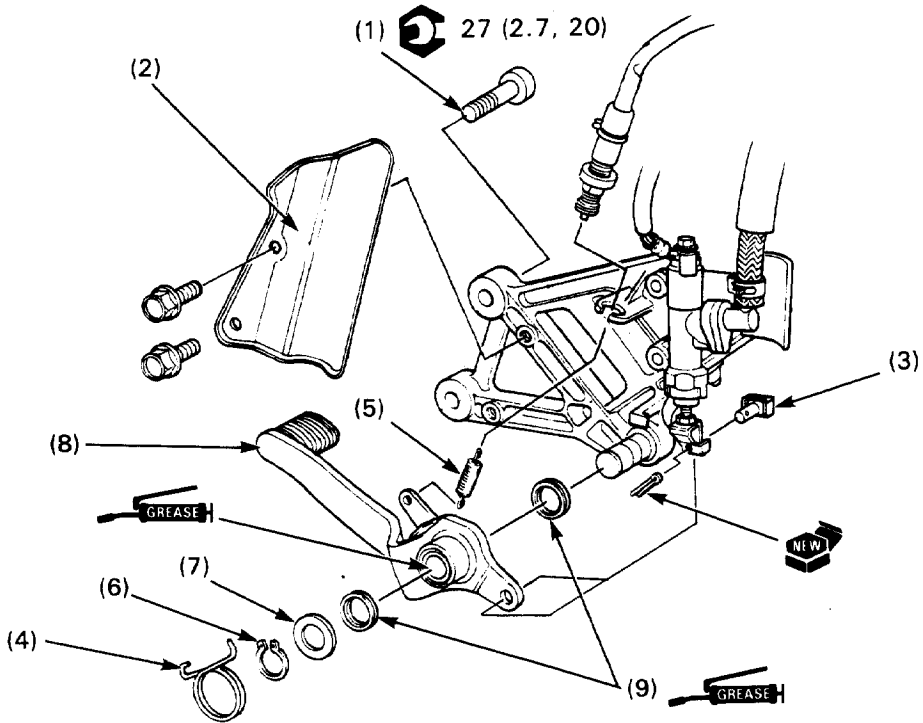

**NOTE**

- Adjust the brake pedal height after installation.

Procedure		Q'ty	Remarks
<b>Removal Order</b>			• Installation is in the reverse order of removal.
(1)	Footpeg stay bolt	2	
(2)	Heat guard	1	
(3)	Push rod joint pin	1	Put through push rod joint and brake pedal from the outside, then secure with a new cotter pin.
(4)	Brake pedal return spring	1	
(5)	Rear brake light switch spring	1	Be careful not to strain the spring too much during removal and installation.
(6)	Snap ring		<b>NOTE</b> • Install with the chamfered side facing brake pedal. • After installing, make sure it is fully seated in the groove.
(7)	Thrust washer	1	
(8)	Brake pedal	1	Apply grease to the brake pedal pivot.
(9)	Dust seal	2	

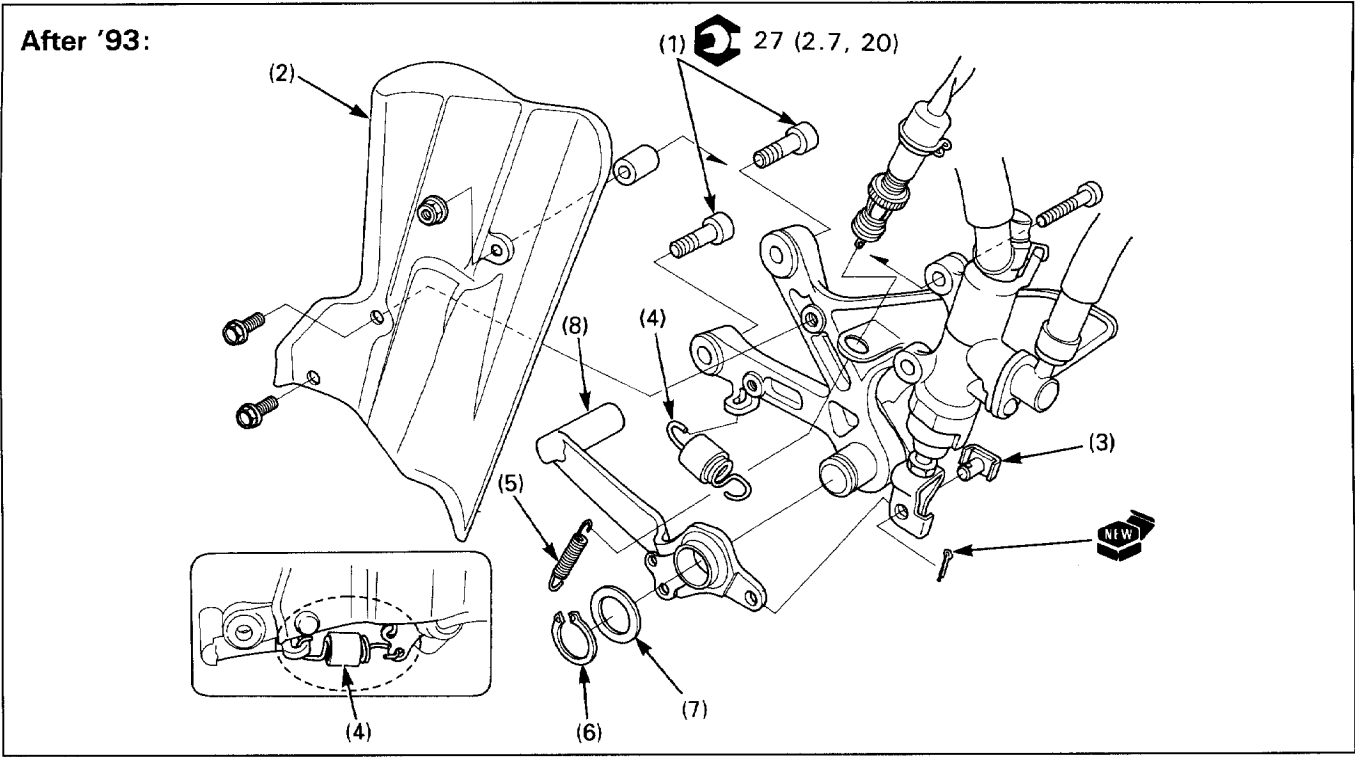

NOTE:

- The pedal height can be adjusted by turning the pedal joint on the master cylinder push rod.

Procedure	Q'ty	Remarks
<b>Removal Order</b>		Installation is in the reverse order of removal.
(1) Foot peg stay bolt	2	
(2) Heat guard	1	
(3) Push rod joint pin	1	Put through push rod joint and brake pedal from the out side, then secure with a new cotter pin.
(4) Brake pedal return spring	1	
(5) Rear brake light switch spring	1	Be careful not to strain too much during removal and installation.
(6) Snap ring	1	NOTE: • Install with the chamfered side facing brake pedal. • After installing, make sure it is fully seated in the groove.
(7) Thrust washer	1	
(8) Brake pedal	1	NOTE: • Do not lubricate to the pedal pivot.



# 15. Charging System/Alternator

Service Information	15-1	Charging System Inspection	15-5
System Location	15-2	Regulator/Rectifier	15-6
Circuit Diagram	15-2	Alternator Removal/Installation	15-7
Troubleshooting	15-3	Charging Coil Inspection	15-8
Battery Removal/Installation	15-4		

## Service Information

### ⚠ WARNING

- The battery gives off explosive gases; keep sparks, flames, and cigarettes away. Provide adequate ventilation when charging or using the battery in an enclosed space.
- The battery contains sulfuric acid (electrolyte). Contact with skin or eyes may cause severe burns. Wear protective clothing and a face shield.
  - If electrolyte gets on your skin, flush with water.
  - If electrolyte gets in your eyes, flush with water for at least 15 minutes and call a physician immediately.
- Electrolyte is poisonous. If swallowed, drink large quantities of water or milk and follow with milk of magnesia or vegetable oil and call a physician.
- **KEEP OUT OF REACH OF CHILDREN.**

- Always turn off the ignition switch before disconnecting any electrical component.

### CAUTION

- **Some electrical components may be damaged if terminals or connectors are connected or disconnected while the ignition switch is ON and current is present.**

- For extended storage, remove the battery, give it a full charge, and store it in a cool, dry place.
- For battery remaining in a stored motorcycle, disconnect the negative battery cable from the battery terminal.

### NOTE

- The maintenance free battery must be replaced when it reaches the end of its service life.

### CAUTION

- **The battery caps should not be removed. Attempting to remove the sealing caps from the cells may damage the battery.**

- For battery testing/charging, refer to section 22 of the Common Service Manual.
- The battery can be damaged if overcharged or undercharged, or if left to discharge for long periods. These same conditions contribute to shortening the "life span" of the battery. Even under normal use, the performance of the battery deteriorates after 2-3 years.
- Battery voltage may recover after battery charging, but under heavy load, battery voltage will drop quickly and eventually die out. For this reason, the charging system is often suspected to be the problem. Battery overcharge often results from problems in the battery itself, which may appear to be an overcharge symptom. If one of the battery cells is shorted and battery voltage does not increase, the regulator/rectifier supplies excess voltage to the battery. Under these conditions, the electrolyte level goes down quickly.
- Before troubleshooting the charging system, check for proper use and maintenance of the battery. Check if the battery is frequently under heavy load, such as having the headlight and taillight ON for long periods of time without riding the motorcycle.
- The battery will self-discharge when the motorcycle is not in use. For this reason, charge the battery every two weeks to prevent sulfation from forming.
- Filling a new battery with electrolyte will produce some voltage, but in order to achieve its maximum performance, always charge the battery. Also, the battery life is lengthened when it is initial-charged.
- When checking the charging system, always follow the steps in the troubleshooting flow chart (page 15-3).
- For charging system component locations, see page 15-2.

# System Location

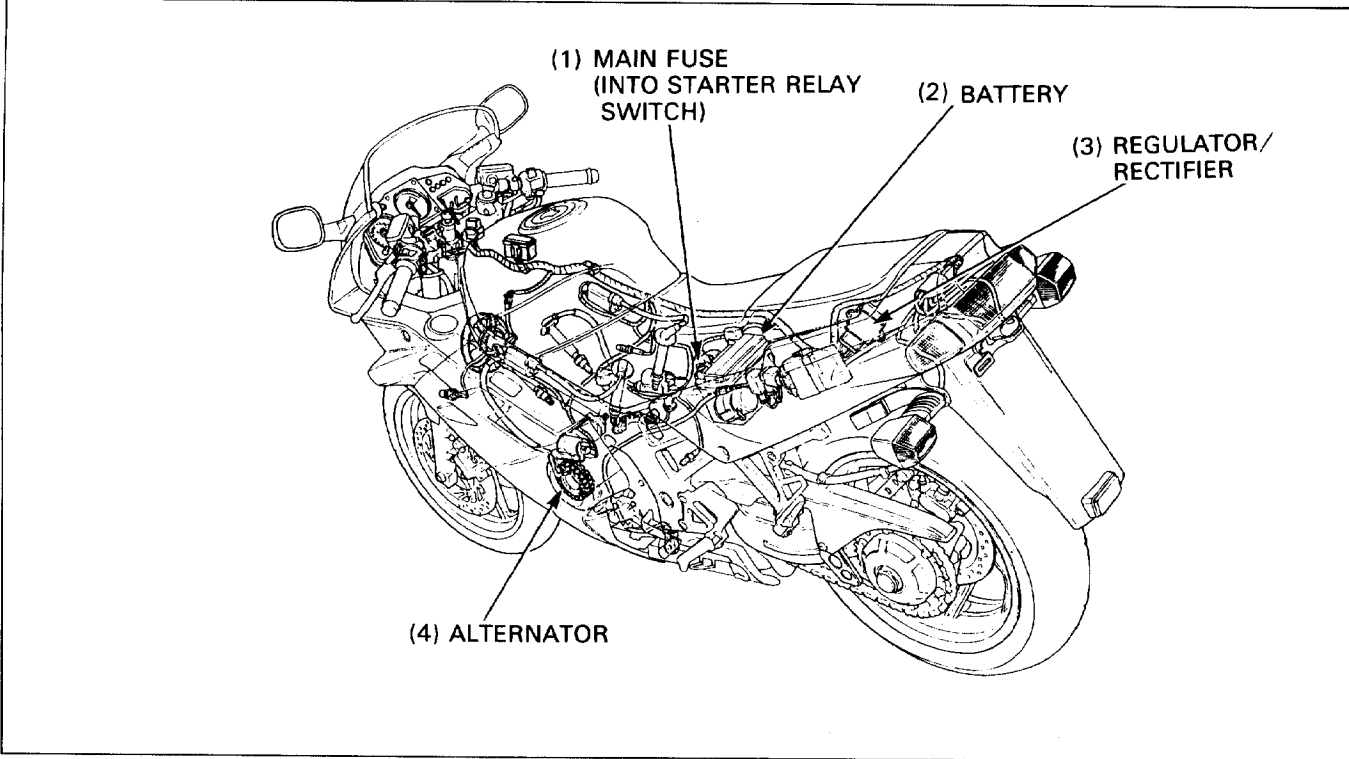

# Circuit Diagram

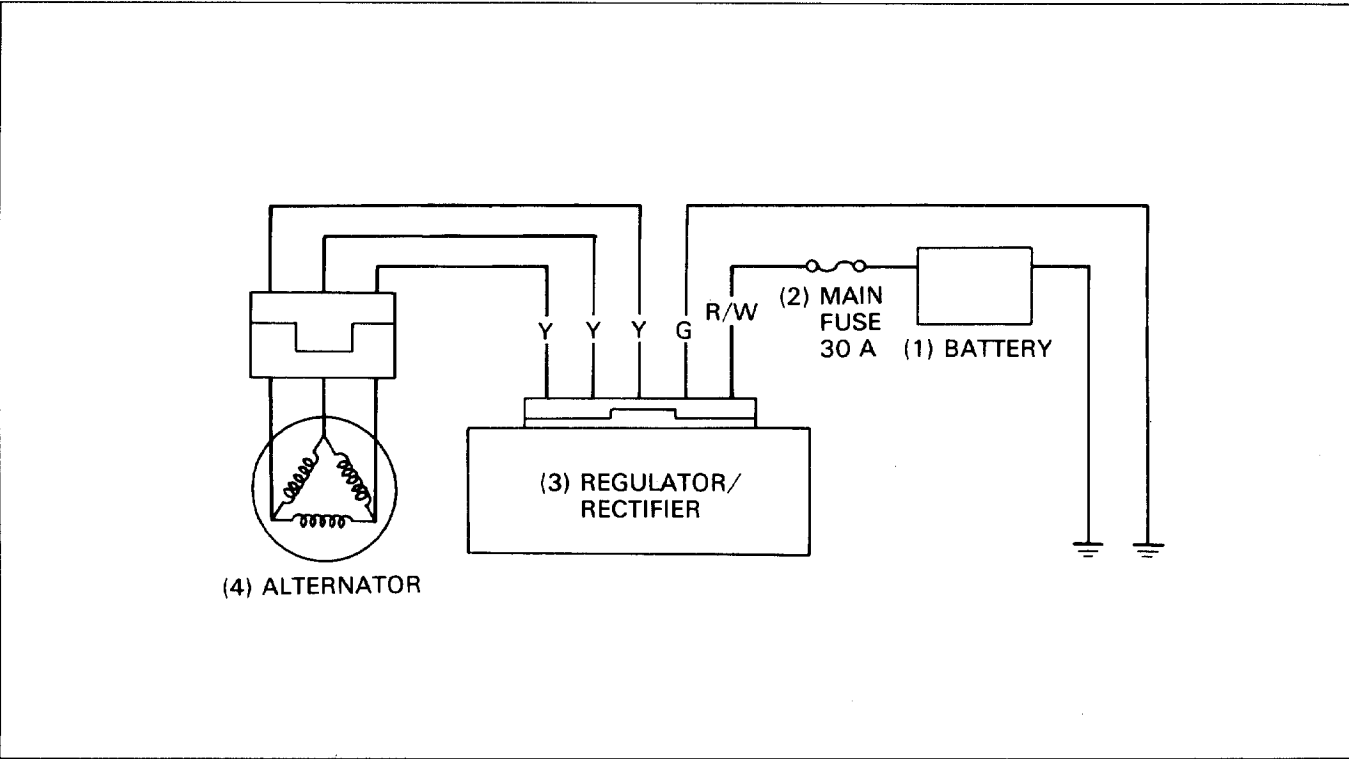

# Troubleshooting

## Battery overcharging

- Faulty regulator/rectifier

## Battery undercharging

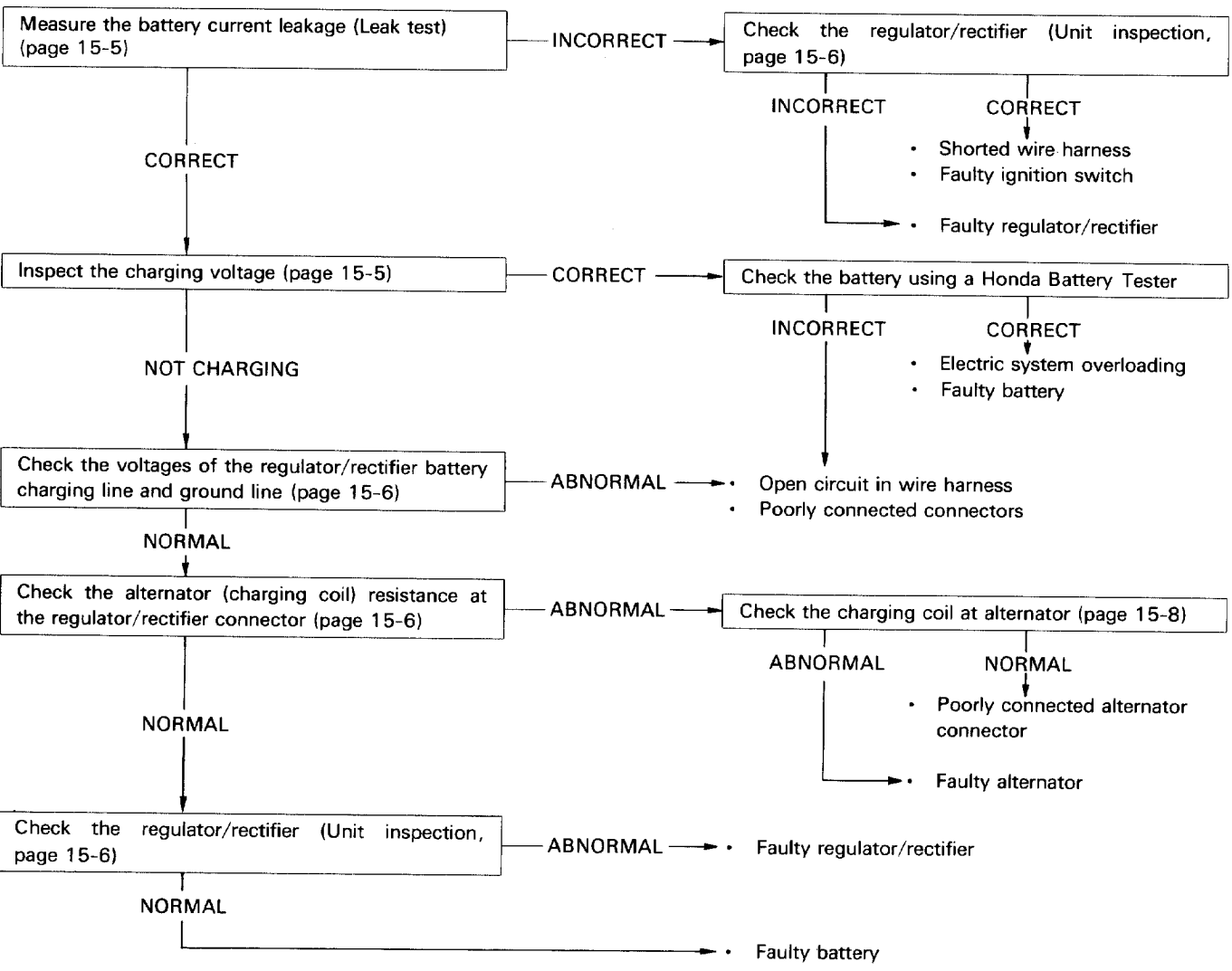

## Battery Removal/Installation

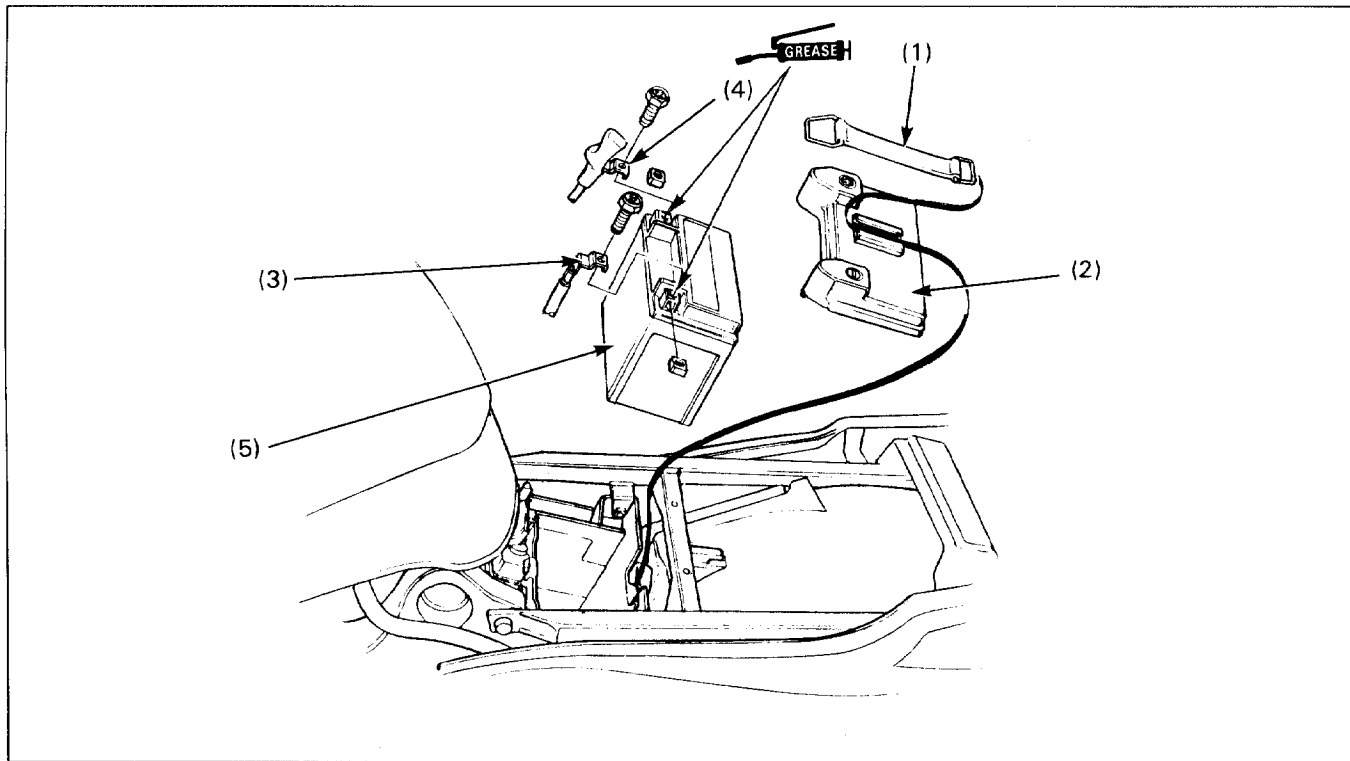

### ▲ WARNING

- Turn the ignition switch OFF.

### Requisite Service

- Seat removal/installation (page 2-2).

Procedure	Q'ty	Remarks
<b>Removal Order</b>		• Installation is in the reverse order of removal.
(1) Battery holder band	1	
(2) Battery cover	1	'90-'93 only
(3) Negative (-) terminal	1	Remove the bolt and disconnect the terminal.
(4) Positive (+) terminal	1	At installation, connect the terminal first, and apply grease to it.
(5) Battery	1	

# Charging System Inspection

## Leak Test

Turn off the ignition switch, and disconnect the ground (-) cable from the battery.

Connect the ammeter (+) probe to the ground cable and the ammeter (-) probe to the battery (-) terminal.

With the ignition switch off, measure the leakage current.

### NOTE

- When measuring current using a tester, set it to a high range, and then bring the range down to an appropriate level. Current flow larger than the range selected may blow out the fuse in the tester.
- While measuring current, do not turn the ignition on. A sudden surge of current may blow out the fuse in the tester.

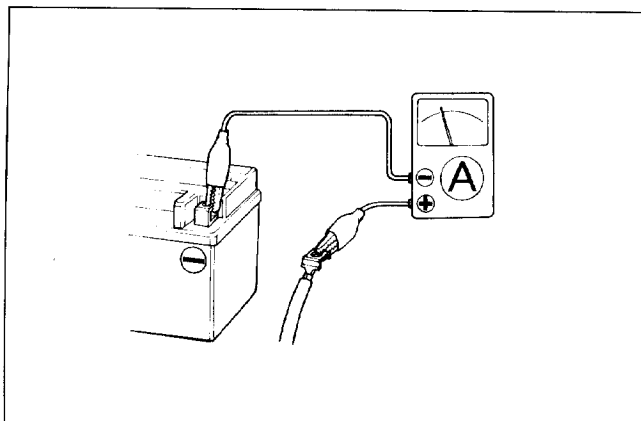

## Specified Current Leakage: 1.2mA max.

If current leakage exceeds the specified value, a shorted circuit is likely.

Locate the short by disconnecting connections one by one and measuring the current.

## Charging Voltage Inspection

### NOTE

- Before performing this test, be sure that the battery is fully charged and that the voltage between its terminals is greater than 12.8V.

Start the engine and warm it up to operating temperature, then turn the ignition switch OFF.

Connect a multimeter between the battery terminals.

### 5 TOOL

#### Digital multimeter

KS-AMH-32-003  
(U.S.A. only)

Disconnect the starter relay switch connector and remove the main fuse (30 A). Reconnect the connector onto the relay switch.

Connect the ammeter as shown.

### CAUTION

- Be careful not to short any tester probes.
- Although the current could be measured when the ammeter is connected between the battery positive terminal and the positive cable, a sudden surge of current to the starter motor could damage the ammeter.
- Always turn the ignition off when conducting the test. Disconnecting the ammeter or wires when current is flowing may damage the ammeter.

Start the engine and increase the engine speed gradually.

**Regulated Voltage: 13.5-16.0V/5,000rpm**

**Charging Current: 5-9A/5,000rpm**

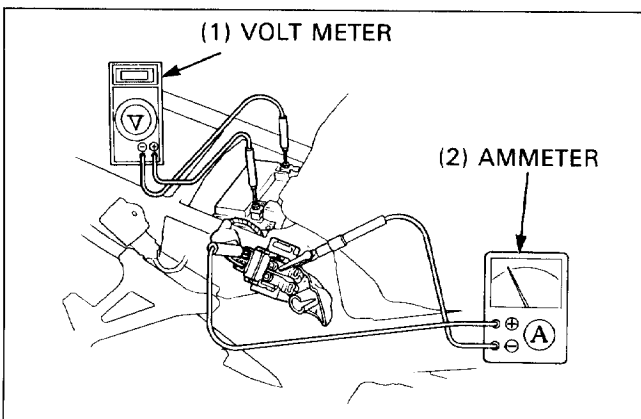
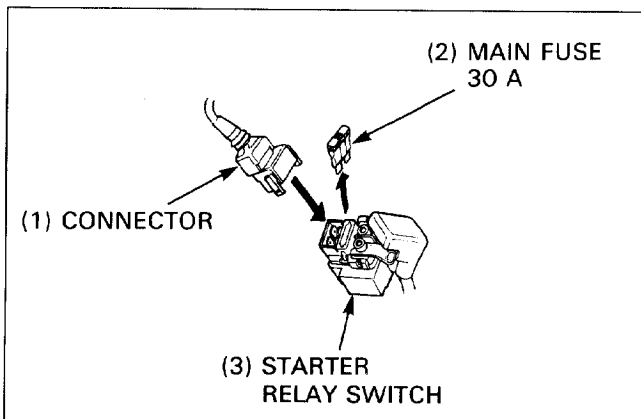

# Regulator/Rectifier

## Wire Harness Inspection

Remove the seat (page 2-2) and rear fairing (page 2-3).

Disconnect the regulator/rectifier connector and measure the following between connector terminals of the wire harness side.

Item	Terminals	Specification
Battery charging line	Red/White (+) and ground (-)	Battery voltage should register.
Ground line	Green and ground	Continuity.
Charging coil line	Yellow and Yellow	1.0-2.0Ω (20°C/68°F)

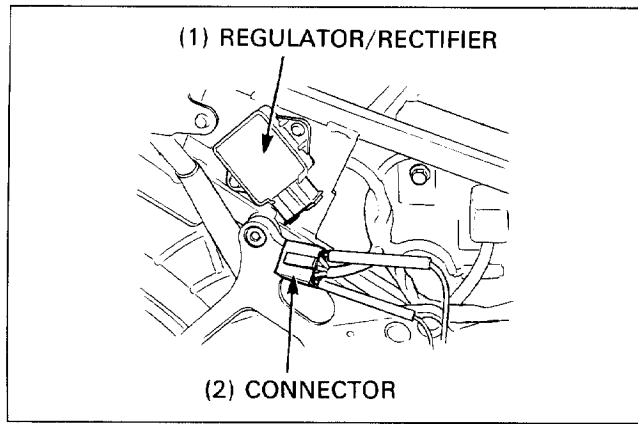

## Unit Inspection

Remove two bolts and regulator/rectifier.

Inspect the regulator/rectifier unit by measuring the resistance between the terminals. (Refer to the chart at the bottom of this page.)

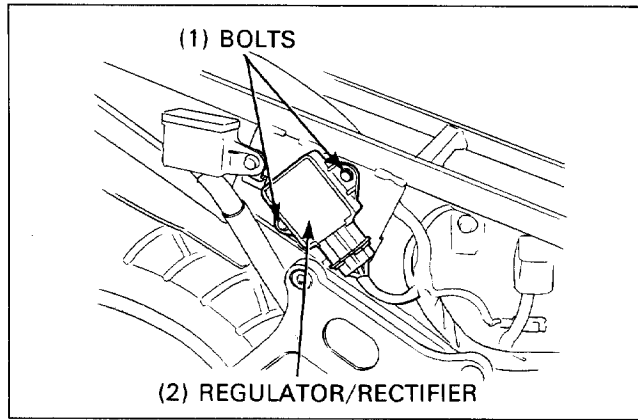

### NOTE

- Resistance value will not be accurate if the probes touch your finger.
- Use the following recommended multimeter. Using another manufacturer's equipment may not allow you to obtain the specified values. This is due to the characteristic of semiconductors, which have different resistance value depending on the applied voltage.

#### Specific Multimeters:

- KS-AMH-32-003 (U.S.A. only: Digital type)
- 07308-0020001 (SANWA Analogue type)
- TH-5H (KOWA Analogue type)

- Select the following range.

**SANWA tester:** ×kΩ  
**KOWA tester:** ×100Ω

- When using the KOWA multimeter, remember that all readings should be multiplied by 100.
- An old, weak multimeter battery could cause inaccurate readings. Check the battery if the multimeter registers incorrectly.

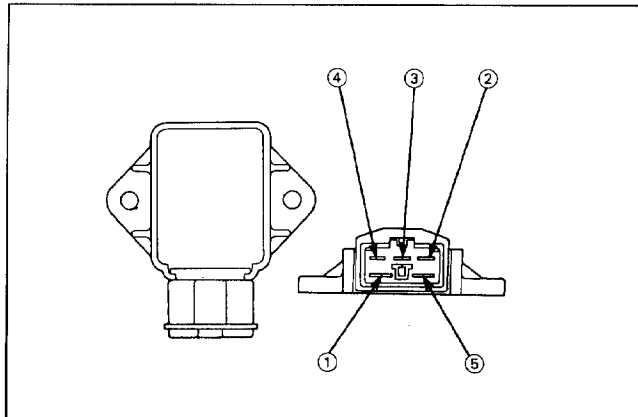

Replace the regulator/rectifier unit if the resistance value between the terminals is abnormal.

Install the regulator/rectifier in the reverse order of removal.

Unit: kΩ

	+	①	②	③	④	⑤
①	-		∞	∞	∞	∞
②		0.5-10		∞	∞	∞
③		0.5-10	∞		∞	∞
④		0.5-10	∞	∞		∞
⑤		0.7-15	0.5-10	0.5-10	0.5-10	

# Alternator Removal/Installation

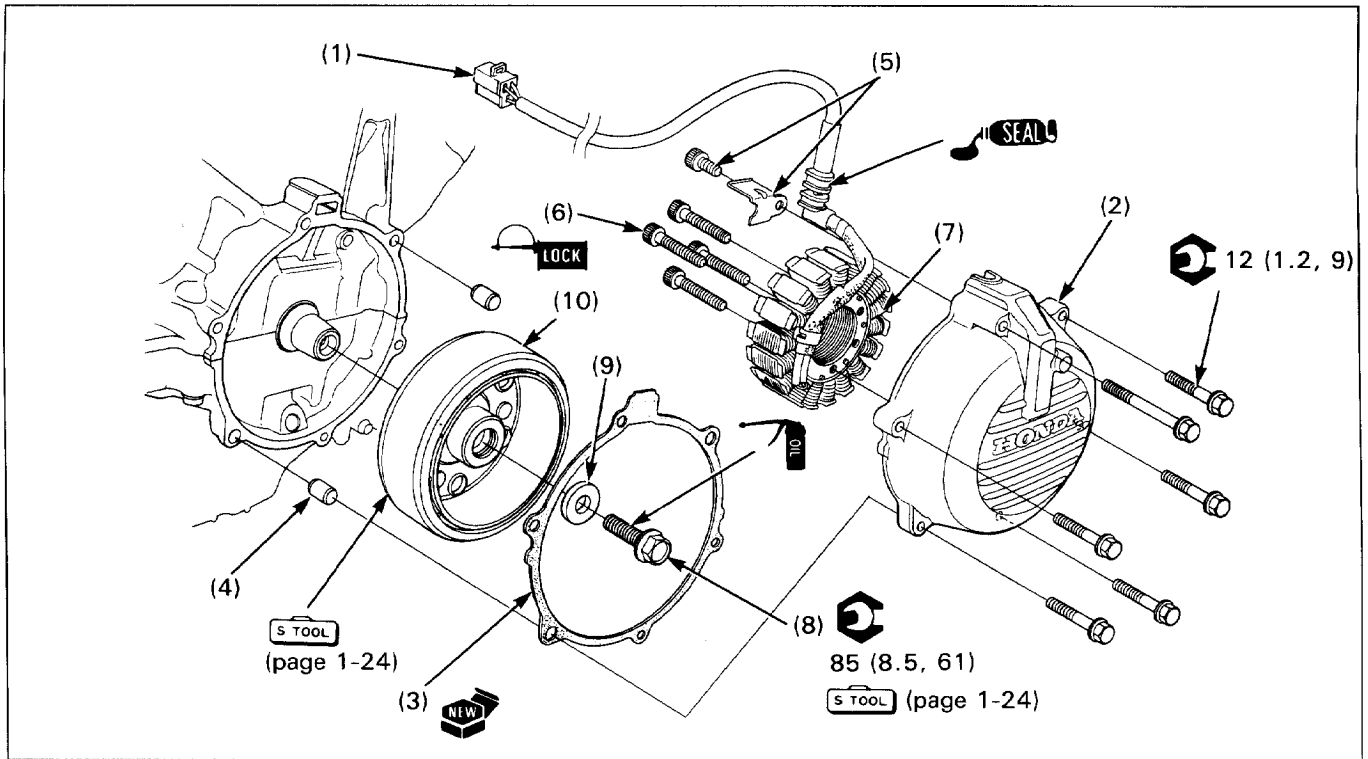

## Requisite Service

- Middle fairing removal/installation (page 2-4).
- Lower fairing removal/installation (page 2-7).

Procedure	Q'ty	Remarks
<b>Removal Order</b>		• Installation is in the reverse order of removal.
(1) Alternator wire	1	Disconnect the connector.
(2) Alternator cover	1	
(3) Gasket	1	
(4) Dowel pin	2	
(5) Alternator wire bolt/clamp	1	After installation, make sure that wire is not pinched by the flywheel.
(6) Stator mounting bolt	4	Apply a locking agent to the threads.
(7) Stator	1	
(8) Flywheel bolt	1	NOTE Before installing, clean the engine oil completely off the contact surfaces of the crankshaft and flywheel.
(9) Washer	1	
(10) Flywheel	1	

## Charging Coil Inspection

### NOTE

- It is not necessary to remove the alternator from the engine.

Disconnect the alternator 3P connector and measure the resistance between connector terminals (Yellow and Yellow).

**Standard: 0.1-1.0 $\Omega$  (20°C/68°F)**

Check for continuity between the Yellow wire terminal and ground. There should be no continuity.

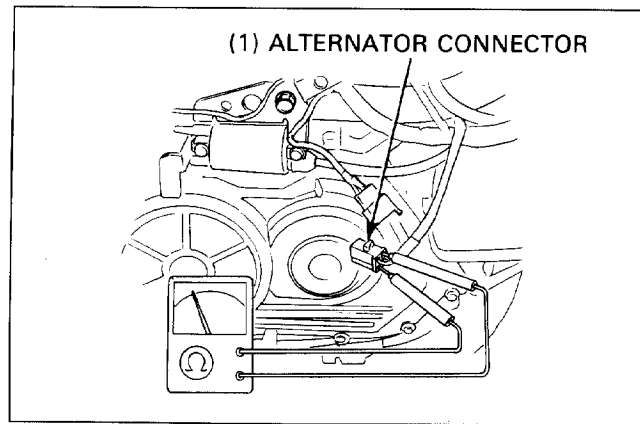

# 16. Ignition System

<b>Service Information</b>	<b>16-1</b>	<b>Ignition Pulse Generator</b>	<b>16-7</b>
<b>System Location</b>	<b>16-2</b>	<b>Ignition Timing</b>	<b>16-7</b>
<b>Circuit Diagram</b>	<b>16-2</b>	<b>Ignition Coil Removal/Installation (After '93)</b>	<b>16-8</b>
<b>Troubleshooting</b>	<b>16-3</b>	<b>Ignition Pulse Generator Removal/Installation</b>	<b>16-10</b>
<b>Ignition coil</b>	<b>16-6</b>		

## Service Information

- When checking the ignition system, always follow the steps in the troubleshooting flow chart (page 16-3).
- Perform the spark test at each cylinder before troubleshooting.
- A loose connection is often the cause of ignition problems. Check all connections before troubleshooting.
- Make sure the battery is adequately charged. Using the starter motor with a weak battery results in a slower engine cranking speed as well as a weak spark at the plugs.
- This ignition system has the ignition cut-off side stand (switch). The system should operate whenever:
  - the side stand is retracted
  - The transmission is in neutral
- For side stand inhibitor system instructions, see page 16-5 "NOTE" of the troubleshooting.
- The transistorized ignition system use an electrically controlled ignition timing system. No adjustments can be made to the ignition timing.
- A rough diagnosis can be made by identifying the cylinder whose spark timing is incorrect.
- Use spark plugs of the correct heat range. Using spark plugs with an incorrect heat range can damage the engine. Refer to section 2 of the Common Service Manual.
- For neutral switch inspection, see page 18-15; for switch location, see page 16-2 of this manual (SYSTEM LOCATION).
- For the ignition switch and engine stop switch inspection, check for continuity on the continuity chart of the WIRING DIAGRAM, section 19. Disconnect each switch connector behind the instruments (page 1-29) and check it.

# System Location

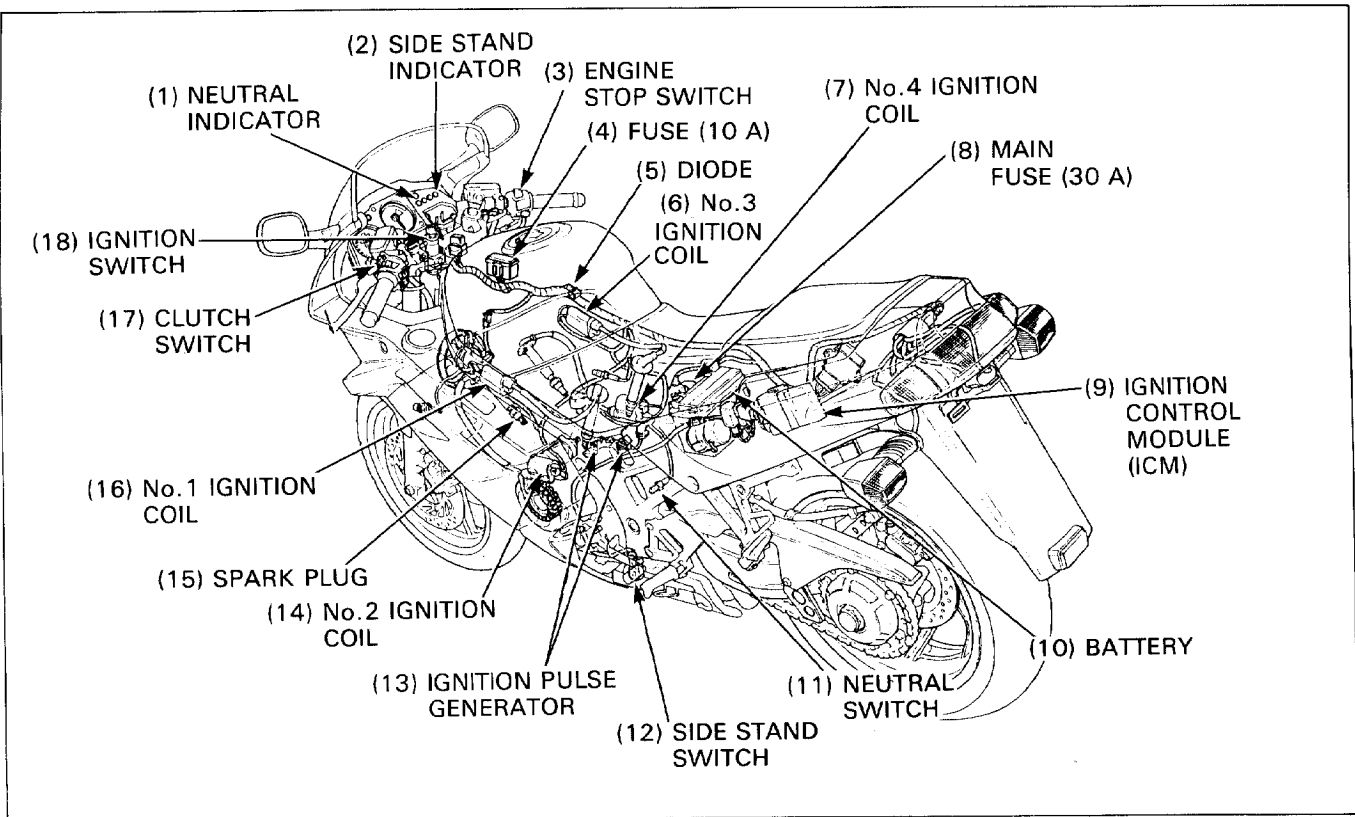

# Circuit Diagram

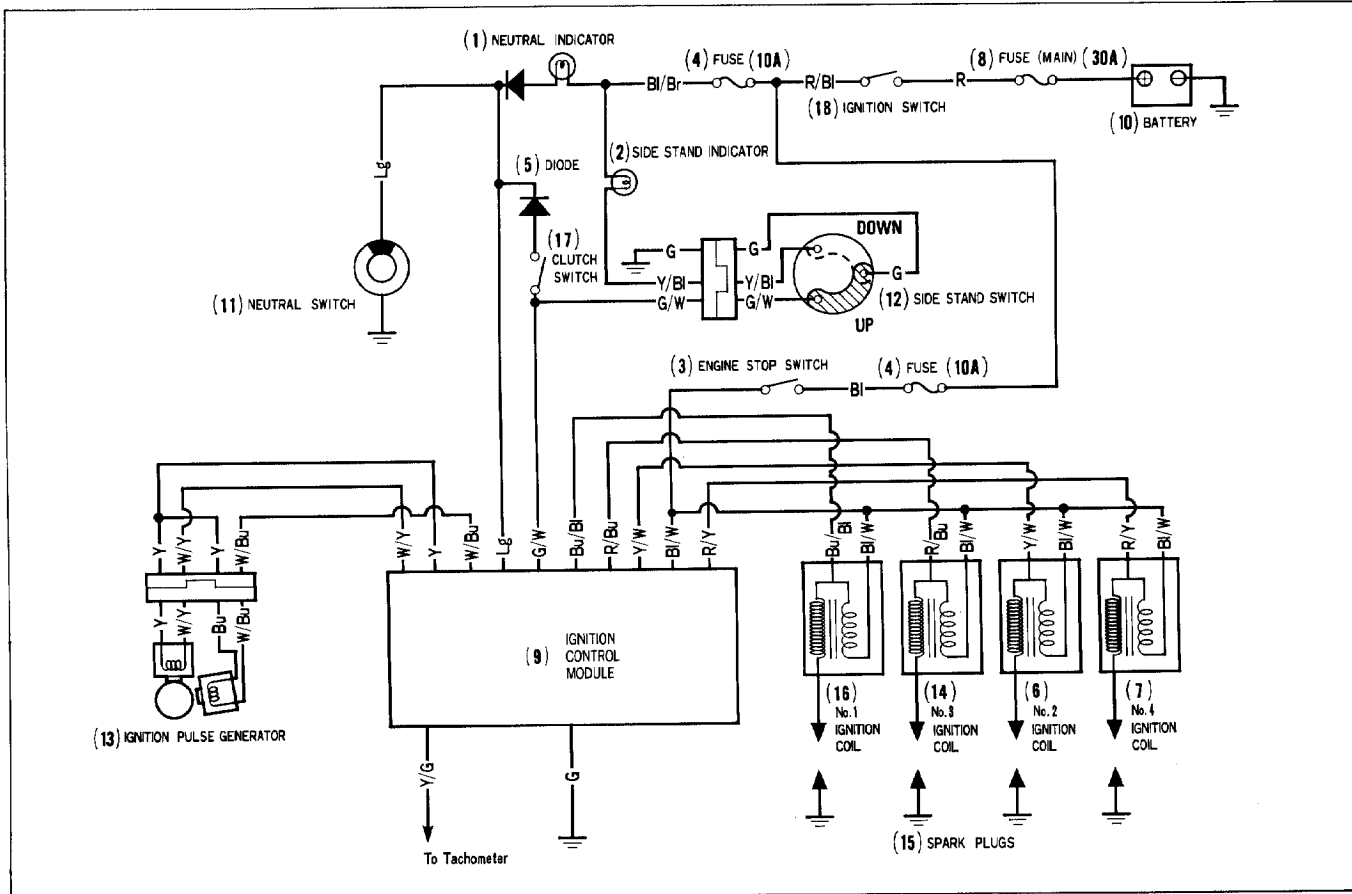

# Troubleshooting

## No spark at all plugs (Faulty input system)

- If there is no spark at all plugs, the problem could be at the input of the ignition system (ignition pulse generator, power input circuit of the ignition control module (ICM), neutral switch, side stand switch or ICM).

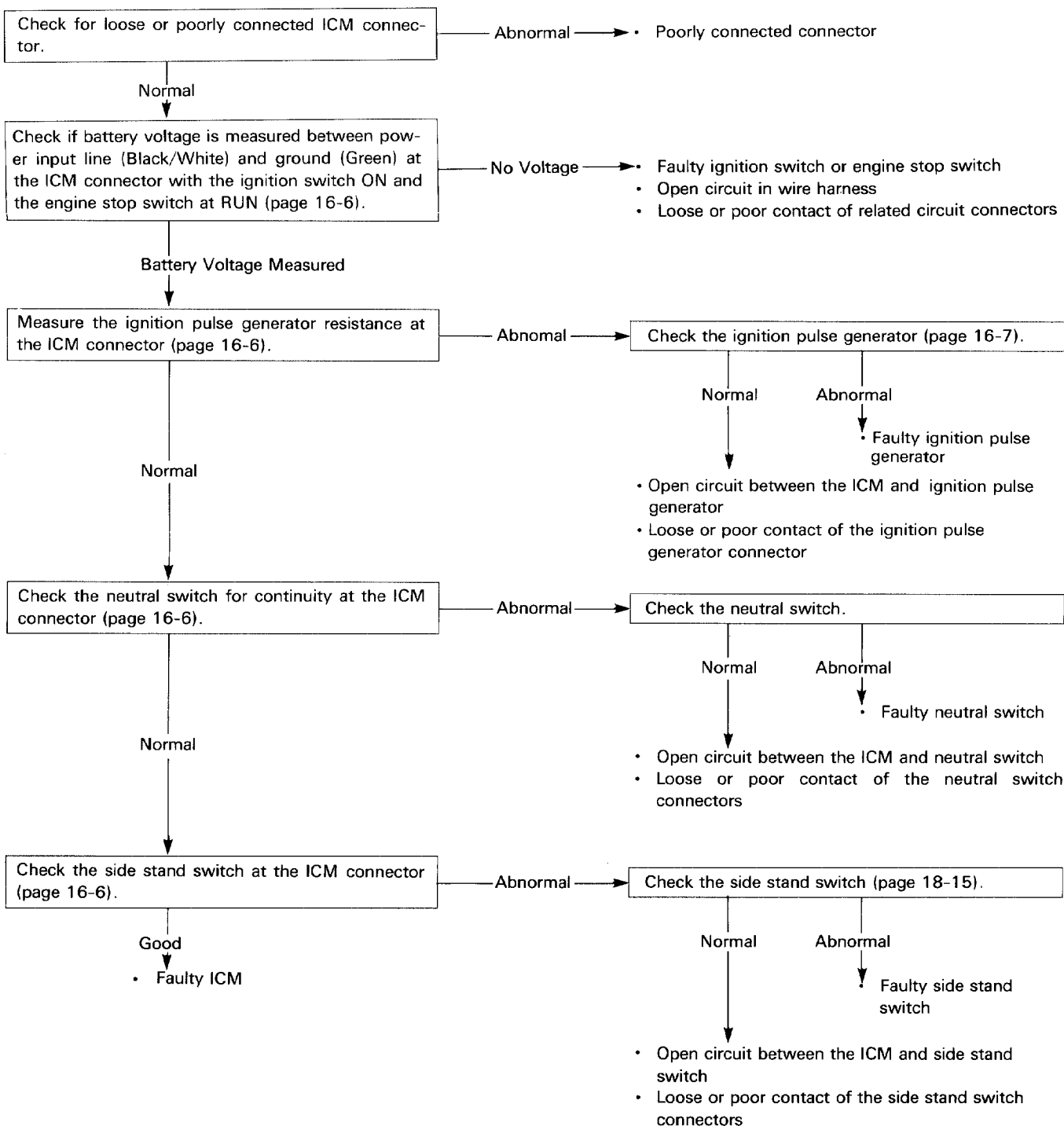

# Ignition System

## No spark at either ignition group (No. 1/3 cylinder and No. 2/4 cylinder)

• If there is no spark at either group, the problem is suspected in the primary coil side of the ignition system (ignition coil, or ignition control module (ICM) and ignition coil circuit).

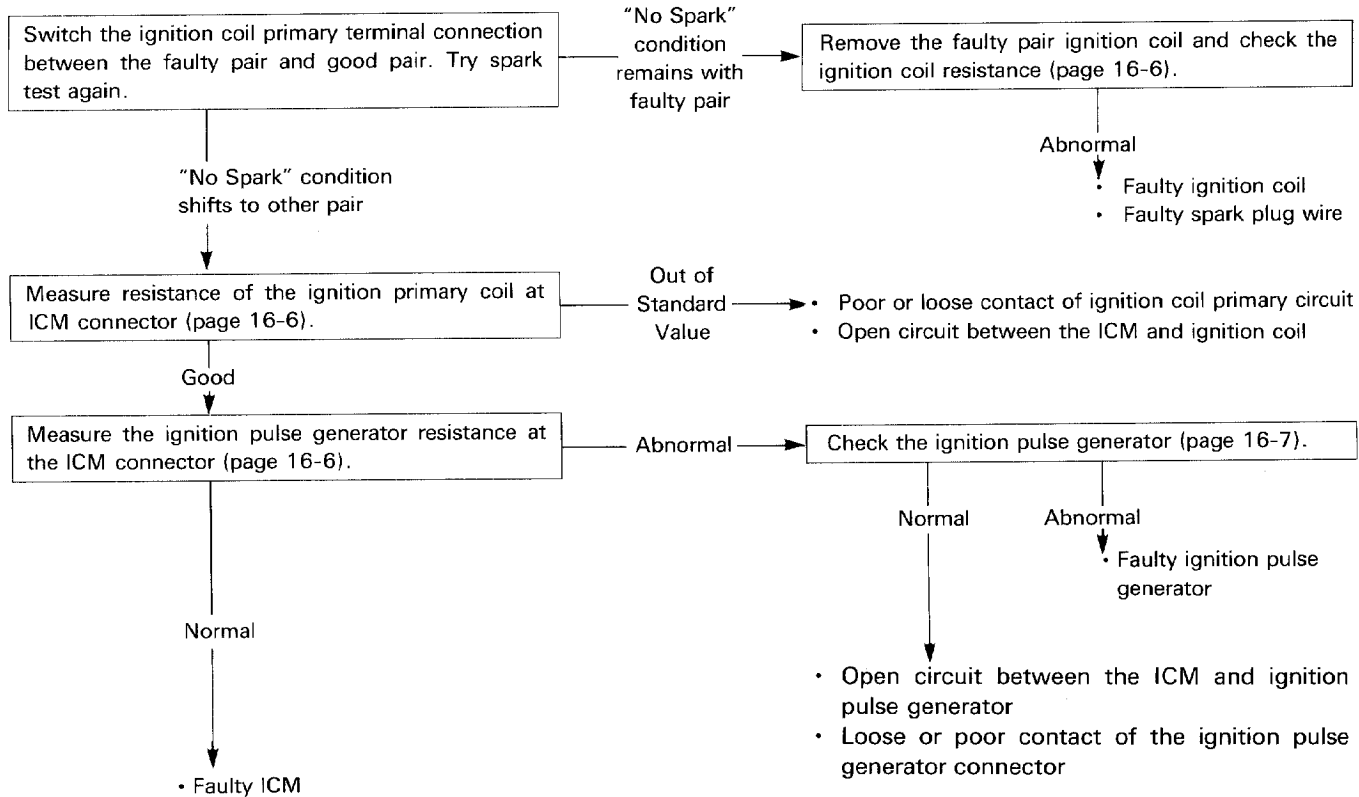

## No spark at one plug (Trouble in secondary coil side)

• Faulty spark plug is most likely.

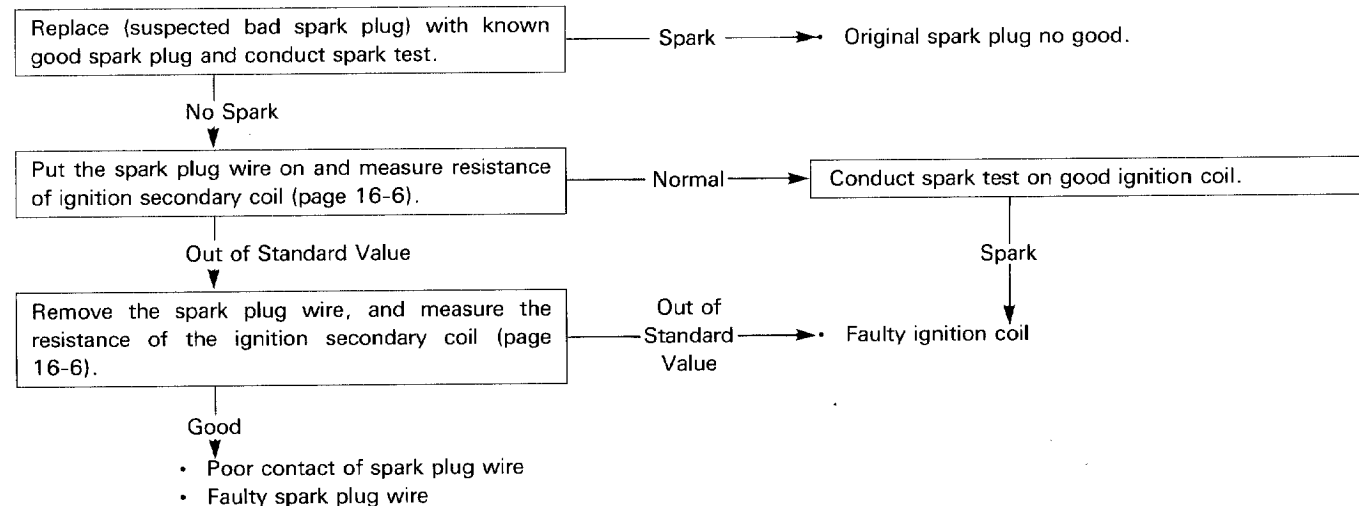

Engine starts, but side stand switch does not function at all.

NOTE

The side stand switch should function as follows:

- When the transmission is shifted into a gear from neutral with the side stand down, the ignition shuts off and the engine will stop.
- When in neutral switch line (a) of the ignition control module (ICM) is connected to ground via the neutral switch. When the side stand is up, the side stand switch line (b) of the ICM passes to ground via the side stand switch. The ICM monitors lines (a) and (b), and provides spark only when one or both of those lines is connected to ground via the neutral switch or the side stand switch.

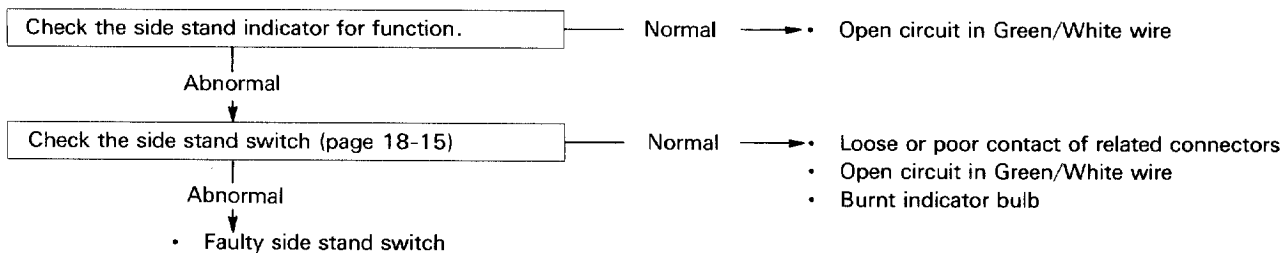

# Ignition System Inspection

## Circuit Inspection

Remove the rear fairing (page 2-3).  
 Disconnect the ignition control module (ICM) connectors and check them for loose or corroded terminals.  
 Measure the data between the connector terminals using the following chart.

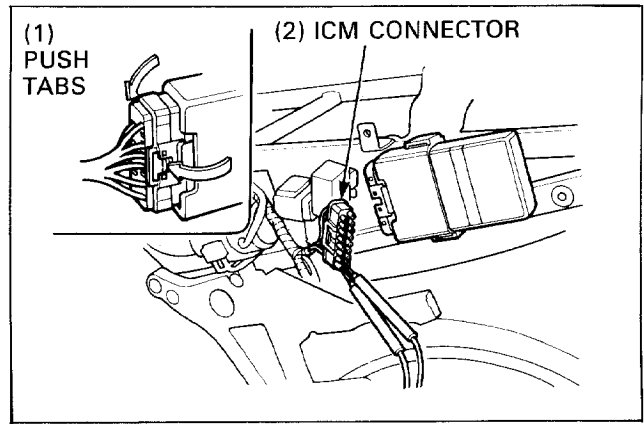

Item	Terminals	Specification
Power source input line	Black/White (+) and ground (-)	Battery voltage should register with the ignition switch ON and the engine stop switch at RUN.
Ignition pulse generator coil (Inspection page 16-7)	Yellow and White/Yellow Yellow and White/Bule	450–550Ω (20°C/68°F)
Ignition primary coil (Inspection below)	No. 1: Black/White and Bu/Bl No. 2: Black/White and Y/W No. 3: Black/White and R/Bu No. 4: Black/White and R/Y	2–4Ω (20°C/68°F)
Neutral switch line (Switch inspection: page 18-5)	Light Green and ground	Continuity in neutral No continuity in any gear (except neutral).
Side stand switch line (Switch inspection: page 18-9)	Green/White and ground	Continuity with the side stand up. No continuity with the side stand down.
Ground line	Green and ground	Continuity

## Ignition Coil

### Inspection

Remove the middle fairing (page 2-4).  
 Measure each primary coil resistance at the terminals.  
**Standard: 2-4Ω (20°C/68°F)**

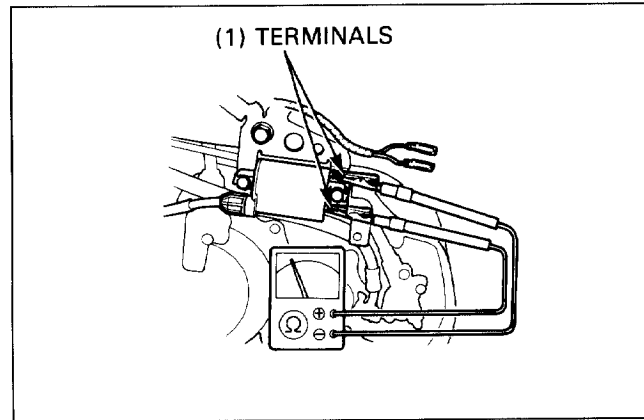

Disconnect the spark plug caps from the plugs and measure the secondary coil resistance with the spark plug caps in place.

**Standard: 17–24 kΩ (20°C/68°F)**

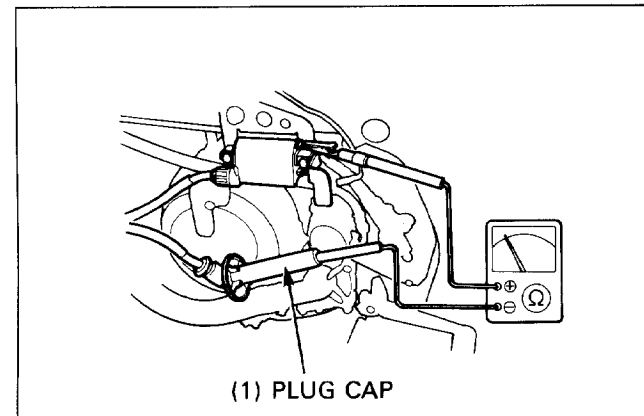

If the resistance is out of range, remove the spark plug caps and measure the resistance between the secondary coil terminals.

**Standard:** 13–17 kΩ (20°C/68°F)

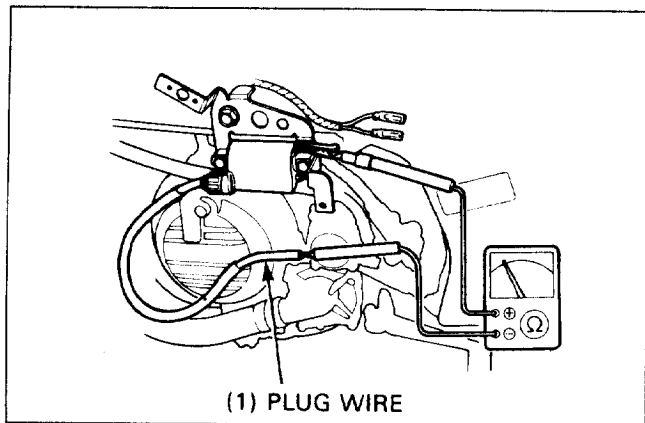

## Ignition Pulse Generator

### Inspection

#### NOTE

- It is not necessary to remove the ignition pulse generator from the engine.

Disconnect the ignition pulse generator 4P mini black connector and measure the resistance between White/Yellow-Yellow and Yellow-White/Blue terminals.

**Standard:** 200-400Ω (20°C/68°F)

For replacement of the ignition pulse generator, refer to page 16-10.

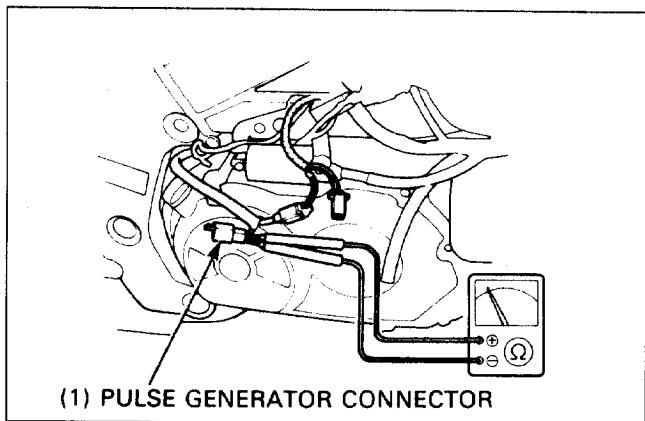

## Ignition Timing

Warm up the engine.

Stop the engine and connect a timing light to the No. 1 cylinder spark plug wire.

#### NOTE

- Read the instructions for timing light operation.

#### Remove the following:

- Lower fairing (page 2-7)
- Timing hole cap

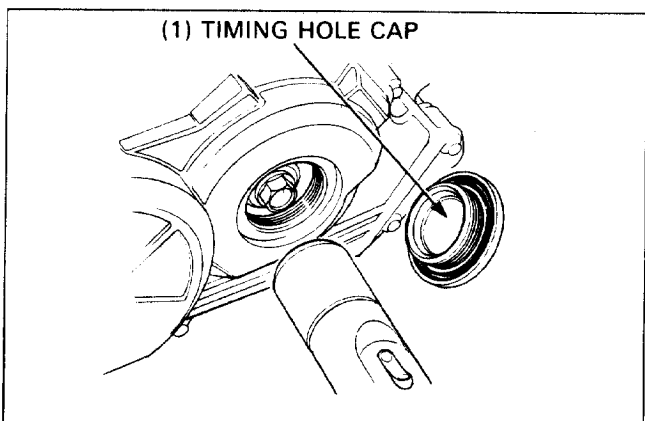

Start the engine and let it idle.

The timing is correct if the F mark aligns with the crankcase cover index mark.

Increase the engine speed by rotating the throttle stop screw on the carburetor, make sure the F mark begins to move counterclockwise at approximately 2,000 rpm.

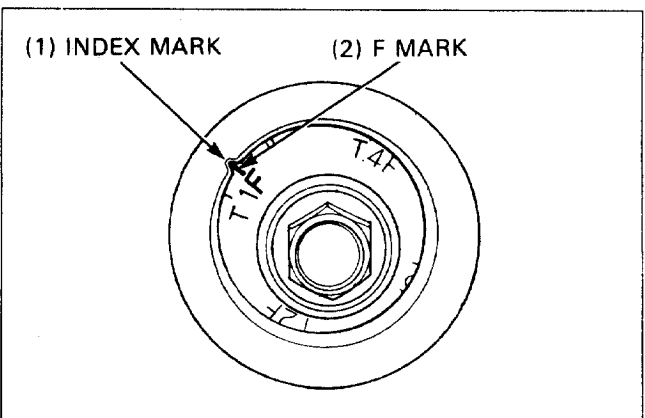

# Ignition Coil Removal/Installation (After '93)

## No.2/No.4 Ignition Coil (Front):

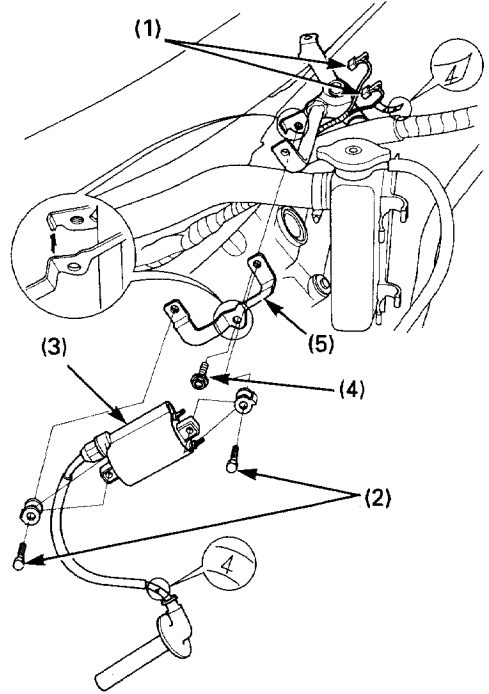
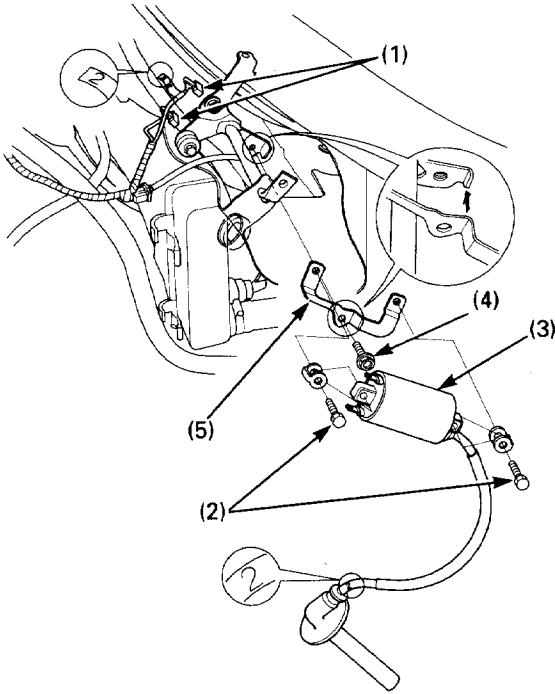

**NOTE**

- The cylinder numbers are printed on each spark plug wire. Be sure to install each spark plug caps on the correct cylinder.

**Requisite Service**

- Spark plug cap removal/installation (page 3-7)
- Upper fairing removal/installation (page 2-12)

Procedure		Q'ty	Remarks
(1)	<b>Removal Order</b> Connector	4	Installation is in the reverse order of removal. Connect the cylinder numbered wires to the green colored terminals.  At installation, align the edge of the stay with the tab of the frame.
(2)	Bolt	4	
(3)	Ignition coil	2	
(4)	Bolt	2	
(5)	Stay	2	

**No.1/No.3 Ignition Coil (Rear):**

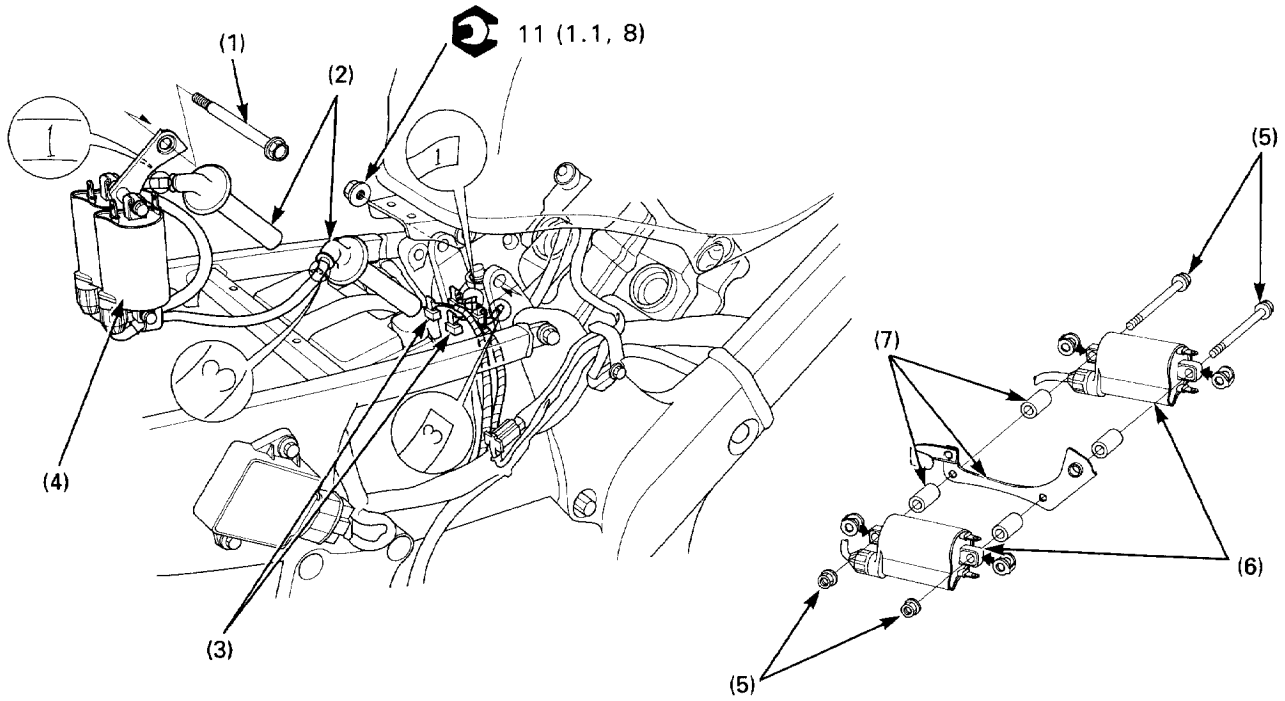

**Requisite Service**

- Rear fairing removal/installation (page 2-3)

Procedure		Q'ty	Remarks
<b>Removal Order</b>			Installation is in the reverse order of removal.
(1)	Fuel tank mounting bolt	1	Raise the rear side of the fuel tank and remove the caps. Connect the cylinder numbered wires to the green colored terminals. <b>NOTE:</b> • Remove the ignition coil assembly out of the frame to the upward.
(2)	Spark plug cap	2	
(3)	Connector	4	
(4)	Ignition coil assembly	1	
(5)	Bolt/nut	2/2	
(6)	Ignition coil	2	
(7)	Stay/collar	1/4	

# Ignition Pulse Generator Removal/Installation

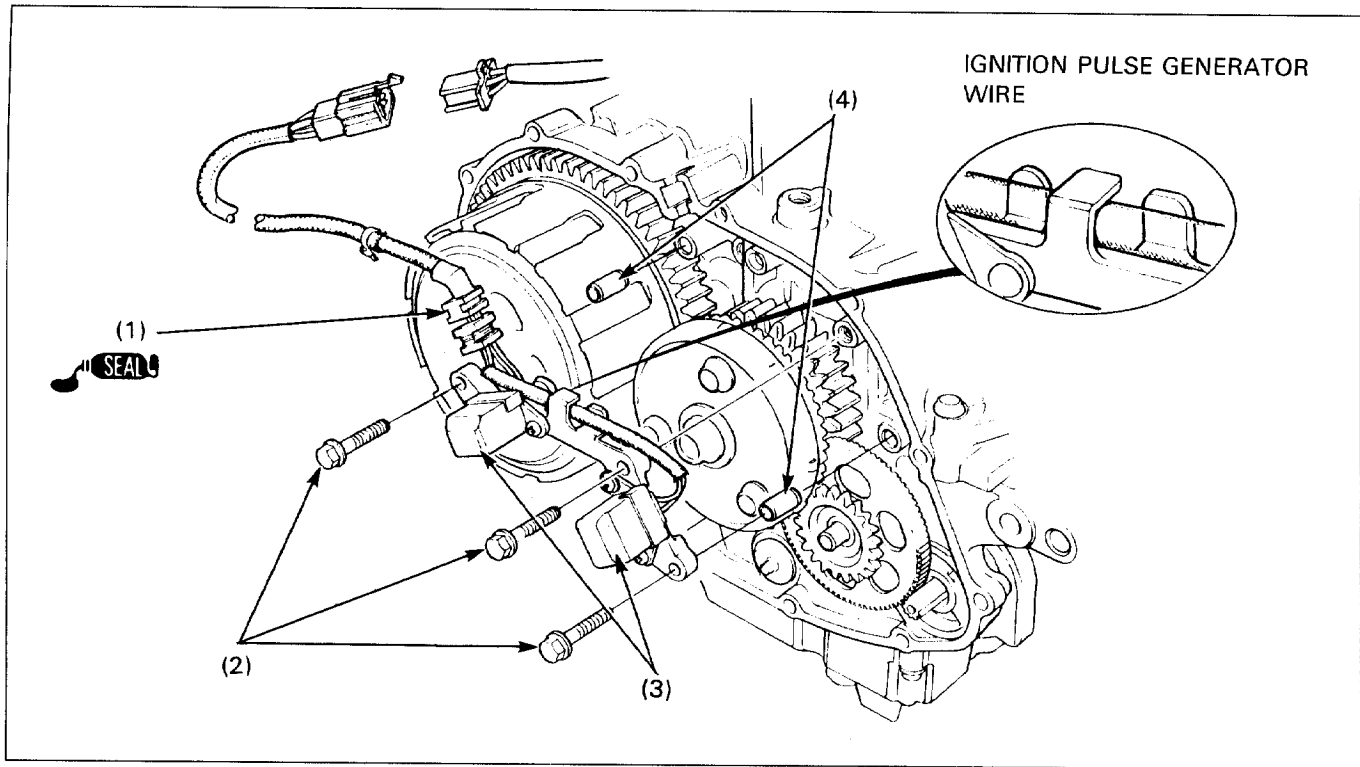

## Requisite Service

- Right crankcase cover removal/installation (page 9-2).

Procedure	Q'ty	Remarks
<b>Removal Order</b>		
(1) Wire grommet	1	• Installation is in the reverse order of removal. Before removing the wire grommet, disconnect the ignition pulse generator 4P mini black connector. Route the ignition pulse generator wire as shown.
(2) Ignition pulse generator mounting bolt	3	
(3) Ignition pulse generator	2	
(4) Dowel pin	2	

# 17. Electric Starter/Starter Clutch

Service Information	17-1	Starter Motor Disassembly/ Assembly	17-8
System Location	17-2		
Circuit Diagram	17-3	Starter Clutch Removal/ Installation	17-10
Troubleshooting	17-4		
Starter Motor Removal/ Installation	17-7	Starter Clutch Disassembly/ Assembly	17-12

## Service Information

### ⚠ WARNING

- Always turn the ignition switch OFF before servicing the starter motor. The motor could suddenly start, causing serious injury.

- A weak battery may be unable to turn the starter motor quickly enough, or supply adequate ignition current.
- If the current is kept flowing through the starter motor to turn it while the engine is not cranking over, the starter motor may be damaged.
- For the following component inspections, refer to the following pages; for the parts locations, see page 17-2 of this manual (SYSTEM LOCATION).

Clutch switch diode	Section 24 of the Common Service Manual.
Starter motor	Section 24 of the Common Service Manual.
Starter relay switch	Section 24 of the Common Service Manual ("A" circuit type).
Clutch switch	Section 25 of the Common Service Manual.
Neutral switch	Page 18-20.
Ignition switch	Check for continuity on the continuity chart of the WIRING DIAGRAM, page 19-1. Disconnect the switch connector inside the upper fairing (page 1-29) and check it.
Side stand switch	(page 18-15)

# System Location

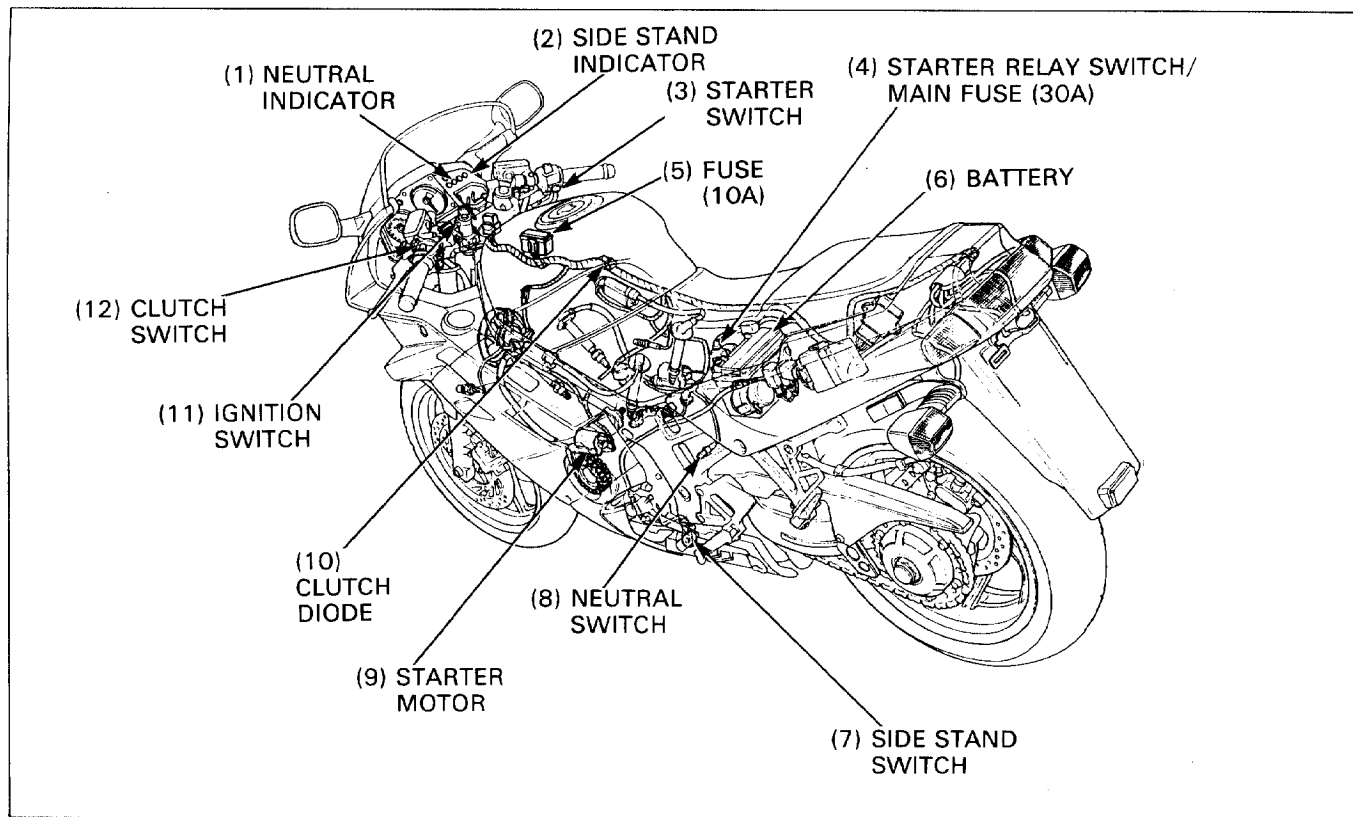

# Circuit Diagram

'90-'93:

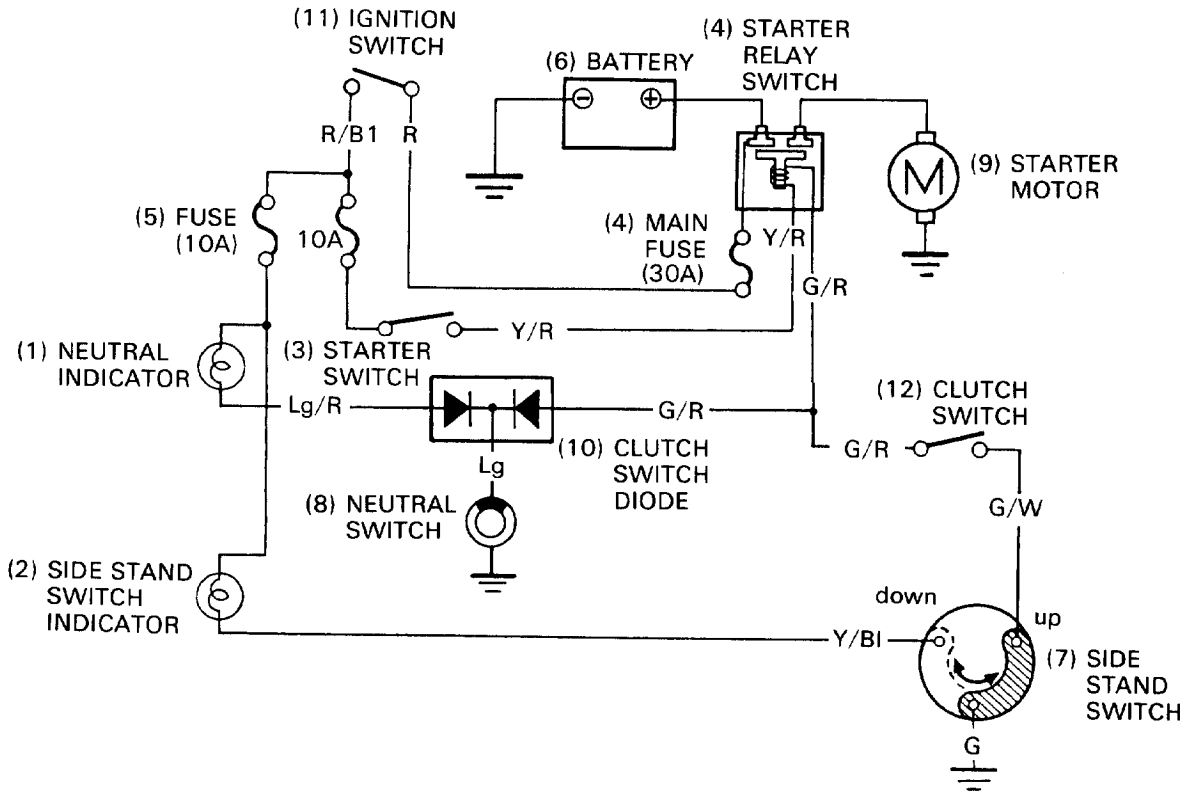

After '93:

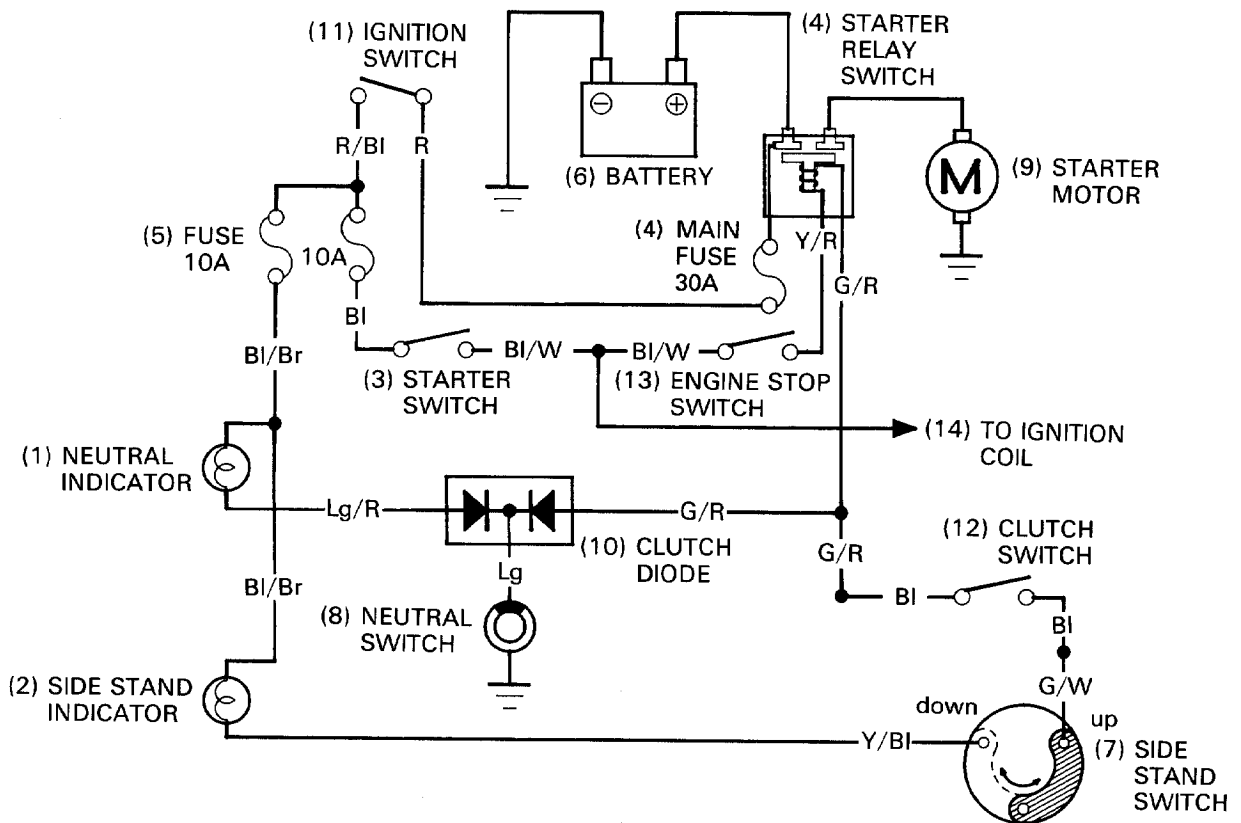

# Troubleshooting

## Starter motor will not turn

'90-'93:

- Check for a blown out main or sub fuses before servicing.
- Make sure the battery is fully charged and in good condition.

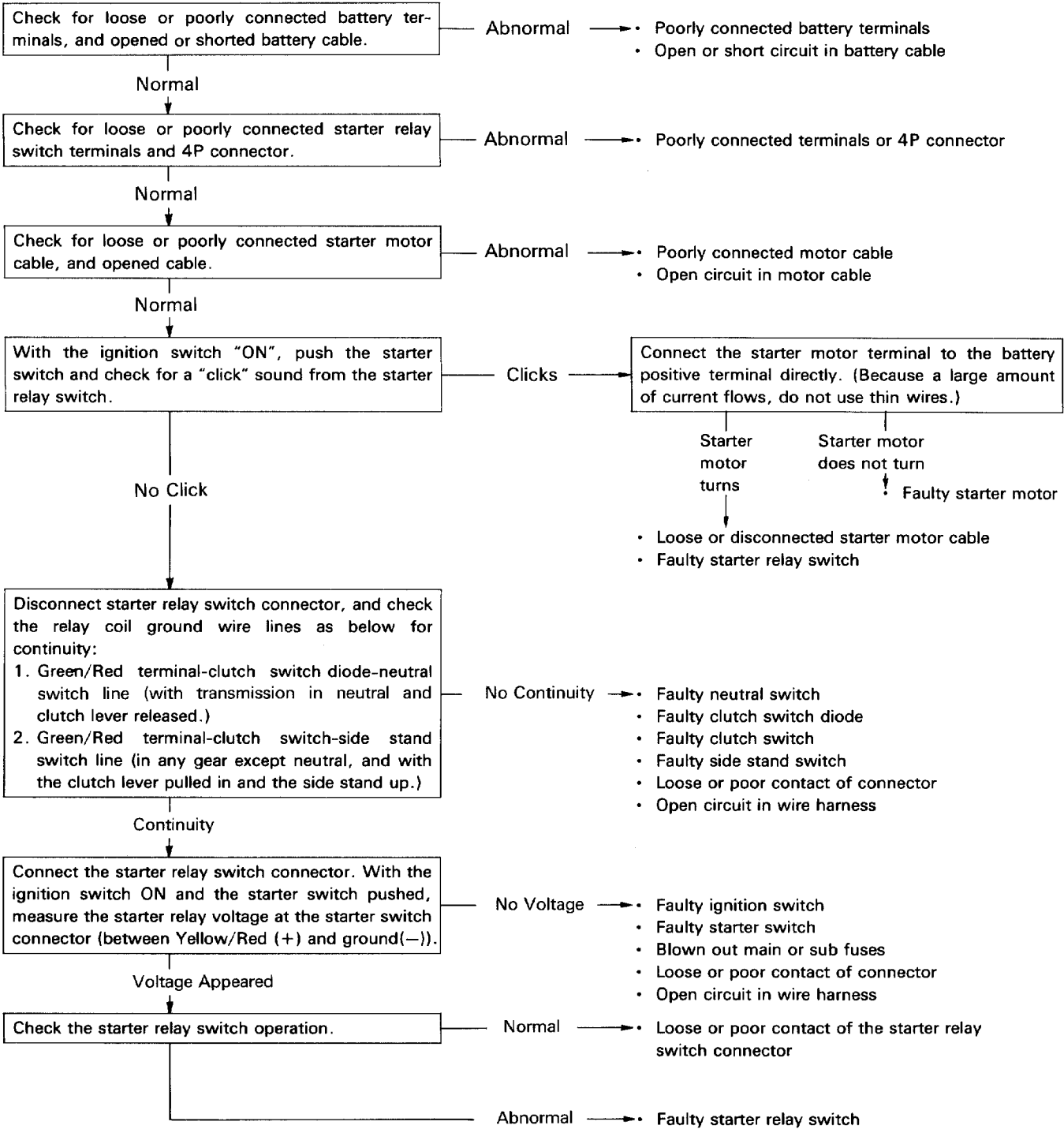

After '93:

- Check for a blown out main or sub fuses before servicing.
- Make sure the battery is fully charged and in good condition.

NOTE

- The starter motor does not turn when the engine stop switch is OFF.

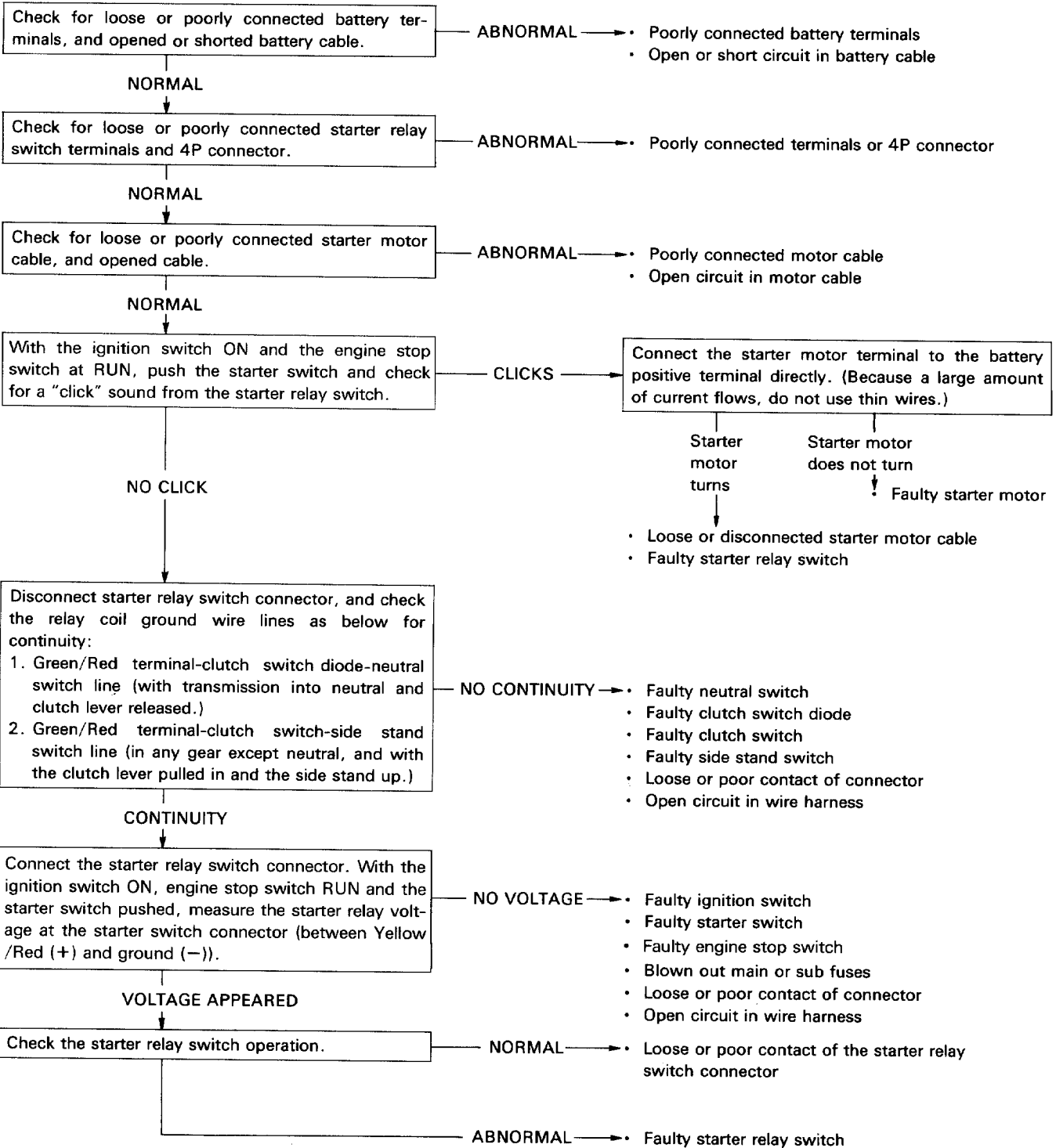

## Electric Starter/Starter Clutch

The starter motor turns when the transmission is in neutral, but does not turn with the transmission in any position except neutral, with the side stand up and the clutch lever pulled in.

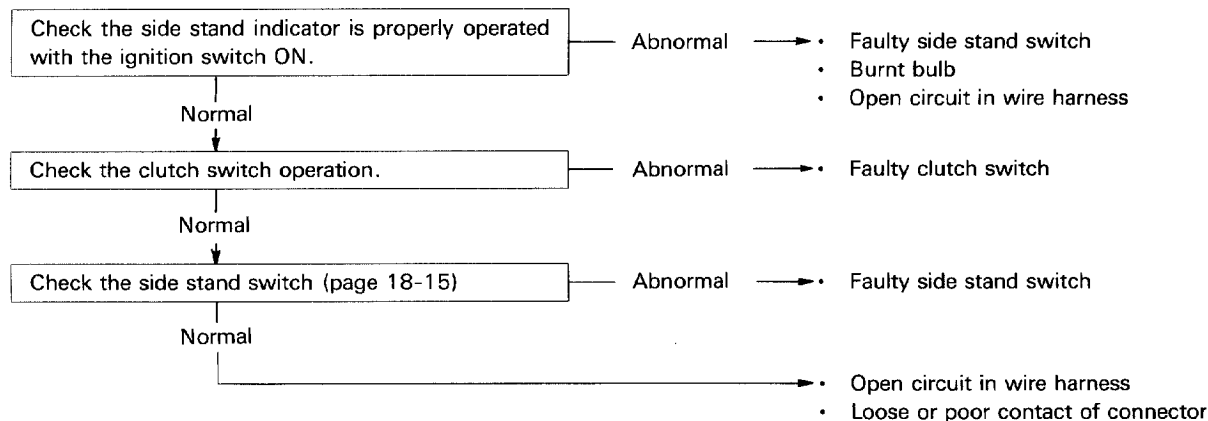

### Starter motor turns slowly

- Low specific gravity in battery (or Dead battery)
- Poorly connected battery terminal cable
- Poorly connected starter motor cable
- Faulty starter motor
- Poorly connected battery ground cable

### Starter motor turns, but engine does not turn

- Starter motor is running backwards
  - Case assembled improperly
  - Terminals connected improperly
- Faulty starter clutch
- Damaged or faulty starter pinion
- Damaged reduction gears

### Starter relay switch "clicks", but engine does not turn over

- Crankshaft does not turn due to engine problems
- Excessive reduction gear friction

# Starter Motor Removal/Installation

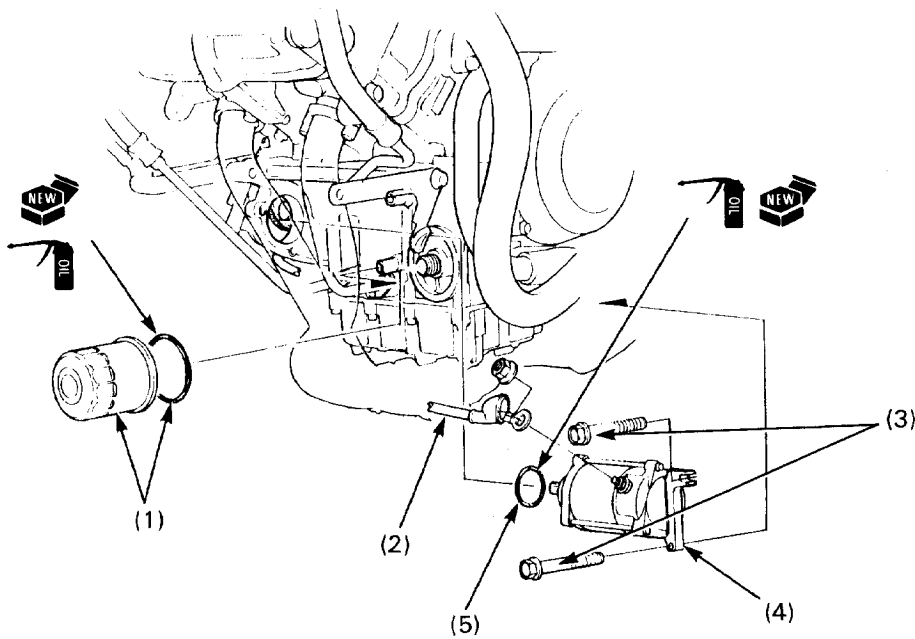

## ⚠ WARNING

- Turn the ignition switch OFF, remove the negative cable at the battery before servicing the starter motor.
- Do not service the starter motor while exhaust pipe is hot.

## Requisite Service

- Lower center fairing removal/installation (page 2-8).

Procedure		Q'ty	Remarks
(1)	<b>Removal Order</b> Oil filter/O-ring	1	• Installation is in the reverse order of removal. When installing, apply oil to the O-ring. Add the recommended engine oil to the upper level after installation (refer to Common Service Manual, section 2).
(2)	Starter motor cable	1	
(3)	Starter motor mounting bolt	2	
(4)	Starter motor	1	
(5)	O-ring	1	Apply oil when installing.

# Starter Motor Disassembly/Assembly

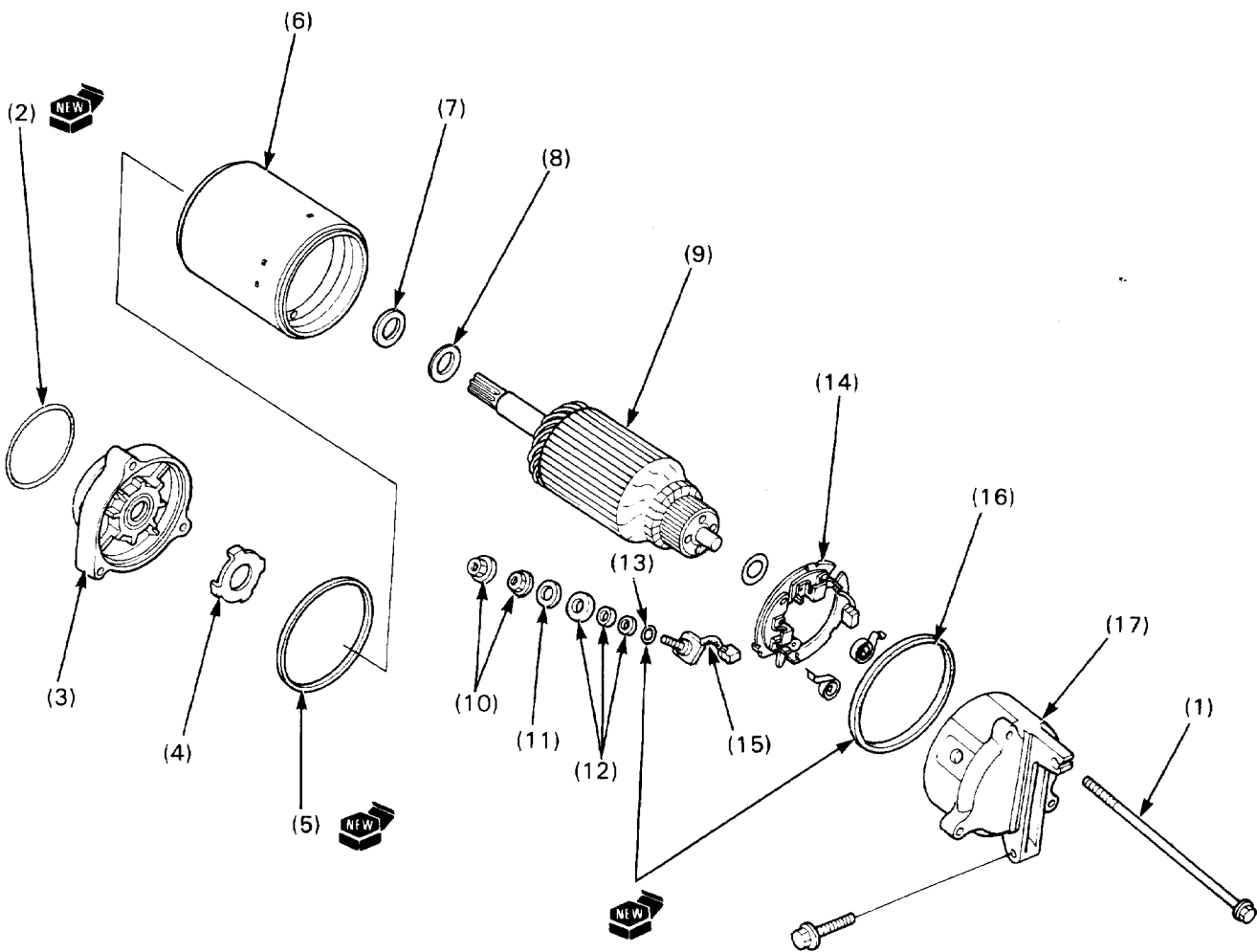



**Requisite Service**

- Starter motor removal/installation (page 17-7).

Procedure		Q'ty	Remarks
	<b>Disassembly Order</b>		• Assembly is in the reverse order of removal.
(1)	Case bolt	3	
(2)	O-ring	1	
(3)	Front cover	1	Align the index marks on the cover and case.
(4)	Lock washer	1	
(5)	O-ring	1	
(6)	Motor case	1	Align the index marks on the rear cover and case.
(7)	Insulated washer	1	
(8)	Washer	1	
(9)	Armature	1	
(10)	Brush terminal holding nut	2	
(11)	Washer	1	
(12)	Insulated washer	3	
(13)	O-ring	1	
(14)	Brush holder assembly	1	Align the holder tab with the rear cover groove.
(15)	Brush and terminal	1	
(16)	O-ring	1	
(17)	Rear cover	1	

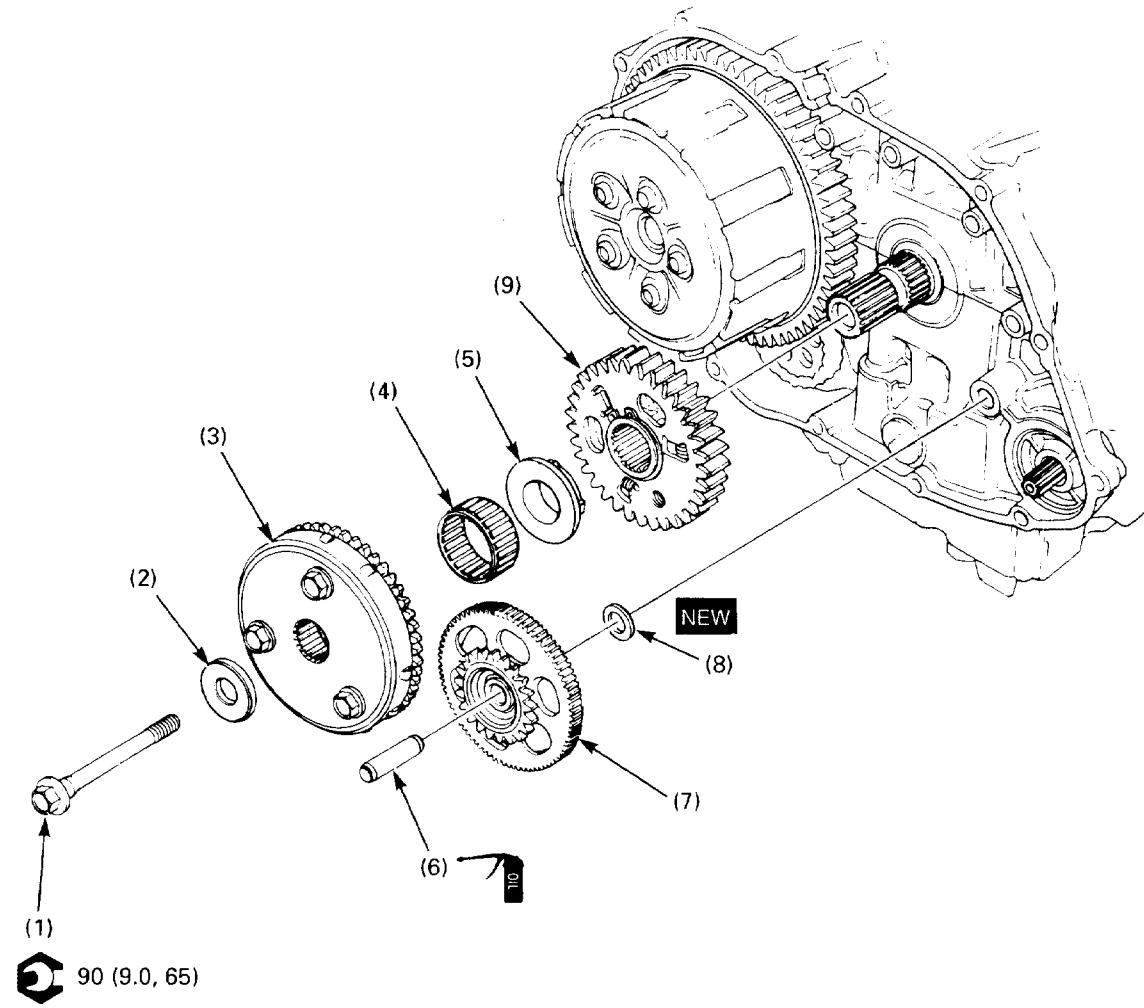
# Starter Clutch Removal/Installation



 90 (9.0, 65)

 GEAR HOLDER (page 1-24)

ALIGN THE WIDE GROOVE WITH THE CRANKSHAFT SPLINE AS SHOWN

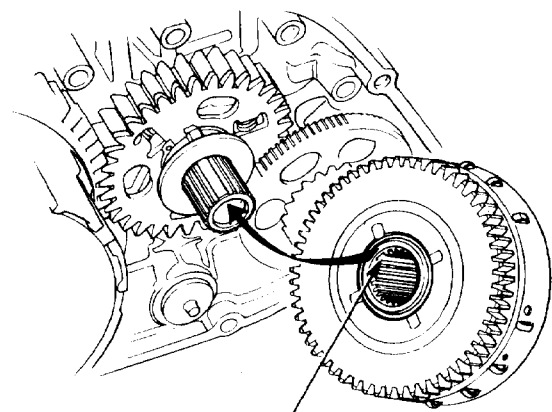
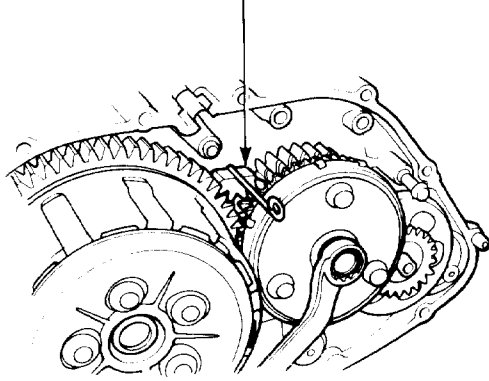

WIDE GROOVE

**Requisite Service**

- Right crankcase cover removal/installation (page 9-2).
- Ignition pulse generator removal/installation (page 16-10).

Procedure		Q'ty	Remarks
	<b>Removal Order</b>		• Installation is in the reverse order of removal.
(1)	Starter clutch bolt	1	
(2)	Washer		
(3)	Starter clutch assembly	1	
(4)	Needle bearing	1	
(5)	Primary drive gear guide	1	
(6)	Starter reduction gear shaft	1	
(7)	Starter reduction gear	1	
(8)	Washer	1	<b>NEW</b>
(9)	Primary drive gear assembly	1	

# Starter Clutch Disassembly/Assembly

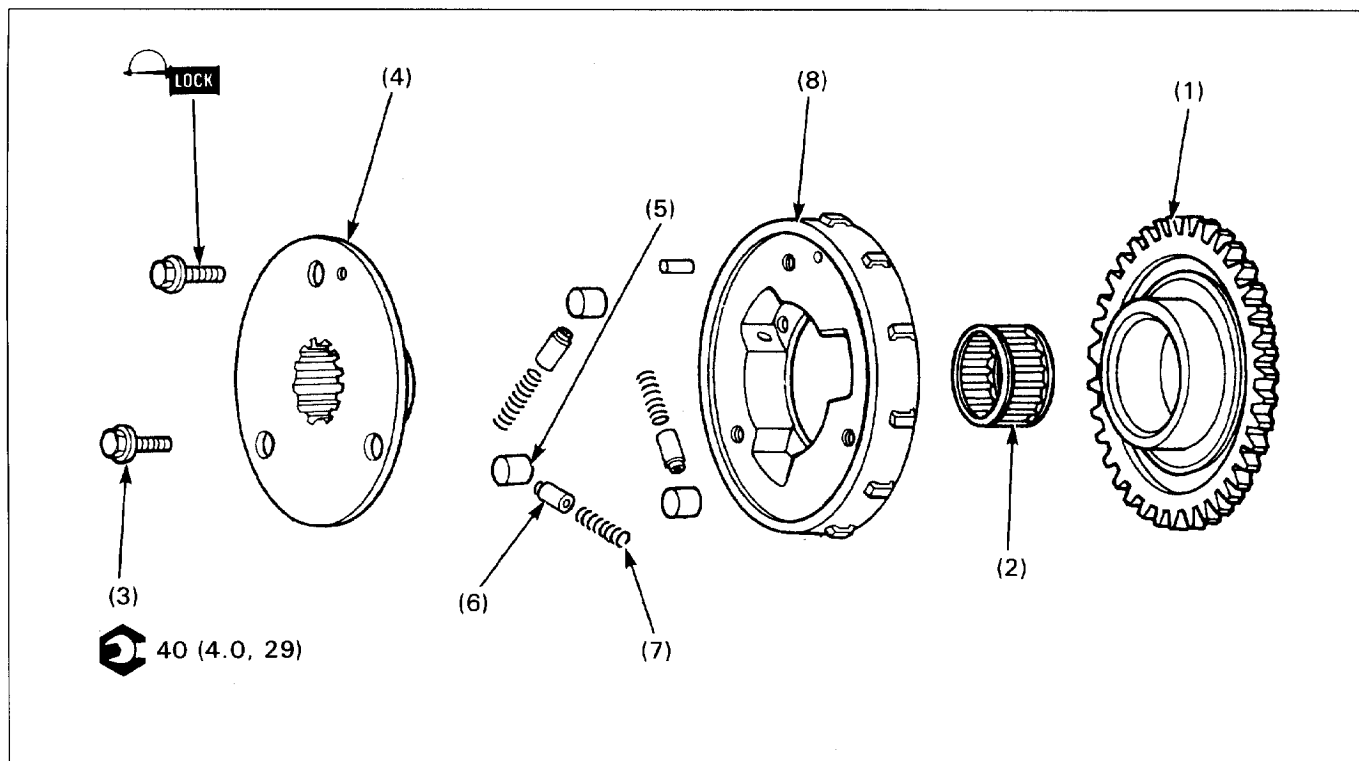

## Requisite Service

- Starter clutch removal/installation (page 17-10).

Procedure		Q'ty	Remarks
<b>Disassembly Order</b>			
(1)	Starter driven gear	1	• Assembly is in the reverse order of disassembly. Rotate clockwise, when installing.
(2)	Needle bearing	1	
(3)	Starter clutch outer cover bolt	3	Apply a locking agent to the threads at installation. Align the pin on the outer with the hole of the cover when installing.
(4)	Starter clutch outer cover	1	
(5)	Roller	3	Be careful not to pop them out.
(6)	Plunger	3	
(7)	Spring	3	
(8)	Starter clutch outer	1	

# 18. Lights/Meters/Switches

Service Information	18-1	Ignition Switch Removal/Installation	18-14
System Location	18-2	Side Stand Switch	18-15
Troubleshooting	18-3	Fuel Level Sensor/Fuel Gauge	18-15
Headlight Bulb Replacement	18-5	Low Fuel Indicator	18-16
Headlight Removal/Installation	18-6	Fuel Pump	18-17
Turn Signal Light	18-7	Coolant Temperature Gauge	18-17
Taillight	18-7	Thermosensor	18-18
Indicator Bulb Replacement	18-8	Oil Pressure Switch	18-19
Combination Meter Removal/ Installation	18-9	Fan Motor Switch	18-19
Combination Meter Disassembly/ Assembly	18-11	Diode	18-20
Tachometer Inspection	18-14	Neutral Switch	18-20
		Headlight Relay	18-20
		High Beam Relay	18-21

## Service Information

### ⚠ WARNING

- The halogen headlight bulb becomes very hot while the headlight is ON, and remains hot for a while after it is turned OFF. Be sure to let it cool down before servicing.
- Use a heating element to heat water/coolant mixture for thermosensor inspection. Keep all flammable materials away from the burner. Wear protective clothing, gloves and eye protection.

- Note the following when replacing the halogen headlight bulb.
  - Wear clean gloves while replacing the bulb. Do not put finger prints on the headlight bulb, as they may create hot spots on the bulb and cause it to break.
  - If you touch the bulb with your bare hands, clean it with a cloth moistened with alcohol to prevent its early failure.
  - Be sure to install the dust cover after replacing the bulb.
- Check the battery condition before performing any inspection that requires proper battery voltage.
- A continuity test can be made with the switches installed on the motorcycle. Continuing charts are included on the wiring Diagram.
 

For the following component locations, see page 18-2 of this manual (SYSTEM LOCATION); for inspections, refer to the applicable pages.

Component	Inspection method	Remarks
Clutch switch	Section 25 of the Common Service Manual	
Front brakelight switch	Section 25 of the Common Service Manual	
Horn	Section 25 of the Common Service Manual	
Handlebar switches	Check for continuity on the continuity chart of the WIRING DIAGRAM, page 19-1.	
Ignition switch		
Rear brakelight switch	Section 25 of the Common Service Manual	
Turn signal lights	Section 25 of the Common Service Manual	3 terminals relay.

# System Location

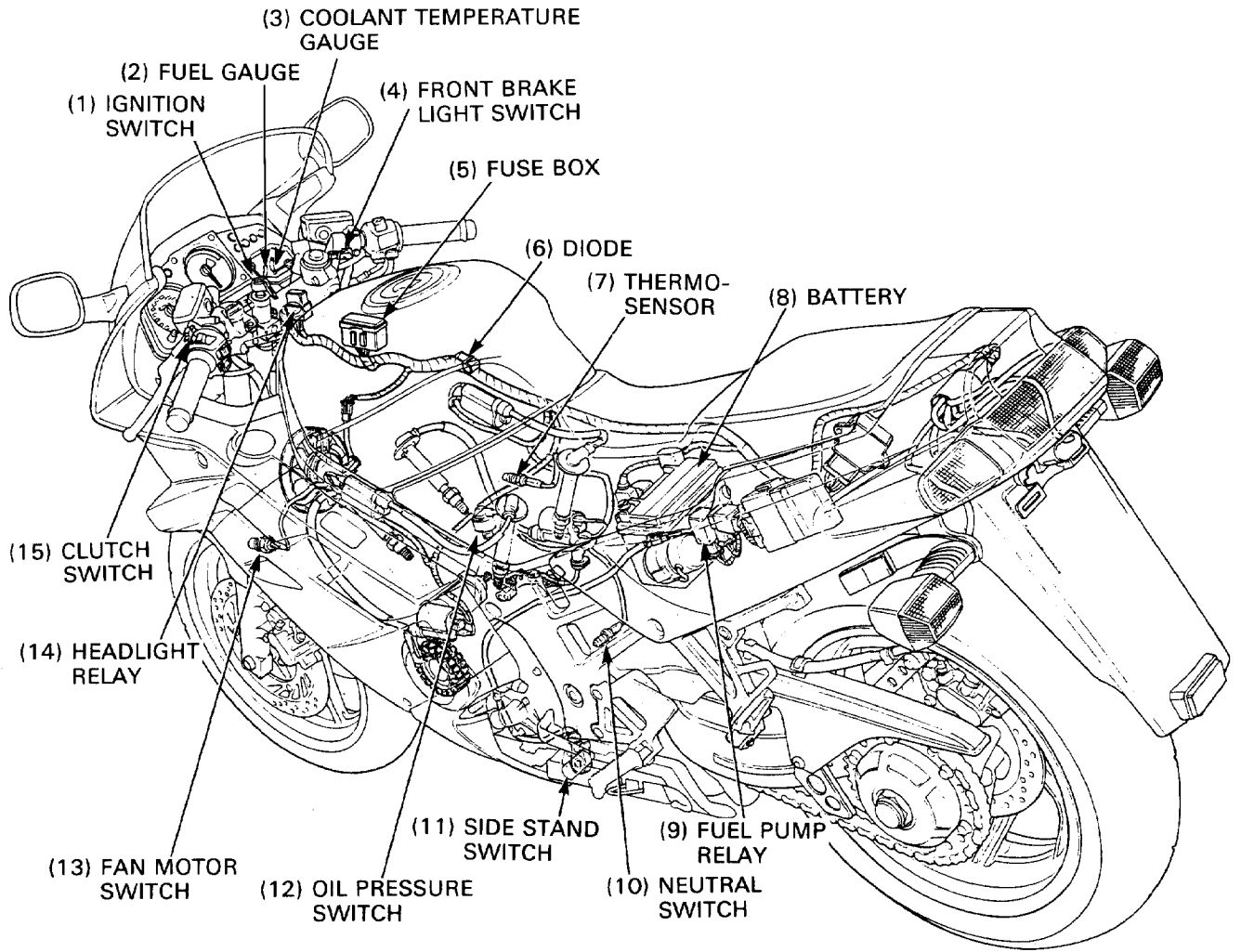

# Troubleshooting

## Speedometer Does Not Operate (After '93)

- Check for the following before diagnosing.
  - blown main or sub fuses
  - loose or corroded terminals of the connectors
  - discharged battery

Remove the rear fairing (page 2-3).  
 Check for battery voltage between the Black and Green terminals at the speed sensor connector with the connector remained connected and the ignition switch ON.

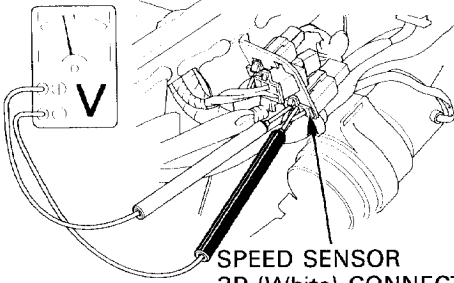

**Connection:**  
 Black (+) - Green (-)

Battery voltage

No battery voltage

- Loose or poor contact of sensor 3P connector.
- Open circuit in Black, Black/Brown or Green/Black wires.

Removal the upper fairing (page 2-12).  
 Check for battery voltage between the screws at the printed circuit board on the bottom of the meter assembly with the ignition switch ON as shown.

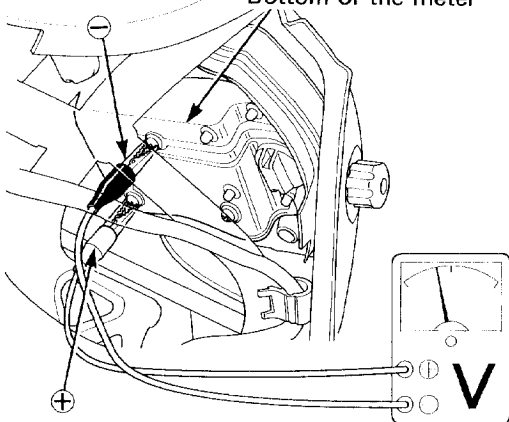

Battery voltage

No battery voltage

- Loose or poor contact of meter 10P (Green) connector.
- Open circuit in Black/Brown or Green/Black wires of the meter 10P Green connector.
- Faulty printed circuit board.

(Continue to the following page)

(From the previous page)

With the ignition switch OFF, check for continuity between the Pink wire (sensor signal line) terminals at the speed sensor connector and printed circuit board screw with the connector remained connected as shown.

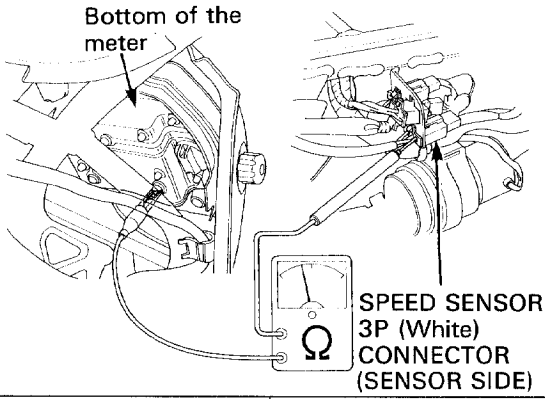

No continuity

- Loose or poor contact of sensor 3P connector or meter 10P (Green) connector.
- Open circuit in Pink wire.
- Faulty printed circuit board.

Continuity

Place the motorcycle on its center stand. Measure the output voltage (sensor signal) between the Pink terminal at the meter 10P Green connector and body ground with the connector remained connected and the ignition switch ON while turning the rear wheel slowly by hand.

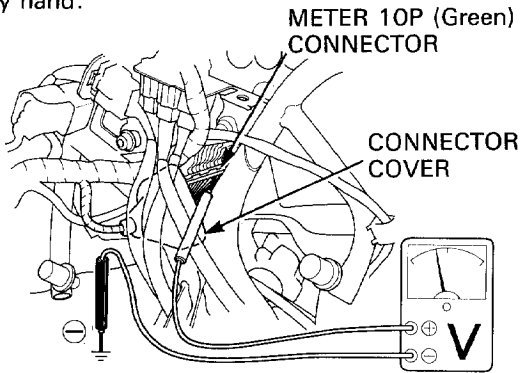

Abnormal  
(No input sensor signal)

- Faulty speed sensor.

View from harness side

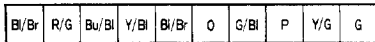

Standard: 4.7-5.3 V

Connection: Pink(+)-Ground(-)

Normal (Sensor signal is input the speedometer)

Faulty speedometer

# Headlight Bulb Replacement

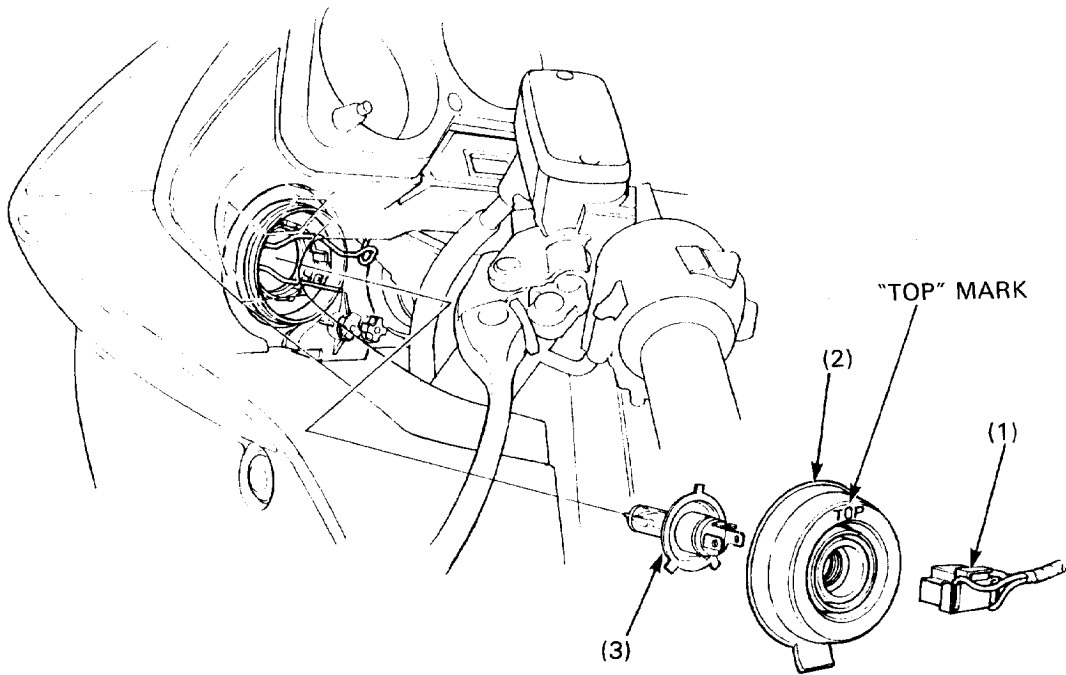

## ⚠ WARNING

- The halogen headlight bulb becomes very hot while the headlight is ON, and remains hot for a while after it is turned OFF. Be sure to let it cool down before servicing.

## CAUTION

- Wear clean gloves while replacing the bulb. Do not put finger prints on the headlight bulb, as they may create hot spots on the bulb and cause it to break.
- If you touch the bulb with your bare hands, clean it with a cloth moistened with alcohol to prevent its early failure.
- Be sure to install the dust cover after replacing the bulb.

Procedure	Q'ty	Remarks
<b>Removal Order</b>		• Installation is in the reverse order of removal.
(1) Headlight connector	1	
(2) Dust cover	1	Install it with the TOP mark facing up.
(3) Headlight bulb	1	

# Headlight Removal/Installation

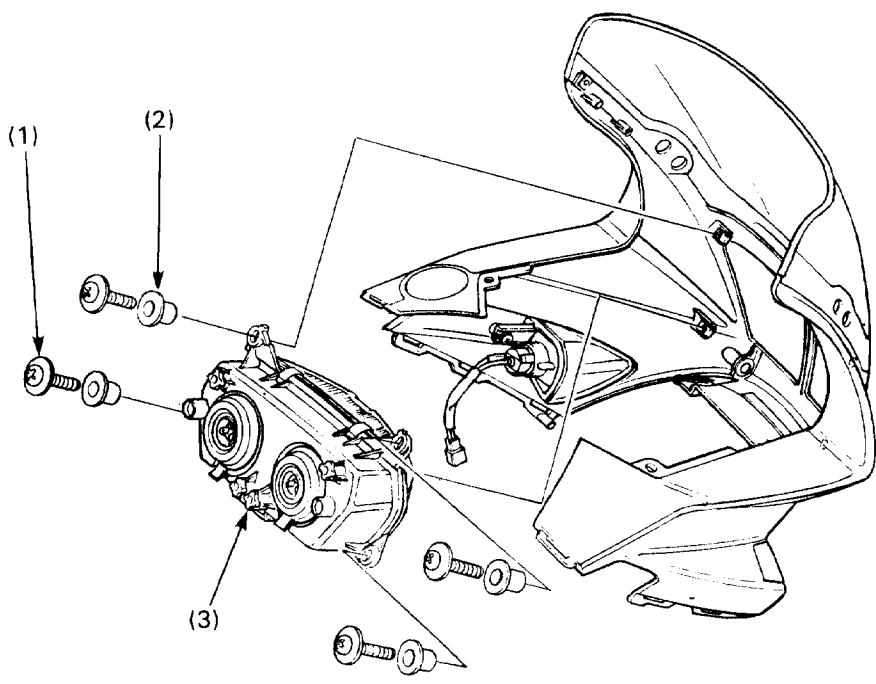

## Requisite Service

- Upper fairing removal/installation (page 2-10).

Procedure		Q'ty	Remarks
<b>Removal Order</b>			• Installation is in the reverse order of removal.
(1)	Headlight mounting screw	4	
(2)	Collar	4	'90-'93 only
(3)	Headlight	1	

# Turn Signal Light

## Front

Turn the bulb socket counterclockwise and remove it.  
Turn the bulb counterclockwise and remove it.

Install a new bulb in the reverse order of removal.

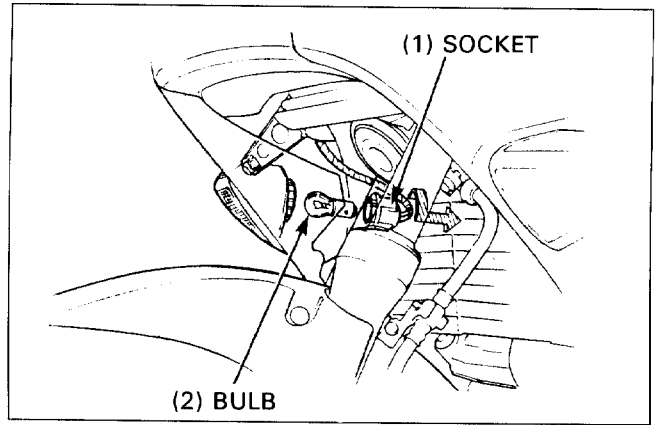

## Rear

Remove the screw and the turn signal light lens.  
Remove the bulb socket by turning it counterclockwise.  
Remove the bulb by turning it counterclockwise while pushing the bulb in lightly.  
Install a new bulb and other removed parts in the reverse order of removal.

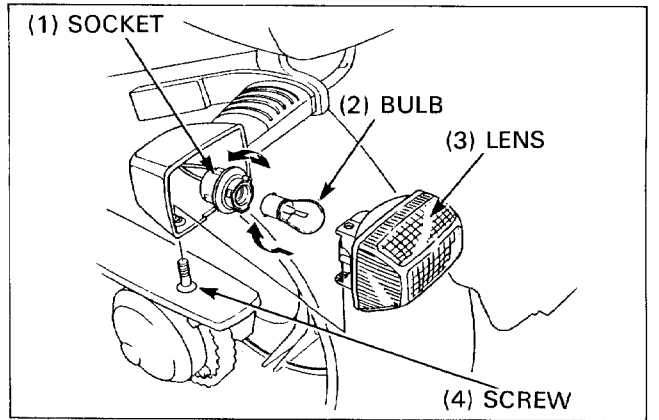

# Taillight

Remove the seat (page 2-2).  
Turn the bulb socket counterclockwise and remove it.  
Turn the bulb counterclockwise and remove it.

Install a new bulb in the reverse order of removal.

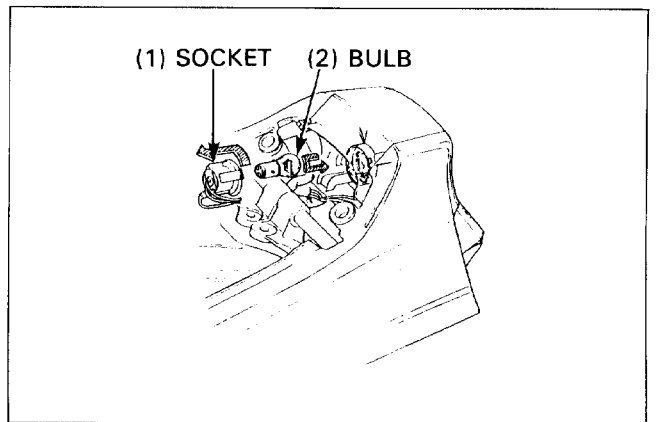

# Indicator Bulb Replacement

(After '93)

Remove the upper fairing (page 2-12).

Turn the bulb socket counterclockwise and remove the bulb socket and bulb.

Install a new bulb and install the removed parts in the reverse order of removal.

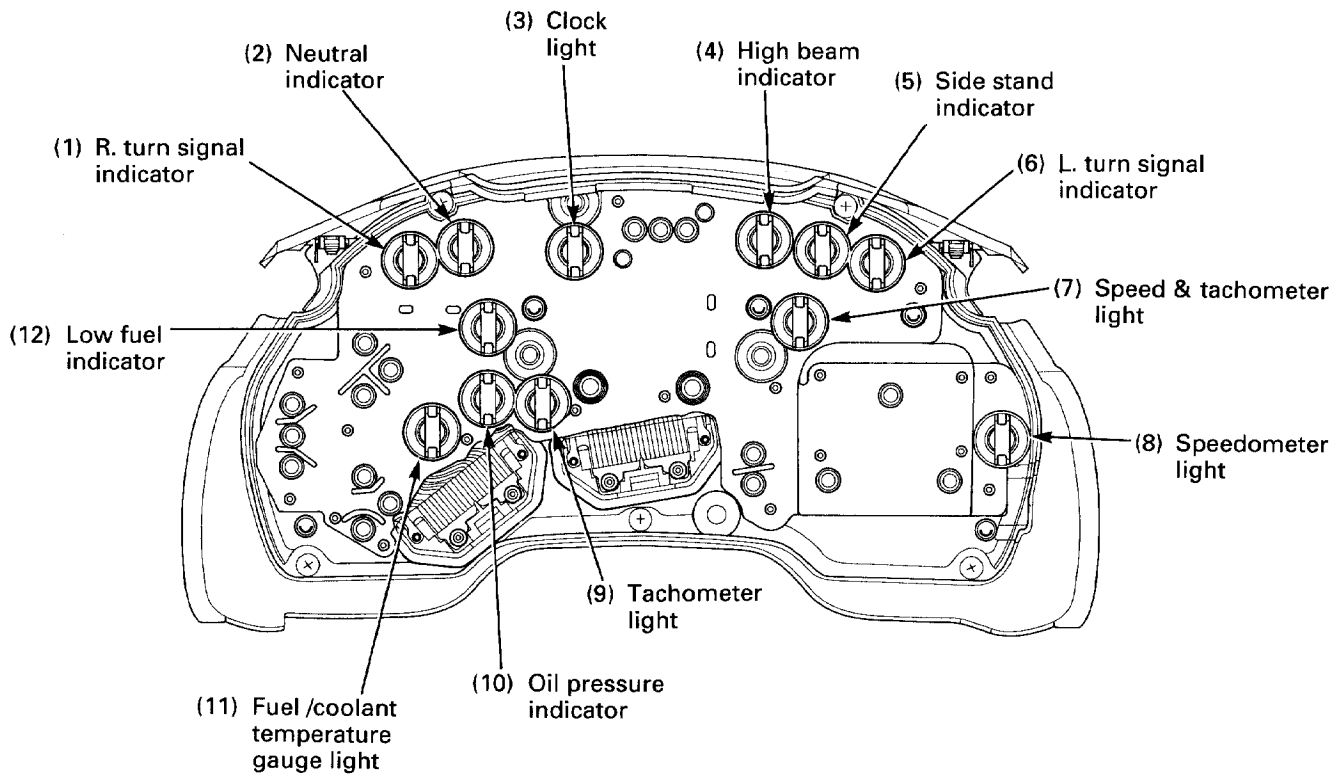
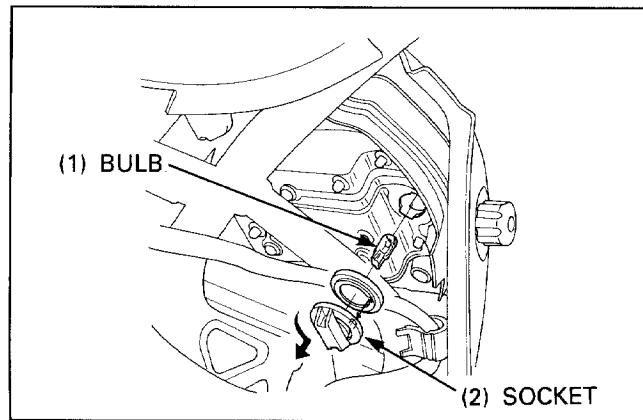

# Combination Meter Removal/Installation

'90-'93:

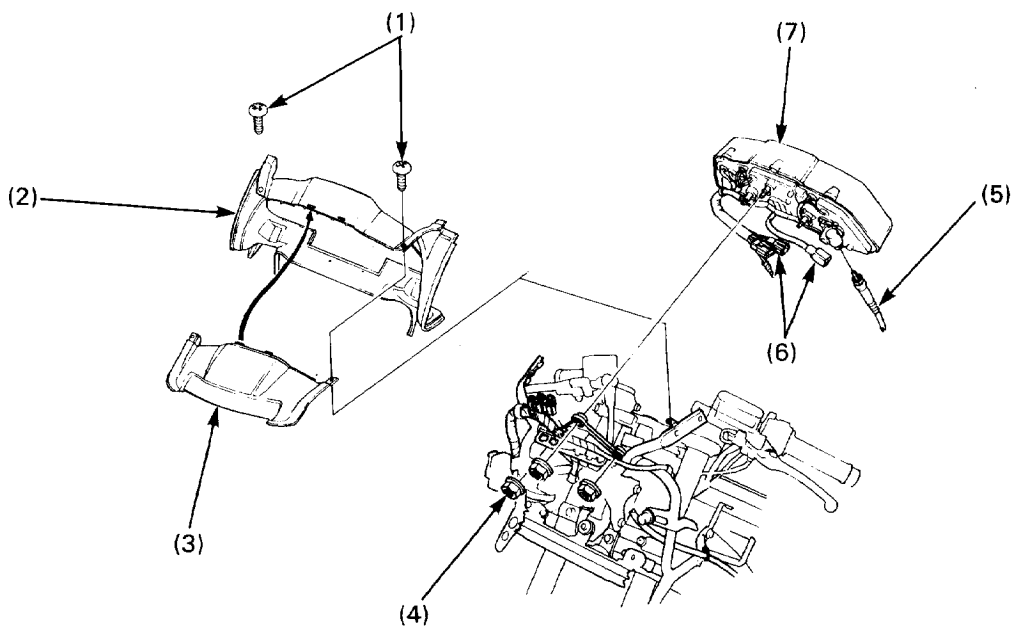

## Requisite Service

- Headlight removal/installation (page 18-6).

Procedure	Q'ty	Remarks
<b>Removal Order</b>		• Installation is in the reverse order of removal.
(1) Meter cover screw	2	
(2) Meter cover	1	
(3) Front meter cover	1	
(4) Meter mounting nut	3	
(5) Speedometer cable	1	
(6) Meter connector	4	4P mini White, 4P mini Black, 6P mini White and Yellow/ Green connectors.
(7) Meter assembly	1	

After '93:

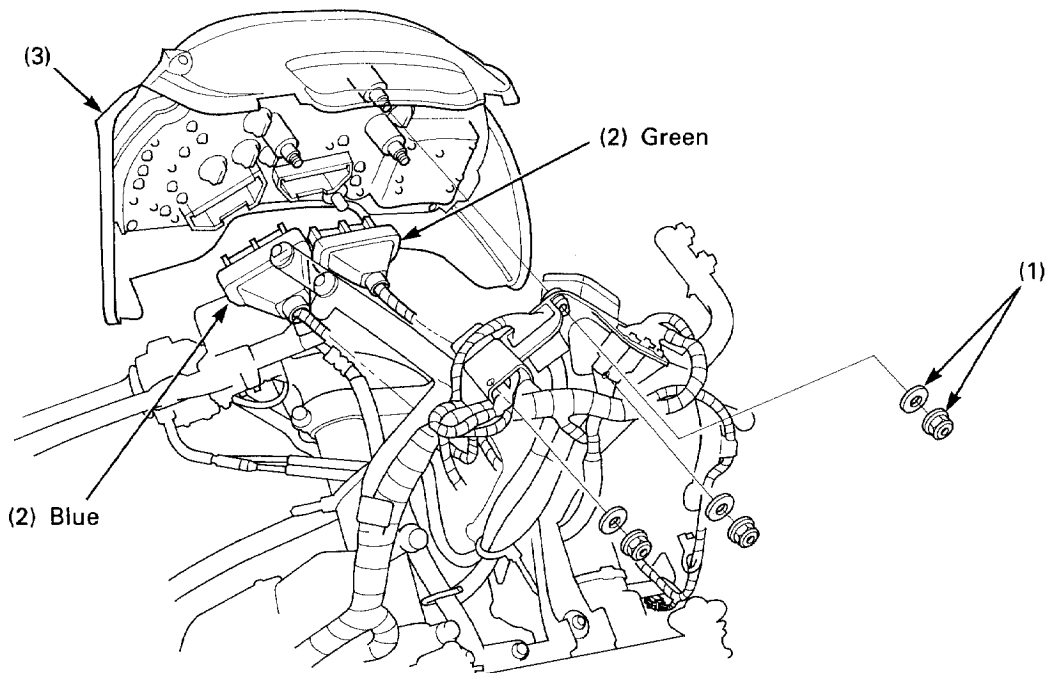

**Requisite Service**

- Upper fairing removal/installation (page 2-12)

Procedure		Q'ty	Remarks
	<b>Removal Order</b>		Installation is in the reverse order of removal.
(1)	Nut/cone spring washer	3/3	<b>CAUTION:</b> • Be careful not to damage the printed circuit board on the bottom of the meter assembly.
(2)	Meter connector	2	
(3)	Meter assembly	1	

# Combination Meter Disassembly/Assembly

'90-'93:

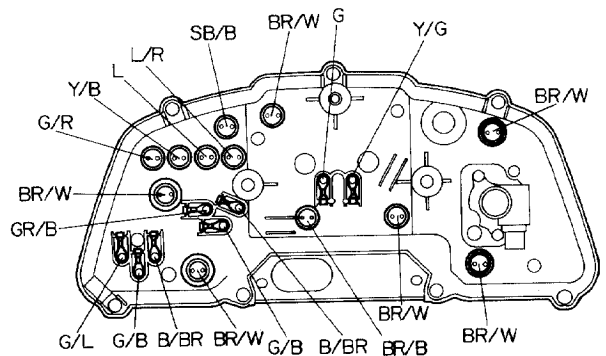
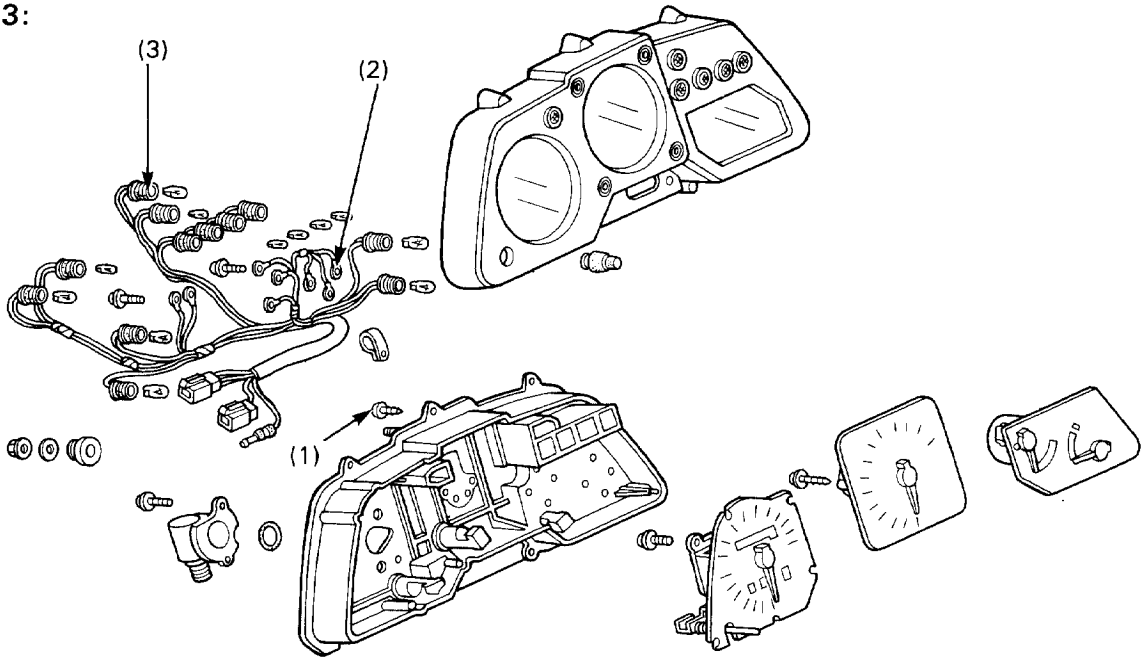

**NOTE**

- Connect the terminals and install the sockets according to the collar codes indicated on the back panel. The color codes (on 19-1 page) are for connection of the combination meter wire harness.

**Requisite Service**

- Combination meter removal/installation (page 18-9)

Procedure	Q'ty	Remarks
<b>Removal Order</b>		• Installation is in the reverse order of removal.
(1) Wire clamp/screw	1	
(2) Wire harness terminal	8	Remove the terminal screws and disconnect the harness connectors.
(3) Meter bulb socket	11	Pull the sockets and bulbs out of the back panel as an assembly.

After '93:

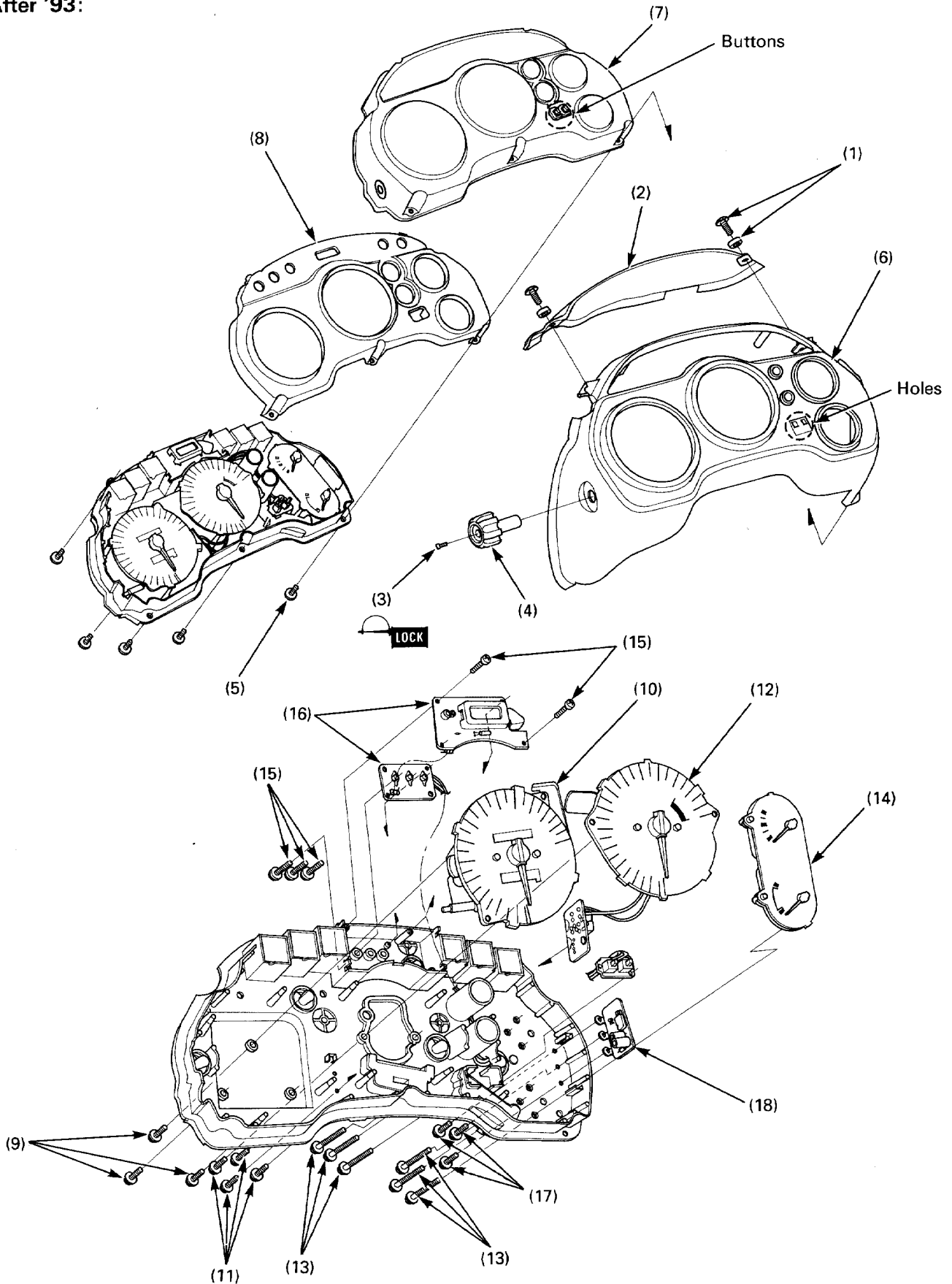

**Requisite Service**

- Combination meter removal/installation (page 18-10)

Procedure		Q'ty	Remarks
<b>Disassembly Order</b>			Assembly is in the reverse order of disassembly.
(1)	Screw/collar	2/2	At installation, align the holes with the clock adjusting buttons on the meter lens securely.
(2)	Cover	1	
(3)	Screw	1	
(4)	Reset knob	1	
(5)	Screw	5	
(6)	Visor	1	
(7)	Lens	1	
(8)	Plate	1	
(9)	Screw	3	
(10)	Speedometer	1	
(11)	Screw	4	
(12)	Tachometer	1	
(13)	Screw	6	
(14)	Fuel/temperature gauge	1	
(15)	Screw	5	
(16)	Clock unit	1	
(17)	Screw	3	
(18)	Indicator check unit	1	

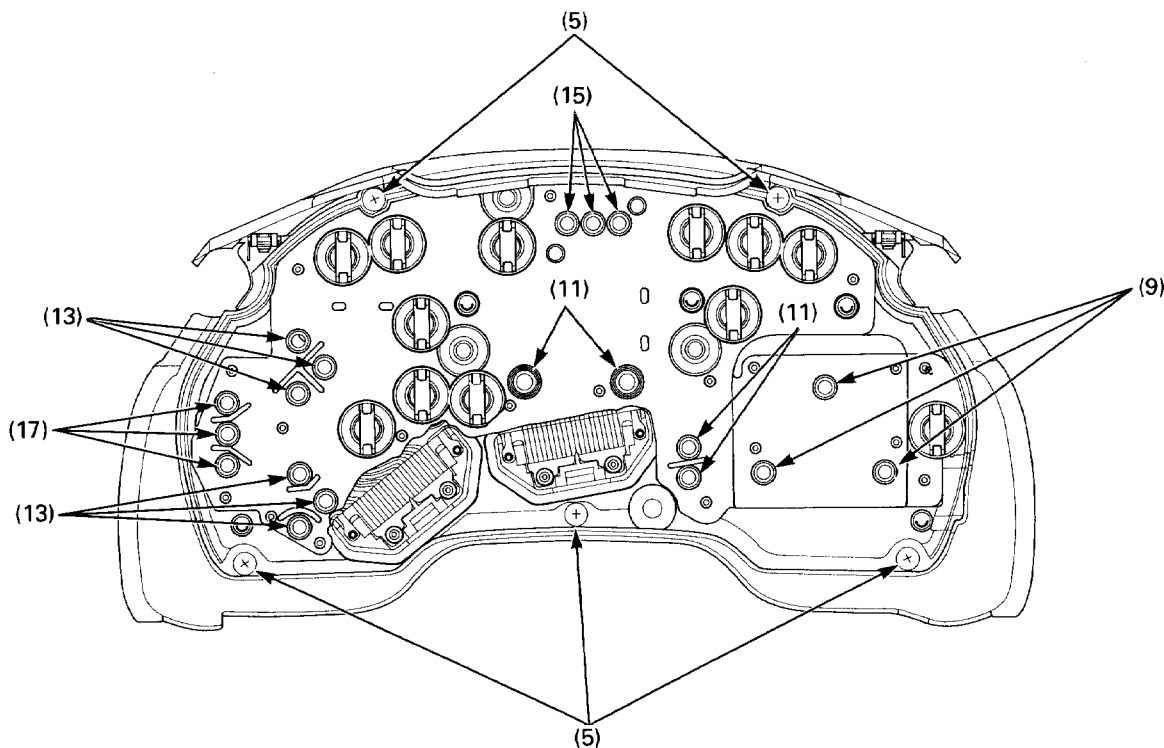

## Tachometer Inspection

Remove the upper fairing (page 2-10) and disconnect the 6P mini Black connector and Yellow/Green connector (After '93: 10P Green connector).

Connect a voltmeter across the Yellow/Green(+) and Green(-) terminals of the main wire harness side.

Turn the ignition switch ON and battery voltage should register.

If the battery voltage is not measured, the electric tachometer is not receiving power from the battery. Trace and repair the related wiring, sub fuse and/or connectors.

Remove the rear fairing (page 2-3).

Disconnect the ignition control module (ICM) connector. Check for continuity between the Yellow/Green wire terminals of the 6P mini White connector (After '93: 10P Green connector) and ICM connector.

Continuity should exist at all test points.

If there is no continuity, replace the main wire harness.

If all checks are O.K., replace the tachometer.

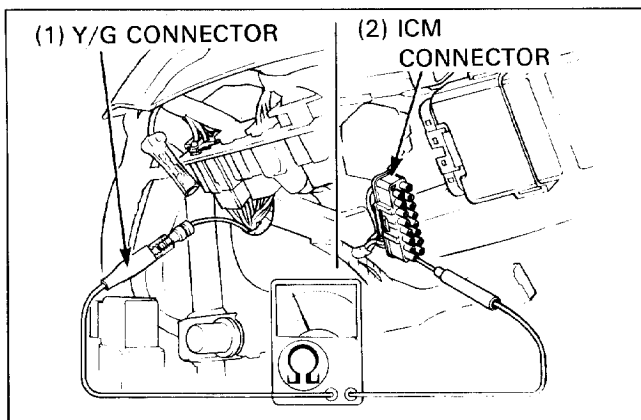
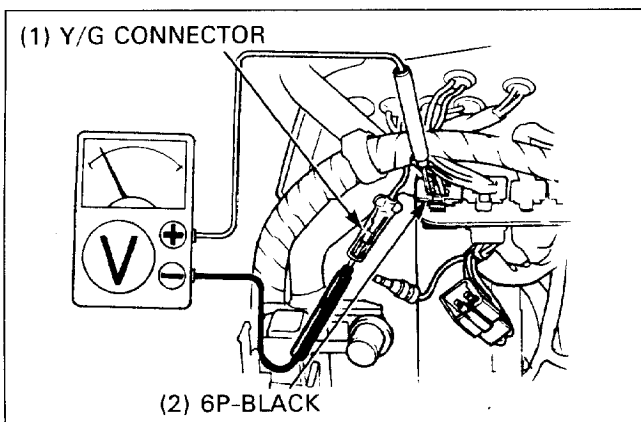

## Ignition Switch Removal/Installation

Remove the steering stem (page 12-16).

Remove the ignition switch mounting bolts.

Install a new ignition switch with two mounting bolts.

**Torque: 25 N·m (2.5 kg-m, 18 ft-lb)**

After installation, install the steering stem (page 12-16).

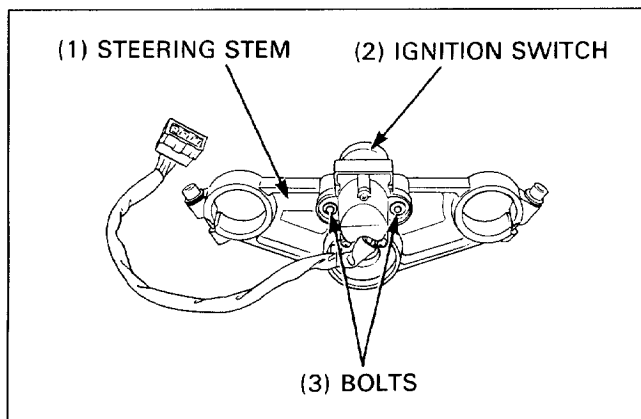

# Side Stand Switch

## Inspection

Disconnect the side stand 3P mini green connector located on rear left side (page 1-29) and check for continuity between each terminals as shown below.

There should be continuity between the ○—○ positions on the continuity chart.

	Green/White	Yellow/Black	Green
Side stand down		○—○	○—○
Side stand up	○—○		○—○

## Removal/Installation

Disconnect the side stand connector (page 1-29).  
Remove the lower fairing (page 2-7).

With the side stand up, remove the side stand switch mounting bolt and side stand switch.

Install the switch in the reverse order of removal.

### NOTE

- Align the switch pin with the side stand hole and align the switch groove with the side stand return spring holding pin.

### Torque:

Side stand switch mounting bolt:  
9 N·m (0.9 kg-m, 7 ft-lb)

Route the side stand switch wires properly (page 1-29)

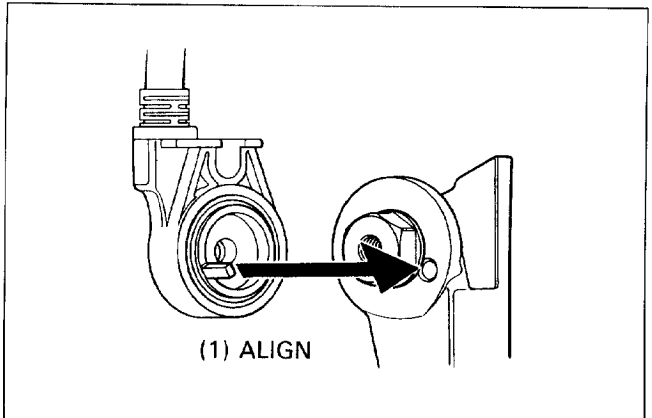
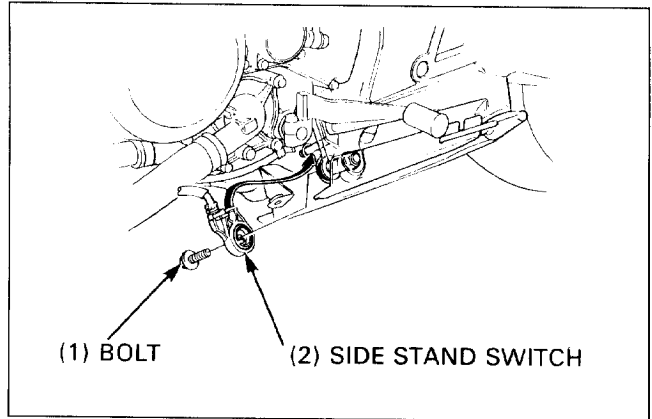
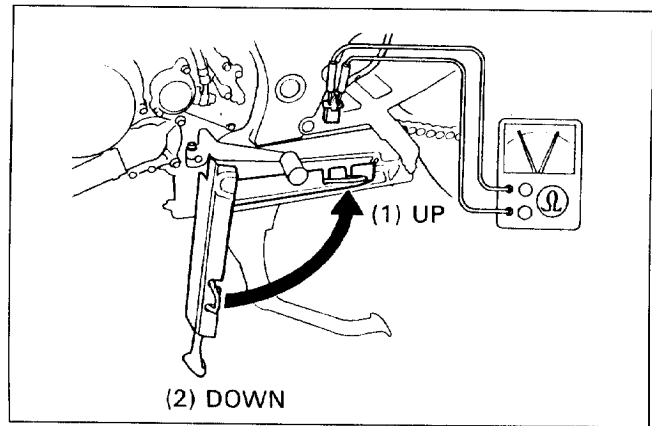

# Fuel Level Sensor/Fuel Gauge

## Inspection

### Fuel Gauge

Remove the fuel level sensor (page 6-6).

Connect the fuel level sensor connector, and then turn the ignition switch "ON".

Move the float up and down to be sure that fuel gauge needle moves to "F" and "E".

If the needle does not move, inspect the fuel level sensor (page 18-16).

If the fuel level sensor is good, check for a loose connector, or an open circuit in the wire harness.

Replace the gauge if necessary.

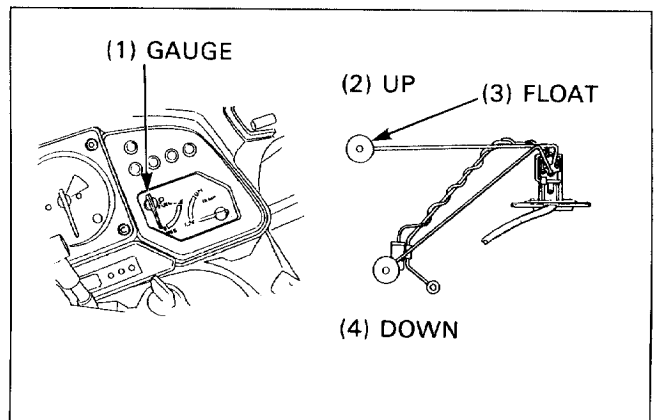

**Fuel Level Sensor**

Remove the fuel level sensor (page 6-6)

Measure the resistance with float in up and down positions.

**STANDARD:**

**UP:** 4-10Ω (20°C/68°F)

**DOWN:** 90-100Ω (20°C/68°F)

Replace if necessary.

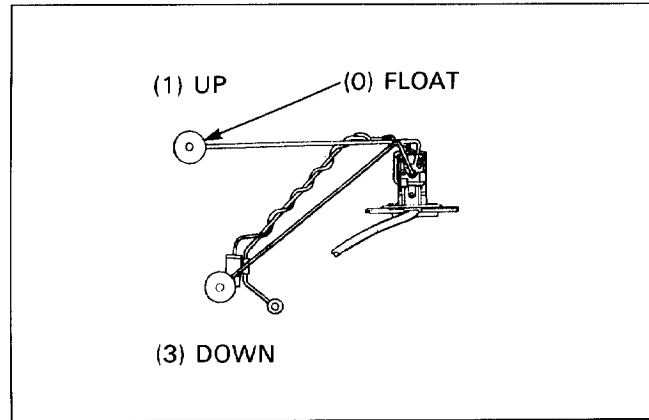

**Low Fuel Indicator**

**Inspection**

Remove the fuel tank (page 2-22).

Make sure that the fuel tank is filled with enough gasoline to submerge the fuel level sensor unit.

If the low fuel indicator does not go off, check as noted below.

Check for battery voltage between the fuel level sensor connector terminals.

Battery voltage exists

- Faulty fuel level sensor

No battery voltage

- Shorted wire between the indicator light and sensor.

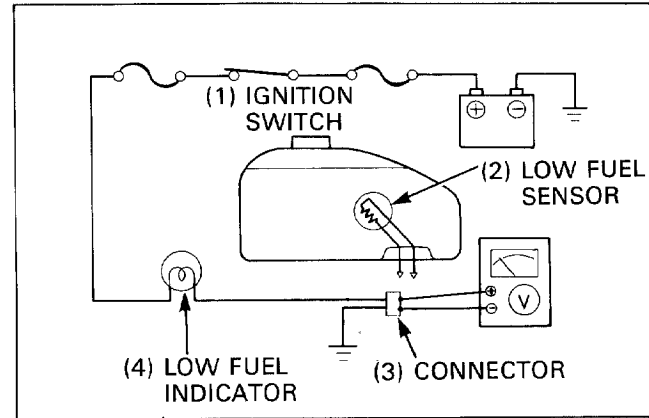

If the low fuel indicator does not turn on, check as noted below.

**NOTE**

- Make sure that the fuel level sensor is not submerged in the gasoline.

1. Check for battery voltage between the fuel level sensor connector terminals.

No battery voltage

Battery voltage

- Faulty fuel level sensor.
- Poor connection of the connector.

2. Check for battery voltage between the battery side of the wire from the indicator light and ground.

No battery voltage

Battery voltage

- Faulty sub fuse.
- Faulty ignition switch.
- Poor connection of the fuse holder connector.

- Blown bulb.
- Broken wire between the warning light and sensor.
- Faulty ground.

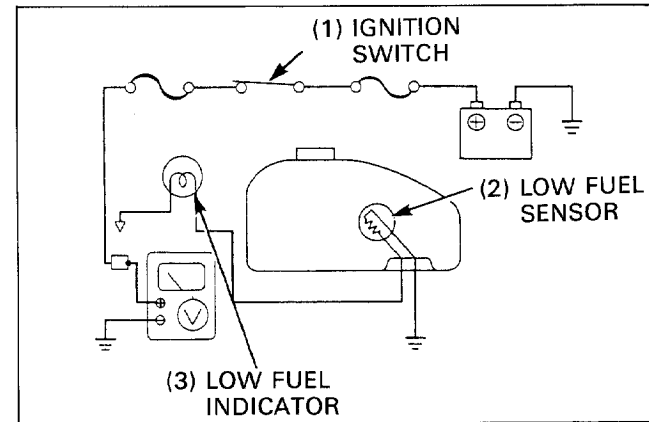

# Fuel Pump

## Fuel Pump Inspection

Remove the rear fairing (page 2-3).

Turn the ignition switch off.

Disconnect the fuel pump relay wire connector and temporarily connect the black and black/blue wire terminals at the main wire harness connector with a jumper wire.

Disconnect the fuel outlet tube at the fuel pump and connect a fuel tube or equivalent to the pump outlet line. Hold a graduated breaker under the pump outlet line.

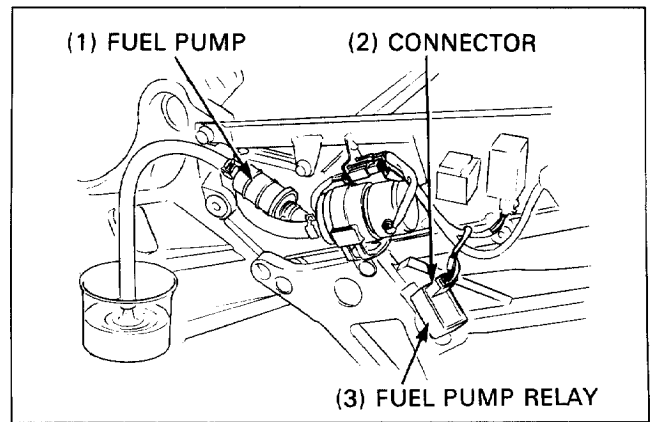

**▲ WARNING**

- Gasoline is extremely flammable and is explosive under certain conditions. Work in a well ventilated area. Do not smoke or allow flames or sparks in the your work area or where gasoline is stored.

Turn the ignition switch on and let fuel flow into the beaker for 5 seconds, then turn the ignition switch off. Multiply the amount in the beaker by 12 to determine the fuel pump flow capacity per minute.

### Fuel Pump Flow Capacity:

900cc (30.4 US oz. 31.7 Imp oz)min./minute

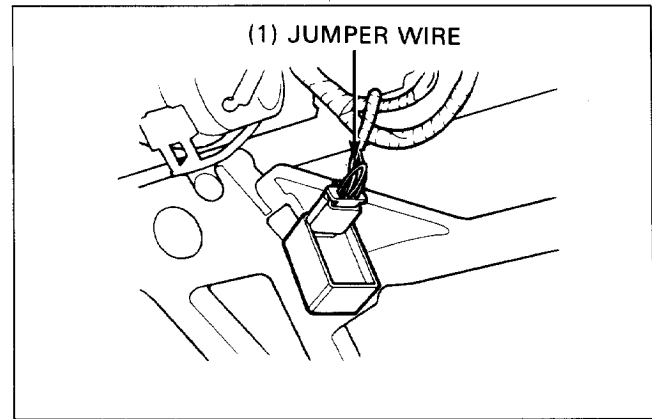

## Fuel Cut-off Relay Inspection

If the pump flow capacity is out of order, check the fuel pump relay circuit as below:

Disconnect the 3P mini connector and check it for loose contact or corroded terminals.

### Inspect as follows:

Measure the following resistances of the wire harness side.

Item	Standard
Between BI (+) and body ground (-) with the ignition switch "ON"	Battery voltage should come.
R/Y wire between the pump relay and spark unit	Continuity
BI/Bu wire between the pump relay and fuel pump	Continuity

# Coolant Temperature Gauge

Remove the middle fairing (page 2-4).

Disconnect the connector from thermosensor and short it.

Turn the ignition switch ON.

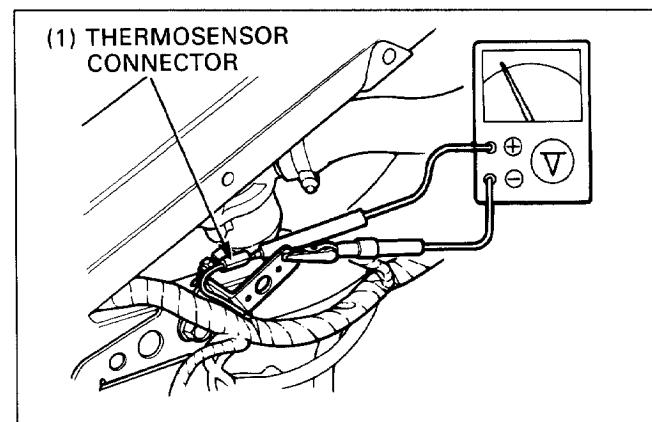

The temperature gauge needle should move all the way to H and battery voltage should register.

**CAUTION**

- Do not leave the thermosensor wire shorted for longer than a few seconds or the temperature gauge will be damaged.

If battery voltage registers, but the temperature gauge does not move, replace the thermosensor.

If the battery voltage does not register, check the connectors for a loose or blown fuse.

Short the thermosensor connectors again.

If battery voltage does not register, there is an open circuit in the wire.

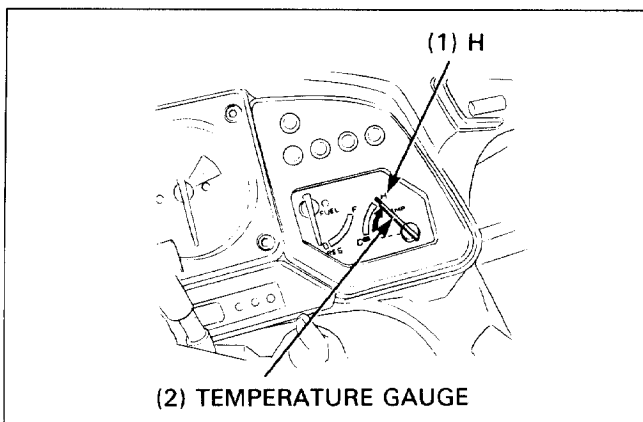

**Thermosensor**

Remove the middle fairing (page 2-4).

Disconnect the Green/Blue wire from the thermosensor. Check for continuity between the sensor body and ground. There should be continuity.

If there is no continuity, check the thermostat housing for looseness and recheck.

If there is still no continuity, drain the coolant (page 5-3) and remove the thermosensor from the thermostat housing.

Suspend the thermosensor in a pan of coolant over an electric heating element and measure the resistance through the sensor as the coolant heats up.

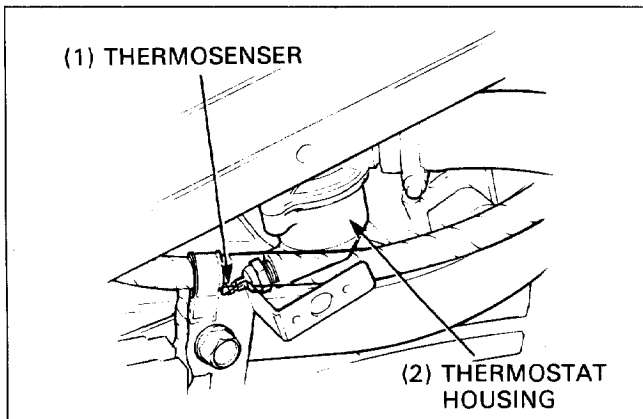

**WARNING**

- Wear insulated gloves and adequate eye protection.

Temperature	60°C (122°F)	100°C (212°F)
Resistance	90-120Ω	14-18Ω

**NOTE**

- Coolant must be used as the heated liquid to check the function above 100°C(212°F).
- You will get false readings if either the sensor or thermometer touches the pan.

Replace the sensor if it is out of specification by more than 10% at either temperature.

Refer to page 5-4 for thermosensor replacement.

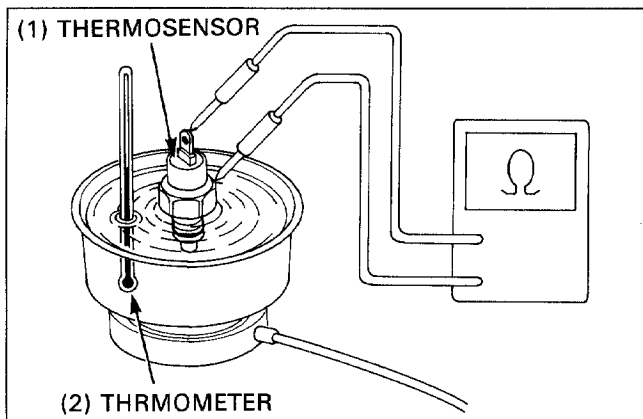

## Oil Pressure Switch

### NOTE

- To check the oil pressure, refer to Section 4 of the Common Service Manual.

Remove the middle fairing (page 2-4).

Disconnect the oil pressure switch wire from the switch by removing the terminal screw and short it.

Turn the ignition switch ON.

The oil pressure warning light should come on and battery voltage should be measured.

If the battery voltage is present, but oil pressure warning light does not come on, replace the oil pressure switch.

If the battery voltage is not measured and the oil pressure warning light does not come on, check the connectors for loose connection and check for a blown fuse or burnt out bulb.

Short the oil pressure switch wire again.

If the battery voltage is not measured, there is an open circuit in the wire.

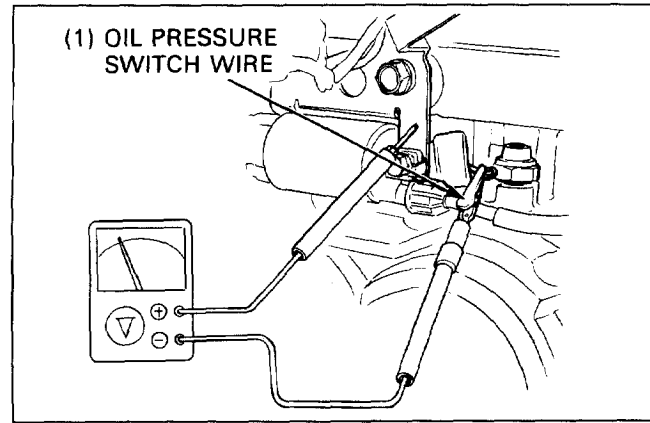

## Fan Motor Switch

Remove the middle fairing (page 2-4).

Disconnect the fan motor switch connector and short it.

Turn the ignition switch ON.

The fan motor should turn and battery voltage should be measured.

If the battery voltage is measured, but the fan motor does not turn, replace the fan motor.

If the fan motor does not turn and battery voltage does not register, check that battery voltage is measured between Black/Blue and Green terminal at the wire harness side on the 2P black connector.

If there is no battery voltage, check for a blown fuse, loose connector, or an open circuit in the wire.

If there is voltage, inspect the fan motor switch as follows: Remove the switch.

Connect one lead of an ohmmeter to the connector of the fan motor switch and the other to the body.

Suspend the fan motor switch in a pan of coolant (50-50 mixture) over an electric heating element and check the temperatures at which the switch opens and closes.

### ⚠ WARNING

- Wear insulated gloves and adequate eye protection.

Make sure that there is no continuity at room temperature and then gradually raise the coolant temperature. The switch should show continuity (closed) at 93°-97°C (199°-207°F).

### NOTE

- Keep the temperature constant for 3 minutes to confirm continuity. A sudden change of temperature will cause error temperature reading between the thermometer and switch.
- Do not let the switch or thermometer touch the pan as it will give a false reading.
- Immerse the switch in coolant up to its threads.

If the fan motor switch is good, check the Black/Blue, Black or Green wires for open circuit.

If there are no open circuit wires, replace the fan motor.

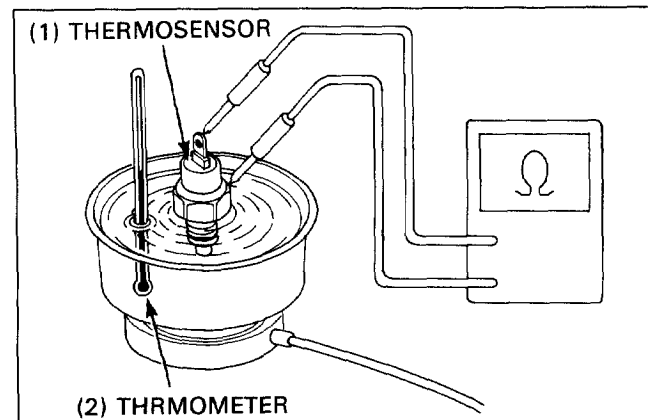
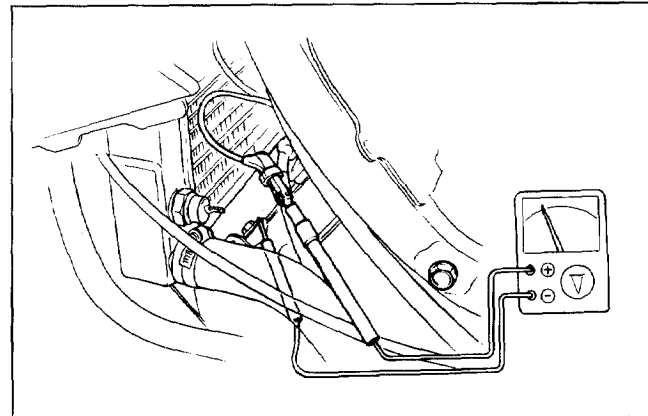

## Diode

'90-'93: Remove the middle fairing (page 2-4).  
 After '93: Remove the upper fairing (page 2-12).

Remove the diode and check for continuity with an ohmmeter.

**Normal Direction: Continuity**  
**Reverse Direction: No Continuity**

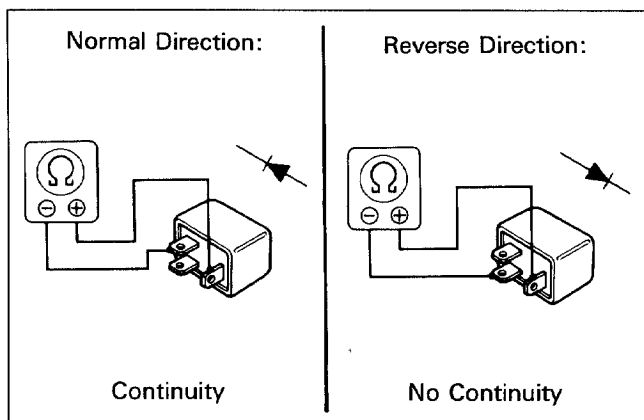
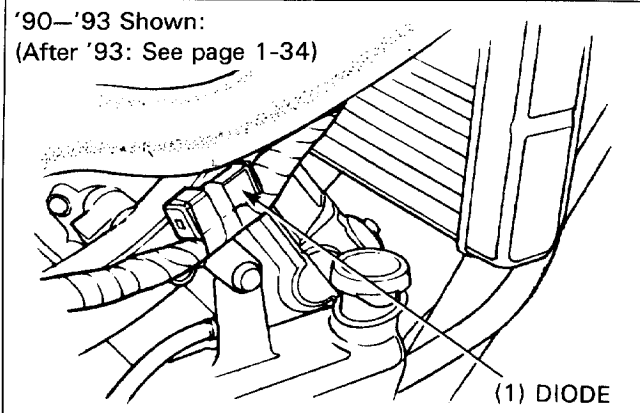

## Neutral Switch

Remove the lower fairing (page 2-7).

Check the neutral switch for continuity between the neutral switch terminal or ground.

There should be continuity when the transmission is in neutral and there should be no continuity with the transmission in any gear.

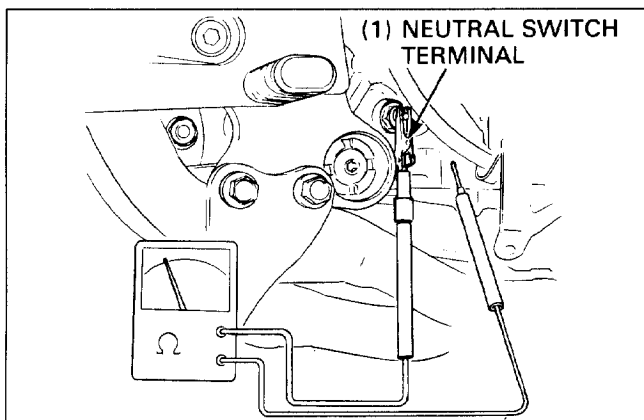

## Headlight Relay

Inspect the dimmer switch and lighting switch.  
 (Refer to Common Service Manual, section 25).  
 Remove the upper fairing (page 2-10).

**Headlight does not shut off:**  
 If the lighting switch is good, inspect the headlight relay.  
 If there is no problem in the headlight relay, check the wire harness for a short circuit.

**Headlight does not come on:**  
 Check for a burned out headlight bulb or a blown fuse.

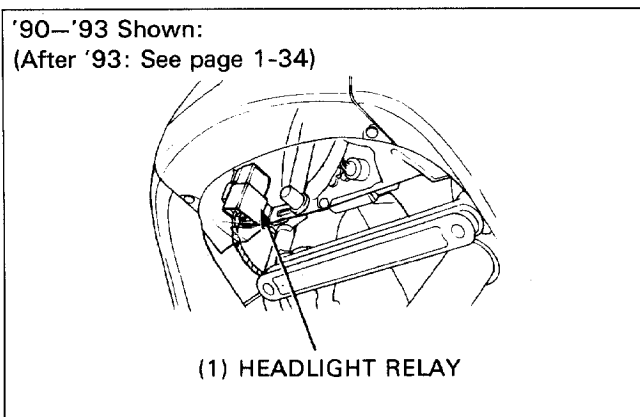

If there is no problem, remove the headlight relay and inspect as follows:

- Check the headlight relay for loose or corroded terminals.
- Check for continuity between the green wire and ground. If there is no continuity, the green wire is shorted.

If there is continuity, check for battery voltage between black/red and green on the 4P mini black connector.

If there is no battery voltage, there is an open circuit between the headlight relay and the fuse.

If there is battery voltage, inspect the headlight relay.

If there is no problem, there is open circuit between headlight relay and headlight, or headlight relay and lighting switch.

**Inspection**

Remove the headlight relay and headlight cover.

When applying battery voltage between blue and green terminals, there should be continuity between the black/red and blue/black wires.

If there is no continuity, replace the headlight relay.

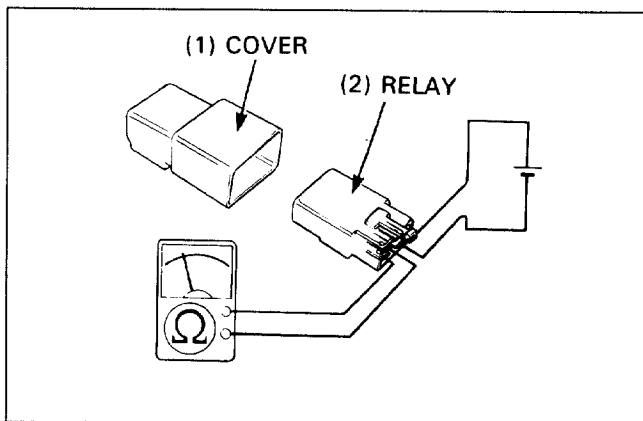
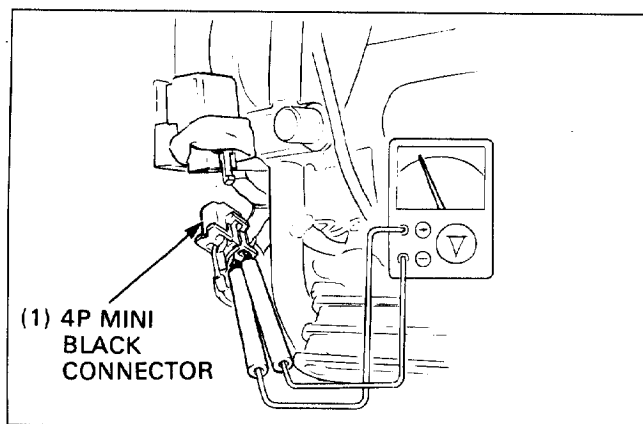

**High Beam Relay**

Remove the upper fairing (page 2-10).

When switching the high beam on, the high beam relay should click.

If the relay does not click, check the connector for a loose connection; check also for a blown fuse.

If there is no problem, check for battery voltage between the blue and green wires of the 4P mini connector.

If the battery voltage is measured, replace the high beam relay.

If the battery voltage is not measured, there is an open circuit in the blue wire.

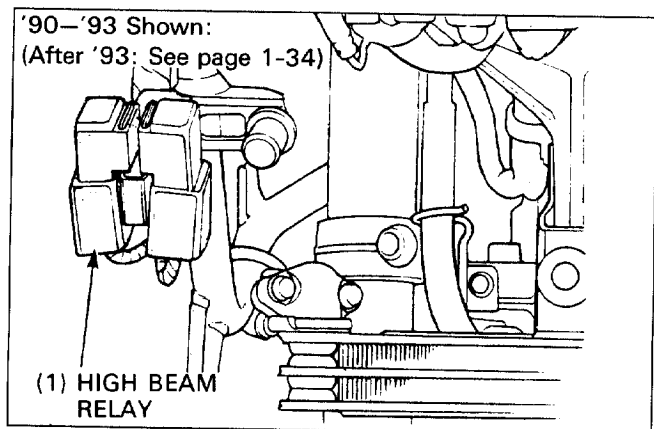



# 19. Wiring Diagram '90-'93:

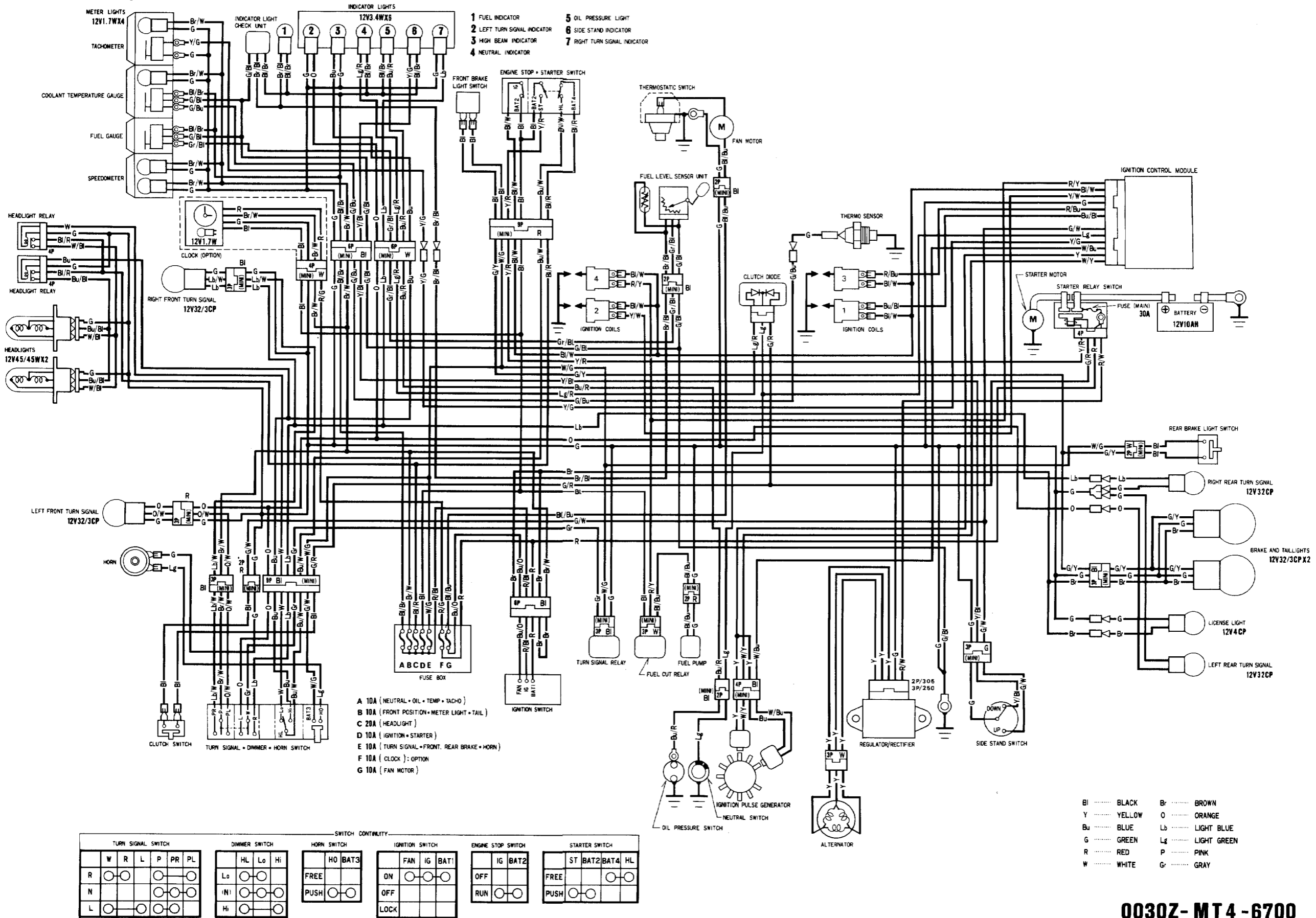

After '93:

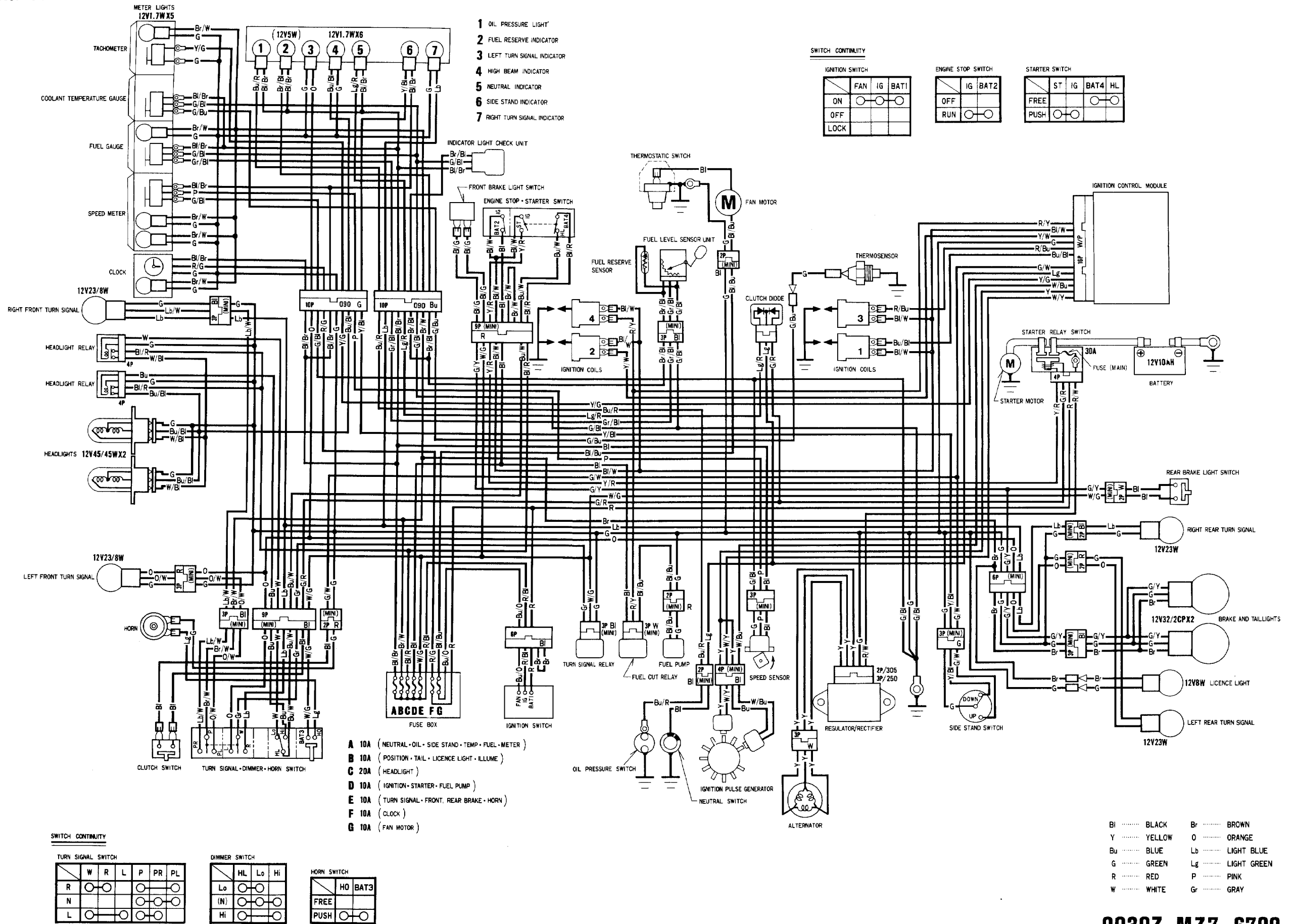

0030Z-MZ7-6700

# 20. Troubleshooting

<b>Engine Does Not Start or is Hard to Start</b>	<b>20-1</b>	<b>Poor Performance at High Speed</b>	<b>20-4</b>
<b>Engine Lacks Power</b>	<b>20-2</b>	<b>Poor Handling</b>	<b>20-4</b>
<b>Poor Performance at Low and Idle Speeds</b>	<b>20-3</b>		

## Engine Does Not Start or is Hard to Start

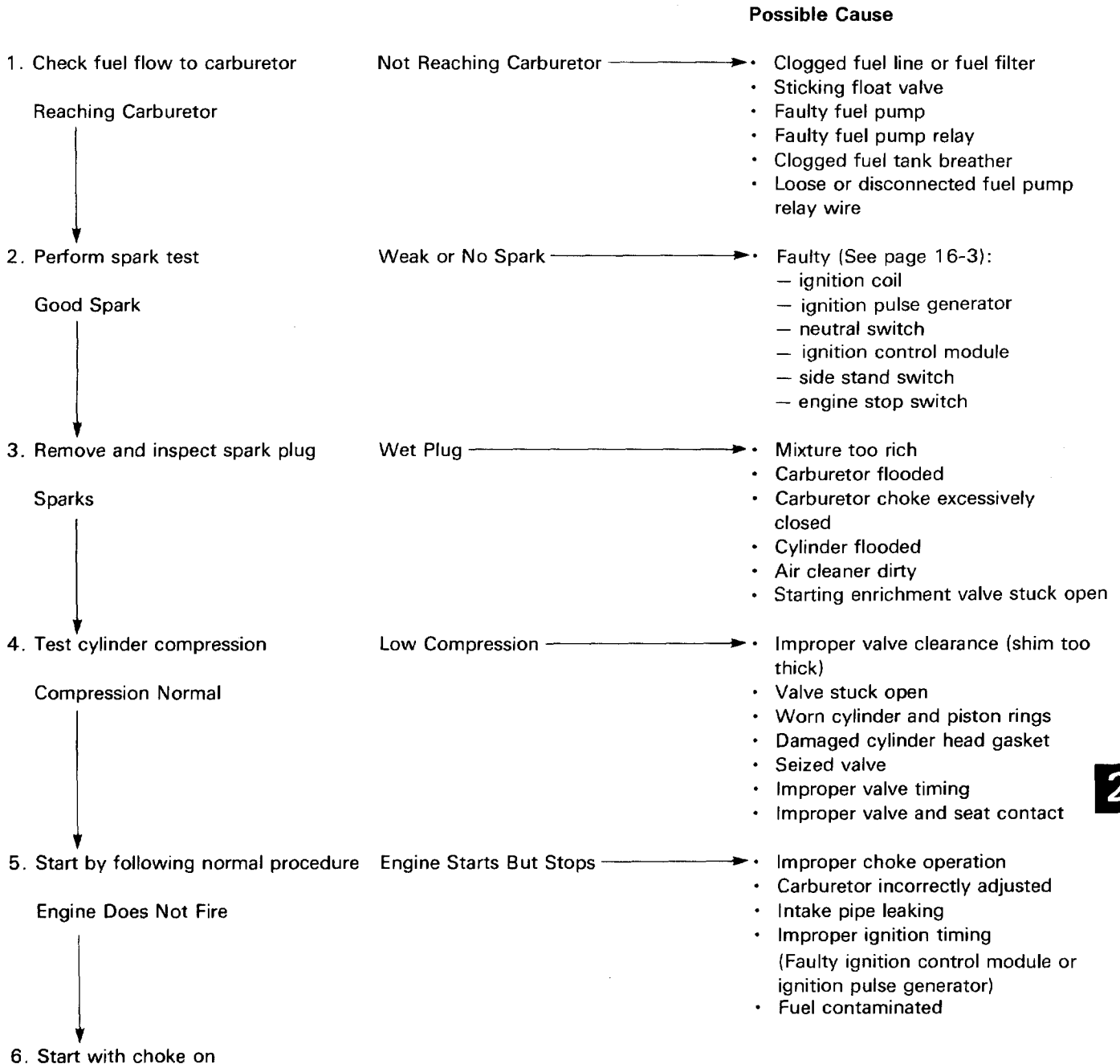

# Engine Lacks Power

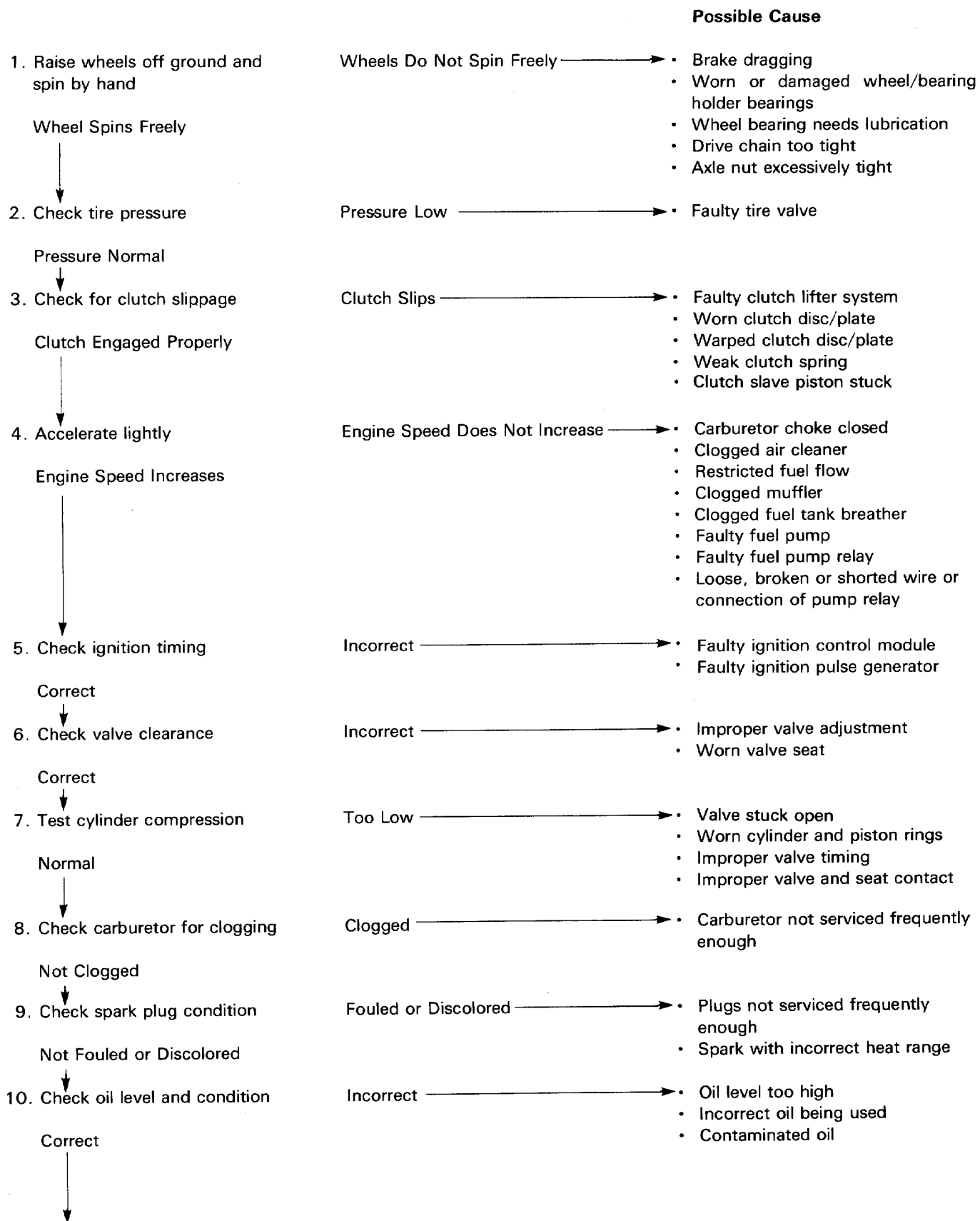

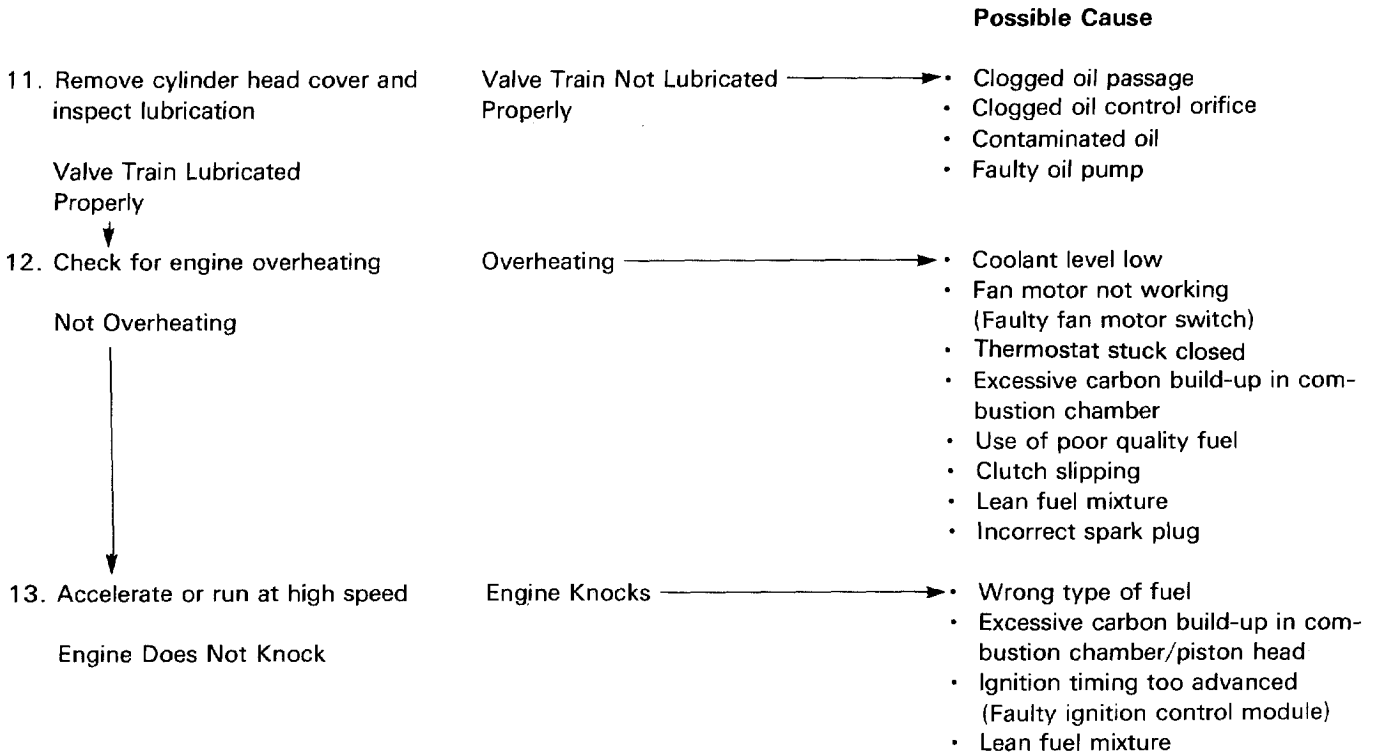

## Poor Performance at Low and Idle Speeds

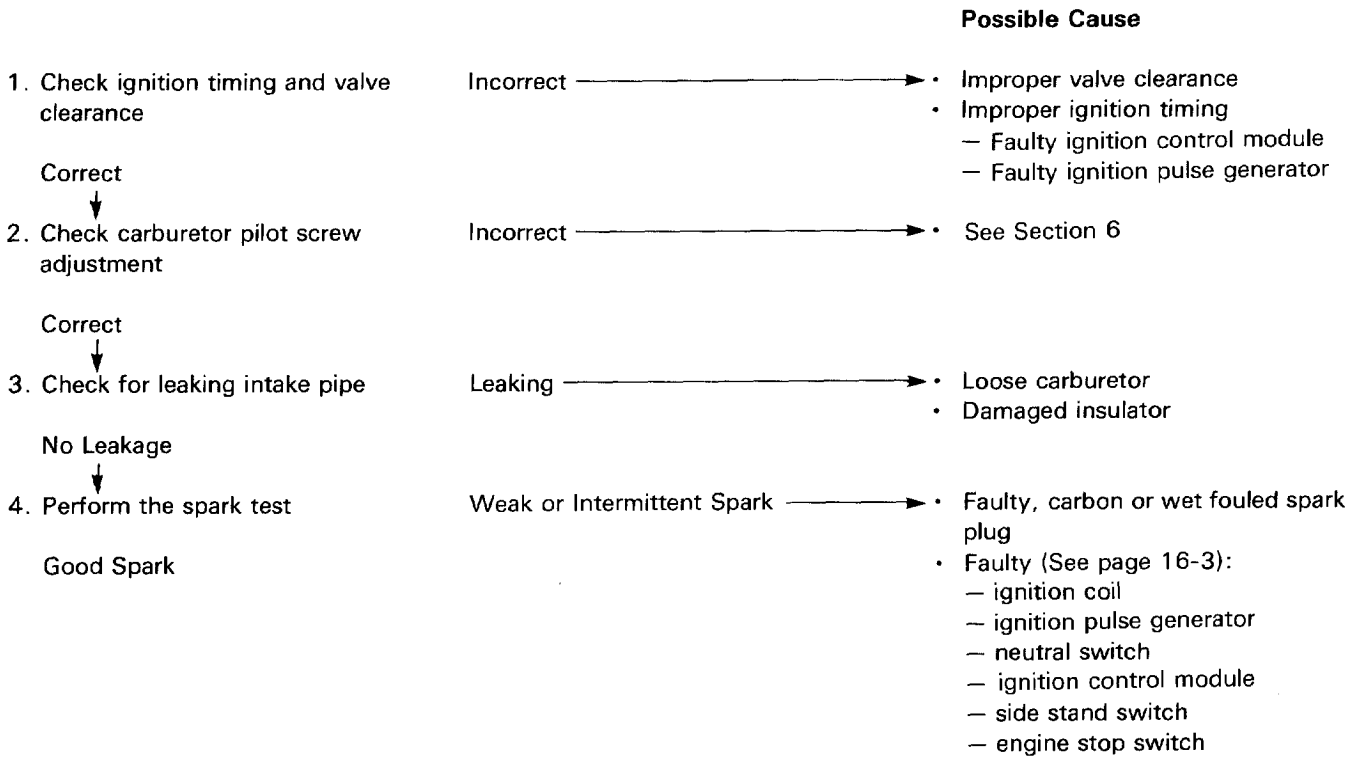

## Poor Performance at High Speed

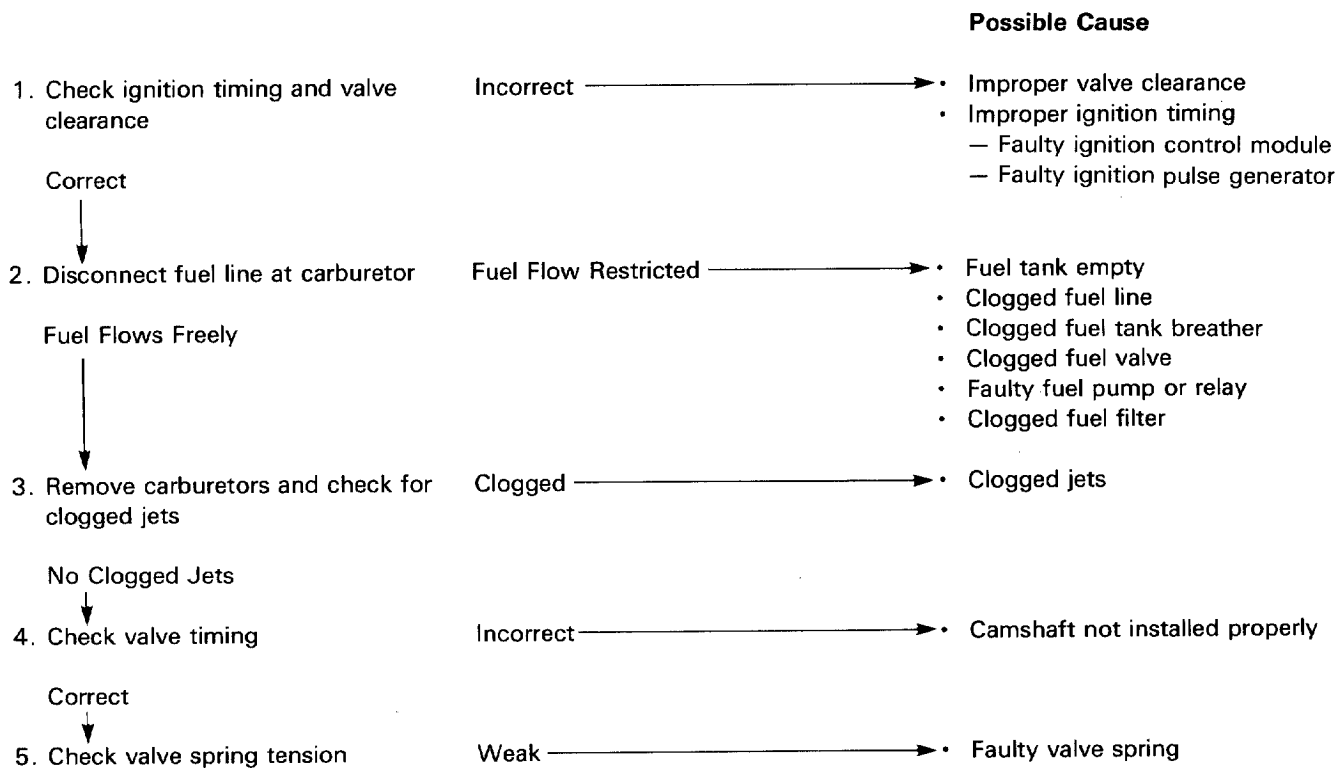

## Poor Handling

Check tire and suspension pressure

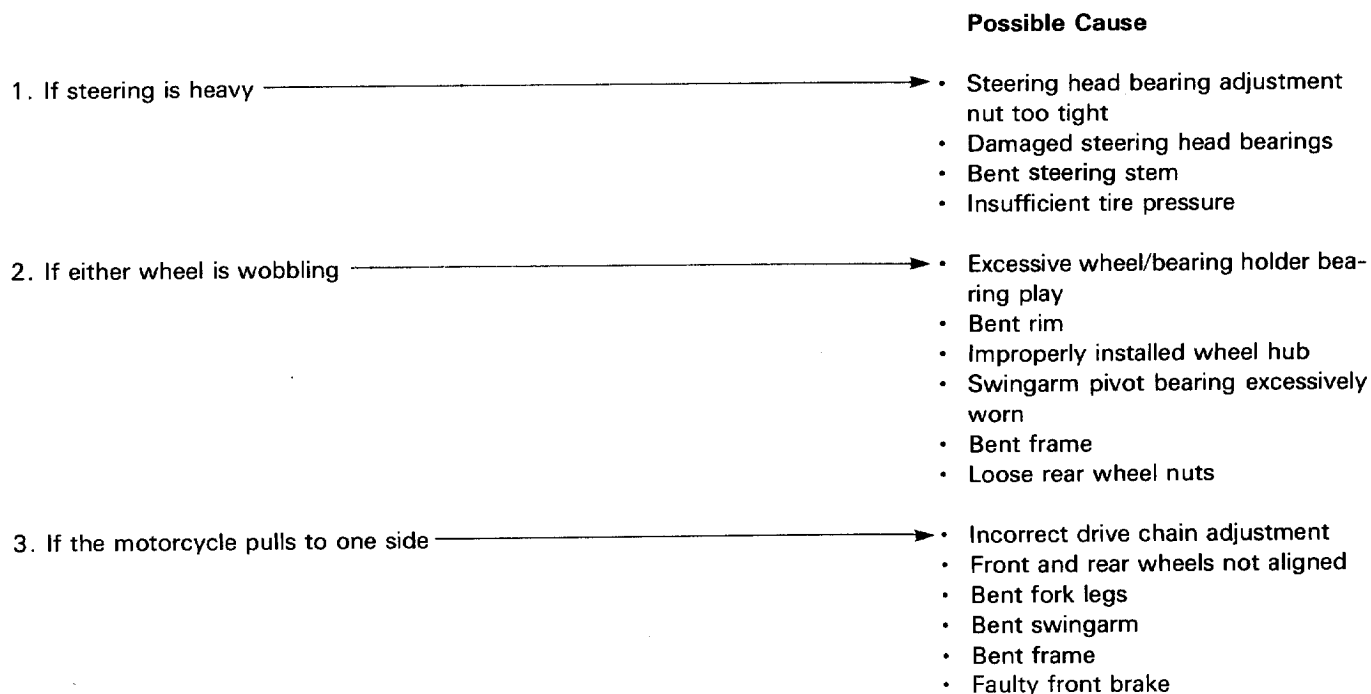

# 21. Index

Air cleaner .....	3-6	Gearshift Linkage Removal/Installation .....	10-4
Housing Removal/Installation .....	6-3	General Safety .....	1-1
Alternator Removal/Installation .....	15-7	Headlight .....	
Battery Removal/Installation .....	15-4	Aim .....	3-15
Bearing Holder Removal/Installation .....	13-3	Bulb Replacement .....	18-5
Brake Pedal Removal/Installation .....	14-12	Relay .....	18-20
Cable and Harness Routing .....	1-29	Removal/Installation .....	18-6
Camshaft Installation .....	8-8	High Altitude Adjustment (U.S.A. only).....	6-24
Removal .....	8-2	High Beam Relay .....	18-21
Carburetor Combination (After '93) .....	6-12	Ignition .....	
Disassembly/Assembly .....	6-16	Coil .....	16-6
Removal/Installation .....	6-4	Coil Removal/Installation (After '93) .....	16-8
Separation (After '93) .....	6-10	Pulse Generator .....	16-7
Separation/Combination('90-'93) .....	6-8	Pulse Generator Removal/Installation .....	16-10
Synchronization .....	3-11	Switch Removal/Installation.....	18-14
Charging Coil Inspection .....	15-8	System Inspection .....	16-6
Charging System Inspection .....	15-5	Timing .....	16-7
Circuit Diagram .....		Indicator Bulb Replacement.....	18-8
Charging System/Alternator .....	15-2	Left Handlebar Removal/Installation .....	12-3
Electric Starter/Starter Clutch .....	17-3	Lower Fairing .....	2-7
Ignition System .....	16-2	Center Fairing .....	2-8
Clutch Installation .....	9-4	Low Fuel Indicator .....	18-16
Master Cylinder Disassembly/Assembly .....	9-7	Lubrication and Seal Points.....	1-25
Removal .....	9-3	Lubrication System Diagram .....	4-2
Slave Cylinder Disassembly/Assembly .....	9-8	Mainshaft Disassembly/Assembly .....	11-12
Combination Meter Disassembly/Assembly .....	18-11	Maintenance Schedule .....	3-4
Removal/Installation .....	18-9	Middle Fairing .....	2-4
Coolant Draining .....	5-3	Model Identification .....	1-3
Temperature Gauge .....	18-17	Neutral Switch .....	18-20
Countershaft Disassembly/Assembly .....	11-14	Oil Cooler Removal/Installation .....	4-5
Crankcase Installation .....	11-16	Oil Pressure Switch .....	18-19
Separation .....	11-2	Oil Pump Disassembly/Assembly .....	4-4
Crankshaft Bearing Replacement .....	11-8	Removal/Installation .....	4-3
Crankshaft/Connecting Rod Removal/Installation .....	11-4	Pilot Screw Adjustment .....	6-22
Cylinder Head Disassembly/Assembly .....	8-6	Piston Disassembly/Assembly .....	11-6
Cylinder Head, Camshaft .....		Radiator Disassembly/Assembly .....	5-6
Idle Gear Case Removal/Installation .....	8-4	Removal/Installation .....	5-5
Diode .....	18-20	Rear Brake .....	
Drive Chain .....	3-12	Caliper Disassembly/Assembly .....	14-11
Drive Sprocket Cover Removal/Installation .....	10-2	Caliper Removal/Installation .....	14-10
Driven Flange, Bearing Holder .....		Pad Replacement .....	14-3
Disassembly/Assembly .....	13-4	Rear Faring .....	2-3
Emission Control .....		Rear Illumination/Taillight .....	18-5
Systems .....	1-42	Rear Master Cylinder Disassembly/Assembly .....	14-9
Emission Control Information Labels .....	1-44	Removal/Installation .....	14-8
Engine Mounting Bolt Installation .....	7-4	Rear Wheel Removal/Installation .....	13-2
Engine Removal/Installation .....	7-2	Regulator/Rectifier .....	15-6
Exhaust System .....	2-14	Right Crankcase Cover Removal/Installation.....	9-2
Fan Motor Switch .....	18-19	Right Handlebar Removal/Installation .....	12-2
Fork Assembly .....	12-14	Seat .....	2-2
Disassembly .....	12-10	Secondary Air Supply System (U.S.A. Only) .....	6-25
Removal/Installation .....	12-8	Service Access Guide .....	3-2
Front Brake .....		Service Information .....	
Caliper Disassembly/Assembly .....	14-7	Body Panels/Exhaust System/Sub Frame ...	2-1
Caliper Removal/Installation .....	14-6	Brakes .....	14-1
Pad Replacement .....	14-2	Charging System/Alternator .....	15-1
Front Master Cylinder Disassembly/Assembly .....	14-4	Clutch System .....	9-1
Front Wheel Disassembly/Assembly.....	12-6	Cooling System .....	5-1
Removal/Installation .....	12-4	Crankshaft/Piston/Transmission .....	11-1
Fuel Level Sensor/Fuel Gauge .....	18-15	Cylinder Head/Valve .....	8-1
Fuel Pump .....	18-17	Electric Starter/Starter Clutch .....	17-1
Fuel Tank .....	2-22	Engine Removal/Installation .....	7-1
Disassembly/Assembly .....	6-6	Front Wheel/Suspension/Steering .....	12-1

Service Information	
Fuel System .....	6-1
Gearshift Linkage .....	10-1
Ignition Coil.....	16-6
Ignition System Inspection.....	16-6
Lights/Meters/Switches .....	18-1
Lubrication System .....	4-1
Maintenance .....	3-1
Rear Wheel/Suspension .....	13-1
Shock Absorber Disassembly/Assembly	
('90-'93 Only) .....	13-10
Removal/Installation .....	13-6
Side Stand .....	3-15
Switch .....	18-15
Spark Plug .....	3-7
Specifications .....	1-5
Starter Clutch Disassembly/Assembly .....	
Removal/Installation .....	17-10
Starter Motor Disassembly/Assembly .....	17-8
Removal/Installation .....	17-7
Steering Stem Removal/Installation .....	12-18
Sub Frame/Rear Fender .....	2-18
Suspension Linkage Disassembly/Assembly .....	
Removal/Installation .....	13-14
Swingarm Disassembly/Assembly .....	
Removal/Installation .....	13-20
System Flow Pattern .....	5-2
System Location	
Charging System/Alternator .....	15-2
Electric Starter/Starter Clutch .....	17-2
Ignition System .....	16-2
Lights/Meters/Switches .....	18-2
Tachometer Inspection .....	18-14
Taillight .....	18-7
Thermostat Removal/Installation .....	5-4
Thermosensor .....	18-18
Tools .....	1-23
Torque Values .....	1-16
Transmission Removal/Installation .....	11-10
Troubleshooting	
Body Panels/Exhaust System/Sub Frame.....	
Brakes .....	14-1
Charging System/Alternator .....	15-3
Clutch System .....	9-1
Cooling System .....	5-1
Crankshaft/Piston/Transmission .....	11-1
Cylinder Head/Valve .....	8-1
Electric Starter/Starter Clutch .....	17-4
Engine Does Not Start or is Hard to Start ...	20-1
Engine Lacks Power.....	20-2
Front Wheel/Suspension/Steering .....	12-1
Fuel System .....	6-1
Gearshift Linkage .....	10-1
Ignition System .....	16-3
Lights/Meters/Switches .....	18-3
Lubrication System .....	4-1
Poor Handling .....	20-4
Poor Performance at High Speed.....	20-4
Poor Performance at Low and Idle Speeds ..	20-3
Rear Wheel/Suspension .....	13-1
Turn Signal Light .....	18-7
Upper Fairing .....	2-10
Valve clearance .....	3-7
Water Pump/Water Pipe Disassembly/Assembly ..	5-7
Wiring Diagram .....	19-1



**90-96**  
**VFR750F**

61MT406

HONDA MOTOR CO., LTD. TOKYO, JAPAN



MADE FROM 50% RECYCLED PAPER  
MINIMUM 10% POST-CONSUMER CONTENT

IPC©A20009509L-R  
PRINTED IN U.S.A.

# Other ManualsLib Projects



[www.manualslib.com](http://www.manualslib.com)



[www.manualslib.de](http://www.manualslib.de)



[www.manualslib.es](http://www.manualslib.es)



[www.manualslib.fr](http://www.manualslib.fr)



[www.manualslib.nl](http://www.manualslib.nl)



[www.manualslib.mx](http://www.manualslib.mx)



[www.manualslib.tech](http://www.manualslib.tech) 30+ Languages